

Metallographic preparation of microelectronics

Over the past 25 years, the development and production technology of electronic equipment has seen a continuous, rapid advance. Previously, electronic equipment and consumer goods were large and bulky and contained components individually wired on large printed circuit boards. Today, portability of electronic devices is behind the drive for miniaturization, and as computers, cell phones and cameras are shrinking in size, they accommodate a multitude of functions. The miniaturization of components has been made possible by the development of microelectronics, which contain as their central part integrated circuits (IC). ICs have drastically reduced the need for individual electronic components (resistors, capacitors, transistors, etc) as building blocks in electronic circuits. The advantages of ICs over wired circuits are a significant reduction of size and weight, increase in reliability, lower cost and improvement of circuit performance.

An integrated circuit is a device that combines (integrates) active components, for instance transistors, diodes etc, and passive compo-

nents, such as resistors and capacitors, of a complete electronic circuit in a single tiny slice of semi-conductive material, usually silicon (Fig. 1 and 2). This device is called a chip. Chips incorporate the functions of multitudes of transistors, capacitors and other electronic elements, all interconnected to perform the task of a complex circuit. The design and manufacturing of interconnecting chips is called packaging (see below). These chip-based components are mounted on a printed circuit board which plugs into an electronic unit (Fig. 3).

The components are mass-produced and therefore the quality control is usually limited to a thermal cycling test to detect faulty parts. However the development, design and failure analysis of chip-based components require metallographic cross sections of the components to look at microvias, cracks, and voids, solder balls, conducting layers, connections etc. Also, metallography is used for spot checks of production at different stages. As these components are very small, special preparation techniques and equipment are required to ensure the precision needed for preparing and observing these metallographic samples.

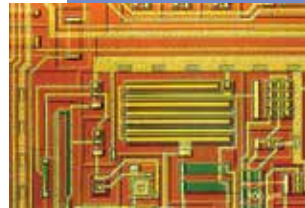
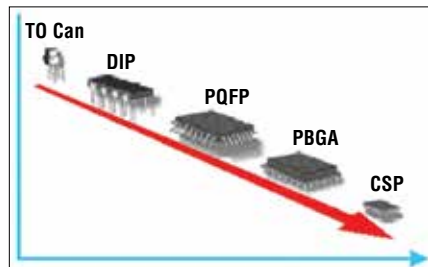

Fig. 1: Detail of a linear integrated circuit with conducting leads, transistors, resistors, vias and capacitors in the center



Fig. 2: Cross section of a silicon wafer with conducting leads of IC



IC packaging evolution. Courtesy: Tessera

Difficulties during metallographic preparation

The main difficulties of preparing microelectronics for metallographic inspection are the small sample geometries. Tiny and complex, ICs offer the greatest challenges regarding preparation. The 3-dimensional aspect needs to be taken into account during the preparation process, and it requires time, precision and patience to achieve a representative result. Following are some of the common difficulties occurring during preparation:

Cutting: Chipping and cracking of wafers, glass, ceramics

Mounting: Mechanical deformation and thermal damage

Grinding: Fracture of brittle constituents such as glass fibers or ceramics (Fig. 4).

Polishing: Smearing of soft metal layers. Relief due to hardness differences of materials in a component (Fig. 5). Silicon carbide and diamond particles remaining in solder (Fig 6).



Fig. 4: Crack and fracture damage in glass diode caused by coarse grinding SiC Foil/Paper

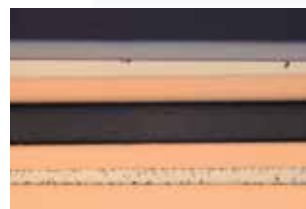

Fig. 5: Relief from polishing due to different hardness of materials



Fig. 6: Diamond particles in solder

Solutions:

Use of special tools and automatic equipment to cut, grind and polish to the target quickly.

Use cold mounting.

Fine grinding and polishing with diamond on rigid discs and hard polishing cloths.



Fig. 3: Components mounted on printed circuit board

Production process and application of microelectronics

The production of chip-based components is a very complex process, involving various specialized manufacturers whose involvement from conception of a new component to the final product is overlapping. In the following the basic production steps of a chip-based component are briefly described:

Design

If a manufacturer of electronic equipment decides to make a new product, it will need microelectronic components, which deliver the required functions and features of the equipment. Manufacturing a new component includes the chip design, part of which is the selection of the packaging design. The manufacturer can either design the component in-house, or out source it to dedicated design houses or chip manufacturers.

Prototyping

Usually a large number of prototypes are manufactured and tested to check that the new component has the desired properties. At this stage metallography plays an important role, because a large number of cross sections have to be processed and evaluated metallographically. These metallographic investigations can be carried out by the device manufacturer, the chip manufacturer and/or the packaging houses.

Chip production

Based on the chip design, manufacturing is carried out by chip foundries or "fabs". The base material for chips is a wafer cut from a single crystal (usually silicon).

Packaging

The chips must be interconnected and assembled to become functional. The design and manufacturing of these interconnections is called packaging. The interconnections with wires, solder balls, conducting layers are all covered with plastic or ceramic at the end of the manufacturing process. The wafers are cut up into individual dice and packaged in different ways (Fig. 7). There are two main interconnecting technologies: wire bonding and ball grid array (BGA). For extreme compactness flip-chip technology may be applied, which is a direct interconnection between chip and PCB.

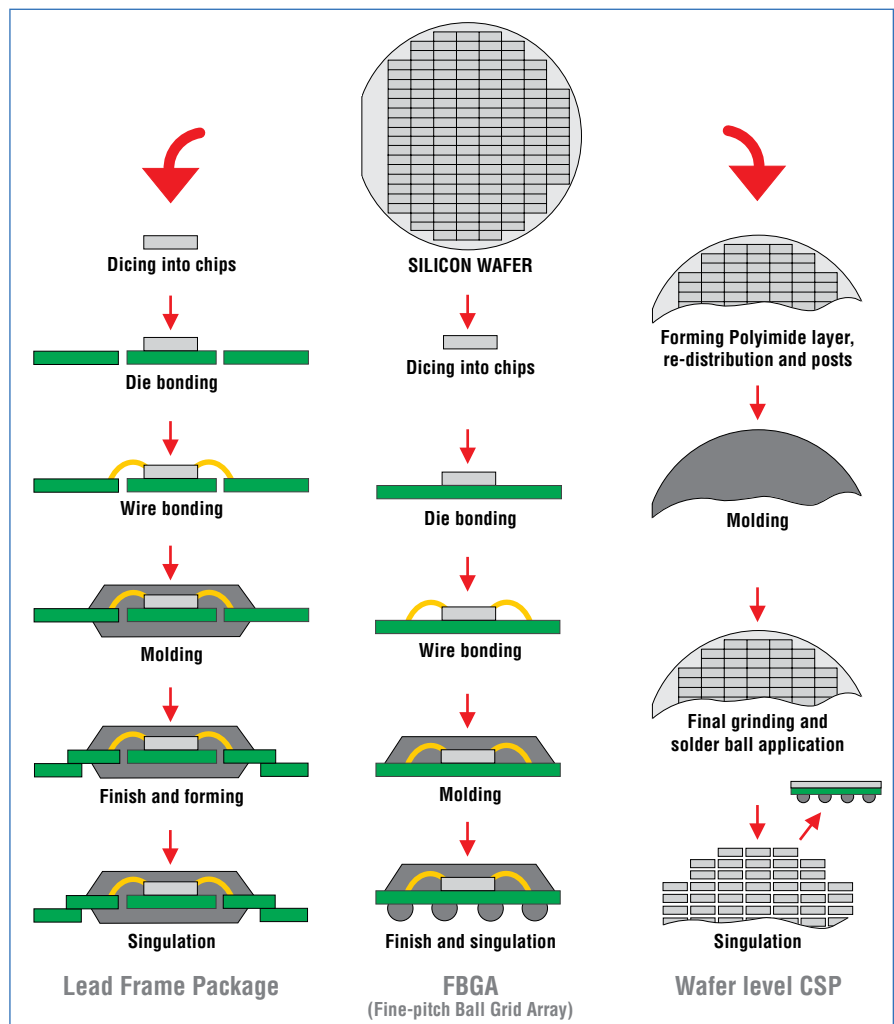

Fig. 7: Different chip packaging methods

Testing

At this stage of the manufacturing process the mass quality control with thermal cycling takes place. This is a final test to sort out faulty components.

Application

Microelectronics are applied in a wide range of products, such as communication, data processing and consumer goods. For instance, a car may contain as many as 150 computers. However, microelectronics are increasingly used in non traditional application areas, and new applications are added continuously including automatic scanning of groceries in supermarkets using ultra thin flexible chips on each product.

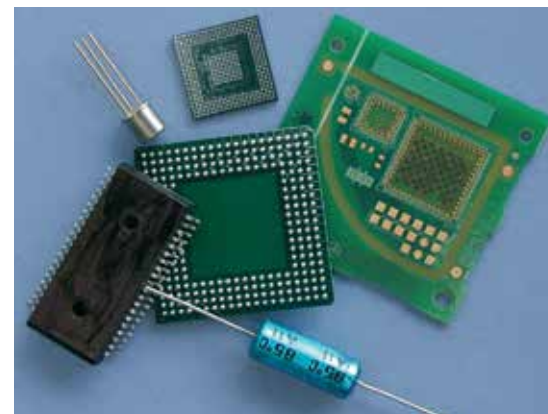

Various microelectronic components



New applications are added continuously including automatic scanning of groceries in supermarkets using ultra thin flexible chips on each product

Difficulties in the preparation of microelectronics

One of the main requirements of the metallographic inspection in a given sample is to look at a particular area inside a package. The manual technique of “grind-and-look” until the target appears and is ready to be polished, is very time consuming. In research or failure analysis, missing the target often means losing a unique and/or costly sample.

In microelectronic components various materials with widely differing properties are packaged together: glass, ceramics, metals and polymers (Fig. 8). The various combinations of these materials require a preparation that will reveal the individual characteristics of these materials, but does not introduce any artefacts such as smearing of metal and polymers, or damage of glass or ceramic. This is particularly important as the investigation of microelectronics includes various types of evaluations in which artefacts introduced by the preparation can lead to faulty conclusions. Some of the following checks are carried out:

- Size and distribution of defects such as voids, inclusions and cracks (Fig. 9).
- Bonding and adhesion of materials and their interfaces.
- Dimensions and shape of the different parts in the package: layer thickness, wires, solder meniscus.
- Porosity and cracks in ceramics.
- Flatness and edge retention is specifically important as often very thin layers between the various materials have to be inspected at high magnifications (Fig.10 a and b).

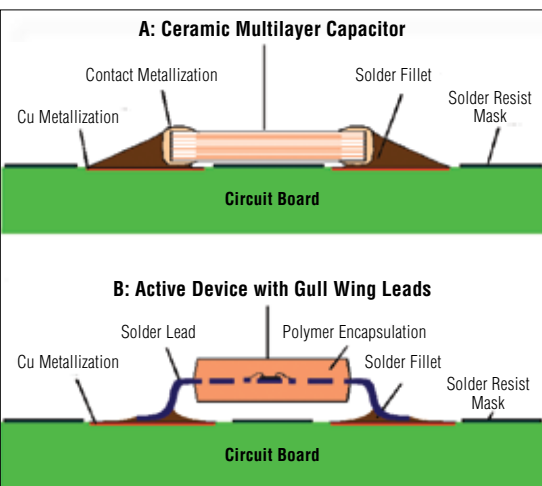

Fig. 8: Example of material compositions in microelectronic components

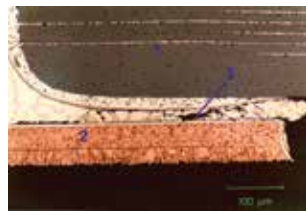

Fig. 9: Multilayer capacitor (1) soldered onto a copper metallization of the circuit board (2). Fatigue crack (3) continuously propagating through solder



10 a



10 b

Fig. 10 a and b: Ceramic with copper at high magnification showing difference in flatness: a) initial fine grinding with silicon carbide Foil/Paper b) initial fine grinding with diamond on MD-Largo fine grinding disc

Recommendations

The majority of metallographic investigations of microelectronics are carried out on cross-sections, and the mentioned procedures are for cross-sections. However, some special investigations may require parallel sections, for which most of the recommendations are also valid.

As mentioned above, one of the main goals of a cross-section of a microelectronic component is to reveal a specific target area in component. Great care should be taken when removing material during cutting and grinding processes. For both, several techniques are available, and some manual, semi-automatic and automatic procedures are described below. The degree of automation increases the success rate of hitting the target.

Cutting: Depending on what kind of sample needs to be investigated the cutting can be done on various precision cut-off machines. For instance a mobile phone, or a board mounted with components, can easily be cross sectioned on a medium-sized machine, on which the operator pushes the device through the cut-off wheel manually as on Secotom-1. An electroplated diamond wheel for cutting plastics (E1D20) or a resin bonded diamond wheel (BOD20) is recommended. If the components to be cut are larger Secotom-15/-50 can be used (here same type of cut-off wheel are used, but size can be either 20 mm dia. or 15 mm dia. for finer cut. For sectioning individual, small or fragile components, the Accutom-10/-100 is recommended (smaller cut-off wheels can be used).



Secotom-1



Accutom-10/-100

Depending on the size or fragility of a component or assembly, mounting prior to cutting may be necessary for holding parts or components together to avoid mechanical damage.

In any case, the cut should be placed far enough from the actual area that is to be observed, to avoid possible direct damage to it. Remaining material can then be carefully ground away after sectioning. The more careful this initial step is carried out, the less likely it can introduce cracks in ceramic, chips and glass, or cause delamination of layers or solder spots.

Mounting: Due to their composite and fragile nature, microelectronic components are not suited for hot compression mounting, and are therefore always cold mounted. Cold mounting resins, which develop high curing temperatures, are not recommended, as the heat can influence solder and polymers, and the high shrinkage of resins can crack silicon wafers.

Mounting methods differ depending on the analytical method used. For regular mounts for the optical microscope transparent epoxy resins are used (ProntoFix, EpoFix, Specifix-20). If voids and holes have to be filled, vacuum impregnation is recommended. Mixing a fluorescent dye (EpoDye) with the epoxy gives an excellent contrast of voids and cracks when using a long pass blue and a short pass orange filter in the optical microscope. For very small vias a transparent resin with a low viscosity that flows easily into the holes is recommended.

When using the Struers TargetSystem, components may be mounted directly in the special sample support used for target preparation (see right).

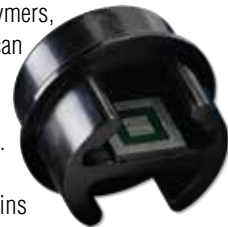

Table 1
Preparation Method
for microelectronic components,
mounted, 30 mm dia.

Grinding and polishing

Depending on the size of the component and number of samples to be prepared either manual, semi-automatic or fully automatic grinding and polishing methods can be used, both for parallel and cross-sections. As a rule, plane grinding with coarse abrasives should be avoided as it can damage the brittle materials and introduce severe deformation in the soft metals (see Fig 4). For excellent flatness, fine grinding with diamond on a rigid disc (MD-Largo) is recommended, instead of grinding on silicon carbide Foil/Paper. Subsequent diamond polishing on a silk cloth retains the flatness very well. In case of embedded abrasive particles in soft metal, the diamond polish needs to be extended until the particles are removed. The final polish with colloidal silica (OP-U NonDry) should be brief to avoid relief.

Manual and semi-automatic target preparation

For manual preparation of non-encapsulated wafers and packages, Tripod is a helpful tool using the manual "grind-and-look" method. For this method, abrasive films, with grain sizes ranging from 30 μm to 0.05 μm , are mounted on a glass plate, and the specimen is manually ground and polished.

For manual and semi-automatic controlled material removal and target preparation with silicon carbide Foil/Paper, AccuStop and AccuStop-T are special sample holders for mounted and unmounted microelectronic components.

AccuStop-T has a tilt feature to allow alignment of targets, for instance a row of solder balls, so that they can all be ground to the same plane at once.

Tripod



AccuStop in
sample holder
plate

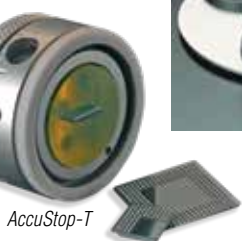

Grinding

After manual or semi-automatic grinding with AccuStop close to the target on silicon carbide foil/paper #320, #500 and #1000, the samples are inserted in an automatic machine for fine grinding and polishing with diamond.

Step		FG		
	Surface	MD-Largo		
	Abrasive	Type	Diamond	
		Size	9 μm	
	Suspension/ Lubricant	DiaPro Allegro/Largo 9		
	rpm	150		
	Force [N]/ specimen	30		
	Time (min)	4		

Polishing

Step		DP 1	DP 2	OP*
	Surface	MD-Dac	MD-Nap	MD-Chem
	Abrasive	Type	Diamond	Silica
		Size	3 μm	1 μm 0.04 μm
	Suspension/ Lubricant	DiaPro Dac 3	DiaPro Nap R 1	OP-U NonDry / OP-S Nondry
	rpm	150	150	150
	Force [N]/ specimen	20	20	15
	Time (min)	3	1	0.5

* Optional step

Once several specimens have been ground manually, or semi-automatically with AccuStop to approximately 50 μm before the target, the specimens are removed from AccuStop and transferred to a semi-automatic machine for fine grinding and polishing as individual samples. Table 1 shows a preparation method for semi-automatic fine grinding and polishing on Tegramin for individual samples.



TargetSystem







Automatic target preparation

For automatically controlled material removal and preparation the Struers TargetSystem offers alignment and measurement of the sample prior to the preparation. Cross and parallel sections of mounted and unmounted samples can be ground and polished to visible and hidden targets. A laser measurement system assures an accuracy of $\pm 5 \mu\text{m}$ and the removal rate is automatically recalculated during the preparation process.











Fig.11: Target-Z video for positioning and measuring visible targets

Grinding

Step		PG 	FG 	
	Surface	Diamond Pad	MD-Largo	
	Abrasive	Type	Diamond	Diamond
		Size	20 µm	9 µm
	Suspension/ Lubricant	Water	DiaPro Allegro/Largo 9	
	rpm	300	150	
	Force [N]/ specimen	35	40	
	Removal (µm) Time (min)	As calculated by system	20 µm	

Polishing

Step		DP 1 	DP 2 	OP* 
	Surface	MD-Dac	MD-Nap	MD-Chem
	Abrasive	Type	Diamond	Diamond
		Size	3 µm	1 µm
	Suspension/ Lubricant	DiaPro Dac 3	DiaPro Nap R 1	OP-U NonDry / OP-S Nondry
	rpm	150	150	150
	Force [N]/ specimen	25	20	10
	Removal (µm) Time (min)	15 µm	1	0.5

* Optional step

Alignment and measuring can either be video based for samples with a visible target (Fig. 11 and 13), or X-ray based for samples with a hidden target (Fig.12). TargetSystem then precalculates the amount of material to be removed, and automatically stops the plane grinding step approx. 35 µm before the final target plane.

The fine grinding step takes the sample down to approximately 15 µm before the target, and two polishing steps remove the remaining material to the pre-defined target plane of the specimen (Fig.14). The total preparation process, including cutting, takes 45-60 minutes.

Table 2 shows the data for automatic target preparation of a microelectronic component.

Table 2:
Preparation Method for target
preparation for a microelectronic
component

Etching

The differences in light, reflected from the various materials in a component, usually provide enough contrast rendering etching unnecessary. Final polishing with colloidal silica gives a slight attack of solder and copper, particularly if the final polishing step is carried out with OP-S NonDry suspension instead of the less aggressive OP-U NonDry suspension.

Adding a small amount of hydrogen peroxide (3%) to the OP-S NonDry suspension will enhance this attack sufficiently enough to see the structure. Overetching can occur very quickly if the OP-S NonDry polishing step takes longer than 30 seconds. It is recommended to check the sample after 30 seconds and extend the polish gradually as needed.

Etchant for copper and copper alloys:
25 ml water
25 ml ammonium hydroxide
0.5 -10 ml hydrogen peroxide (3%)

Using different illumination techniques can also enhance the contrast of the structure. Dark field is helpful for finding cracks in ceramics; differential interference contrast and polarized light also increase the contrast or colour of specific material structures and can contribute to a better structure interpretation.

Examples of typical microstructures in microelectronic components

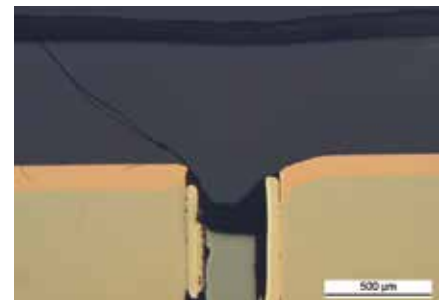

Detection of crack in a diode

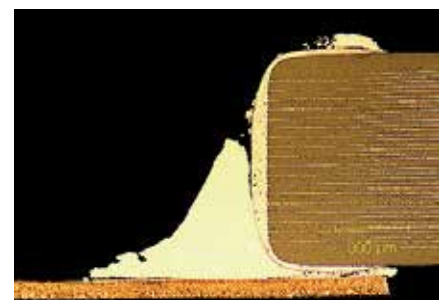

Section through an aged ceramic multilayer capacitor with fatigue cracks in the solder connection

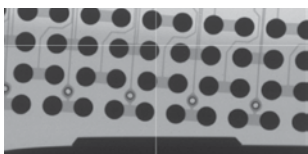

Fig. 12: X-ray of sample with hidden targets

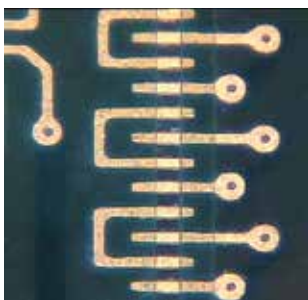

Fig. 13: Sample with visible target, shown using video

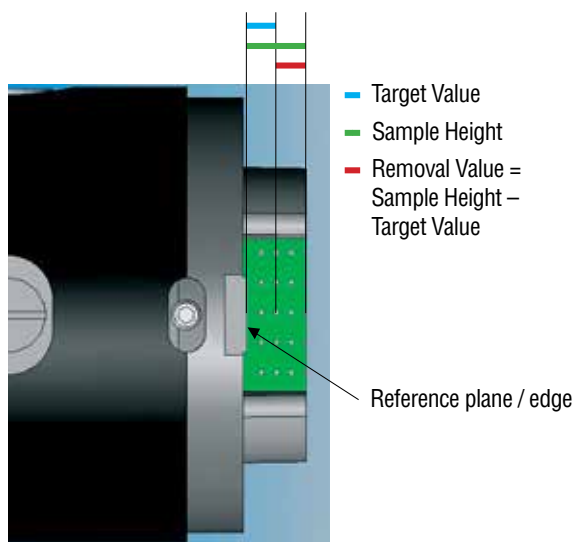
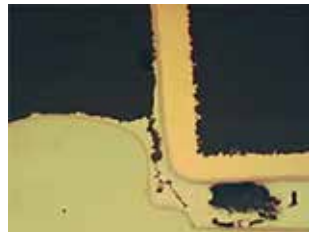
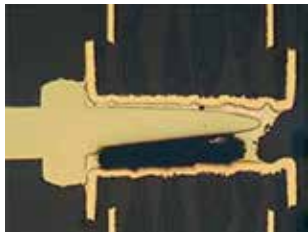
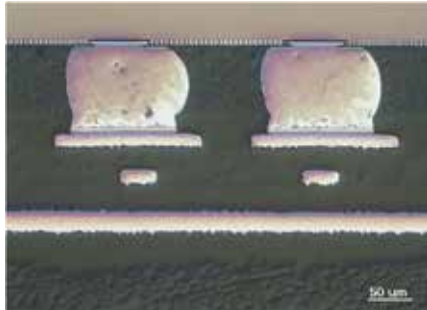

Fig. 14: Holder with sample indicating distances which are automatically measured and calculated



Large void in solder of a plated-through hole connection. 50 x

Void and crack in solder connection of a plated through hole. 200 x



Cross-section of solder balls, DIC.

Summary

The miniaturization of electronic devices has been made possible by the development of integrated circuits, which have reduced the need for individual electronic components as building blocks of electronic circuits. Metallography plays a vital role in the design, development and failure analysis of chip-based components. The metallographic preparation of cross sections of these microelectronics is very time-consuming, and requires patience and skill to grind and polish to a specific target inside the component. In addition, the different materials used in devices and components, such as metal, glass and ceramics, have different characteristics and make the preparation difficult. Special tools can help to improve the manual and semi-automatic preparation of microelectronics. For automatic target preparation the Struers TargetSystem offers a fast and very precise grinding and polishing to the target quickly. To avoid relief between hard and soft layers and materials, diamond grinding on rigid discs and diamond polishing on hard cloths is recommended.

Glossary

BGA:	Ball Grid Array
CSP:	Chip Scale Package
DIP:	Dual In-line Package
FBGA:	Fine-Pitch Ball Grid Array
IC:	Integrated Circuit
PBGA:	Plastic Ball Grid Array
PCB:	Printed Circuit Board
PQFP:	Plastic Quad Flat Package
TO Can:	Transistor Outline Canister

Application Notes

Metallographic preparation of microelectronics
Elisabeth Weidmann, Anne Guesnier, Hans Bundgaard, Struers A/S, Copenhagen, Denmark

Acknowledgements

Figs 1, 8, 9 courtesy F. W. Wulff, T. Ahrens, Fraunhofer-Institut für Siliziumtechnologie, Quality and Reliability, D-25524, Itzehoe, Germany

Figs 4, 5, 6, 10 a+b courtesy Katja Reiter, Mario Reiter, Thomas Ahrens, Institute für Siliziumtechnologie, Modulintegration, D-25524, Itzehoe, Germany

Bibliography

Structure 32, 1998, Microstructure and material analysis for electronic packaging, F. W. Wulff, T. Ahrens, Fraunhofer-Institut für Siliziumtechnologie, Quality and Reliability, D-25524, Itzehoe, Germany

Structure 34, Special aspects of metallographic preparation of electronic and microelectronic devices, Katja Reiter, Mario Reiter, Thomas Ahrens, Institute für Siliziumtechnologie, Modulintegration, D-25524, Itzehoe, Germany

Struers Structure 28, 1995, Accurate, metallographic preparation of blind, buried and filled holes in printed circuit boards.

Struers Structure 13, 1986, Anschliffe an elektronischen Bauteilen und Komponenten.

For further details on the mentioned Struers equipment, accessories and consumables please see www.struers.com or contact your local Struers representative.

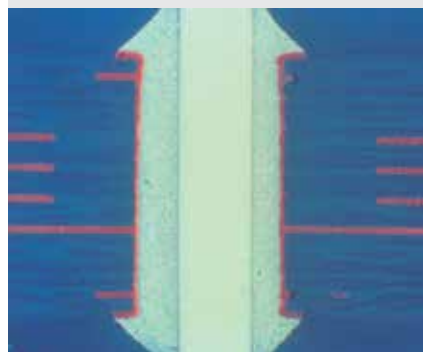

Struers ApS

Pederstrupvej 84
DK-2750 Ballerup, Denmark
Phone +45 44 600 800
Fax +45 44 600 801
struers@struers.dk
www.struers.com

AUSTRALIAN & NEW ZEALAND

Struers Australia
27 Mayneview Street
Milton QLD 4064
Australia
Phone +61 7 3512 9600
Fax +61 7 3369 8200
info.au@struers.dk

BELGIUM (Wallonie)

Struers S.A.S.
370, rue du Marché Rollay
F- 94507 Champigny
sur Marne Cedex
Téléphone +33 1 5509 1430
Télécopie +33 1 5509 1449
struers@struers.fr

BELGIUM (Flanders)

Struers GmbH Nederland
Zomerdijk 34 A
3143 CT Maassluis
Telefoon +31 (10) 599 7209
Fax +31 (10) 5997201
netherlands@struers.de

CANADA

Struers Ltd.
7275 West Credit Avenue
Mississauga, Ontario L5N 5M9
Phone +1 905-814-8855
Fax +1 905-814-1440
info@struers.com

CHINA

Struers Ltd.
No. 1696 Zhang Heng Road
Zhang Jiang Hi-Tech Park
Shanghai 201203, P.R. China
Phone +86 (21) 6035 3900
Fax +86 (21) 6035 3999
struers@struers.cn

CZECH REPUBLIC & SLOVAKIA

Struers GmbH Organizační složia
védeckotechnický park
Přilepská 1920,
CZ-252 63 Roztoky u Prahy
Phone +420 233 312 625
Fax +420 233 312 640
czechrepublic@struers.de
slovakia@struers.de

GERMANY

Struers GmbH
Carl-Friedrich-Benz-Straße 5
D- 47877 Willlich
Telefon +49 (0) 2154 486-0
Fax +49 (0) 2154 486-222
verkauf@struers.de

FRANCE

Struers S.A.S.
370, rue du Marché Rollay
F-94507 Champigny
sur Marne Cedex
Téléphone +33 1 5509 1430
Télécopie +33 1 5509 1449
struers@struers.fr

HUNGARY

Struers GmbH
Magyarországi Fióktelep
Tatai út 53
2821 Gyermely
Phone +36 (34) 880546
Fax +36 (34) 880547
hungary@struers.de

IRELAND

Struers Ltd.
Unit 11 Evolution@ AMP
Whittle Way, Catcliffe
Rotherham S60 5BL
Tel. +44 0845 604 6664
Fax +44 0845 604 6651
info@struers.co.uk

ITALY

Struers Italia
Via Monte Grappa 80/4
20020 Arese (MI)
Tel. +39-02/38236281
Fax +39-02/38236274
struers.it@struers.it

JAPAN

Marumoto Struers K.K.
Takanawa Muse Bldg. 1F
3-14-13 Higashi-Gotanda,
Shinagawa
Tokyo
141-0022 Japan
Phone +81 3 5488 6207
Fax +81 3 5488 6237
struers@struers.co.jp

NETHERLANDS

Struers GmbH Nederland
Zomerdijk 34 A
3143 CT Maassluis
Telefoon +31 (10) 599 7209
Fax +31 (10) 5997201
netherlands@struers.de

NORWAY

Struers ApS, Norge
Sjøskogenveien 44C
1407 Vinterbro
Telefon +47 970 94 285
info@struers.no

AUSTRIA

Struers GmbH
Zweigniederlassung Österreich
Betriebsgebiet Puch Nord 8
5412 Puch
Telefon +43 6245 70567
Fax +43 6245 70567-78
austria@struers.de

POLAND

Struers Sp. z o.o.
Oddział w Polsce
ul. Jasnogórska 44
31-358 Kraków
Phone +48 12 661 20 60
Fax +48 12 626 01 46
poland@struers.de

ROMANIA

Struers GmbH, Sucursala Bucuresti
Str. Preciziei nr. 6R
062203 sector 6, Bucuresti
Phone +40 (31) 101 9548
Fax +40 (31) 101 9549
romania@struers.de

SWITZERLAND

Struers GmbH
Zweigniederlassung Schweiz
Weissenbrunnstraße 41
CH-8903 Birmensdorf
Telefon +41 44 777 63 07
Fax +41 44 777 63 09
switzerland@struers.de

SINGAPORE

Struers Singapore
627A Aljunied Road,
#07-08 BizTech Centre
Singapore 389842
Phone +65 6299 2268
Fax +65 6299 2661
struers.sg@struers.dk

SPAIN

Struers España
Camino Cerro de los Gamos 1
Building 1 - Pozuelo de Alarcón
CP 28224 Madrid
Teléfono +34 917 901 204
Fax +34 917 901 112
struers.es@struers.es

FINLAND

Struers ApS, Suomi
Hietalahdenranta 13
00180 Helsinki
Puhelin +358 (0)207 919 430
Faksi +358 (0)207 919 431
finland@struers.fi

SWEDEN

Struers Sverige
Box 20038
161 02 Bromma
Telefon +46 (0)8 447 53 90
Telefax +46 (0)8 447 53 99
info@struers.se

UNITED KINGDOM

Struers Ltd.
Unit 11 Evolution @ AMP
Whittle Way, Catcliffe
Rotherham S60 5BL
Tel. +44 0845 604 6664
Fax +44 0845 604 6651
info@struers.co.uk

USA

Struers Inc.
24766 Detroit Road
Westlake, OH 44145-1598
Phone +1 440 871 0071
Fax +1 440 871 8188
info@struers.com