

# AbraPol-20



## Instruction Manual

Manual No.: 15887001

Date of Release GHĚ .201H





<b>Table of Contents</b>	<b>Page</b>
User's Guide .....	1
Reference Guide.....	44
Quick Reference Guide .....	95

---

Always state *Serial No* and *Voltage/frequency* if you have technical questions or when ordering spare parts. You will find the Serial No. and Voltage on the type plate of the machine itself. We may also need the *Date* and *Article No* of the manual. This information is found on the front cover.

The following restrictions should be observed, as violation of the restrictions may cause cancellation of Struers legal obligations:

**Instruction Manuals:** Struers Instruction Manual may only be used in connection with Struers equipment covered by the Instruction Manual.

**Service Manuals:** Struers Service Manual may only be used by a trained technician authorised by Struers. The Service Manual may only be used in connection with Struers equipment covered by the Service Manual.

Struers assumes no responsibility for errors in the manual text/illustrations. The information in this manual is subject to changes without notice. The manual may mention accessories or parts not included in the present version of the equipment.

**Original instructions.** The contents of this manual is the property of Struers. Reproduction of any part of this manual without the written permission of Struers is not allowed.

All rights reserved. © Struers 201H

**Struers A/S**  
Pederstrupvej 84  
DK-2750 Ballerup  
Denmark  
Telephone +45 44 600 800  
Fax +45 44 600 801

---



## **AbraPol-20**

### **Safety Precaution Sheet**

#### **To be read carefully before use**

1. The operator should be fully aware of the use of the machine according to the instruction manual.
2. The machine must be installed in compliance with local safety regulations.
3. Be aware that the machine's centre of gravity is located in the upper half of the machine.
4. Before lifting the machine, ensure that the supplied lifting boom is securely bolted to the machine.
5. When lifting the machine using a forklift, lift from front - never lift the machine from the side or the rear.
6. When lifting the machine using lifting straps, ensure that the straps are crossed and do not press on the sides of the machine.
7. The machine must be placed on a safe and stable support, which is capable of bearing the weight of this machine. Before using the machine, it must be levelled using the adjustable legs.
8. Check that the actual voltage corresponds to the voltage stated on the side of the machine and that the connections comply with local regulations.  
The machine must be earthed.
9. Make sure that the water connections are without leaks. The main water supply should be turned off or disconnected if you leave the machine unattended.
10. Alcohol based consumables: follow the current safety rules for handling, mixing, filling, emptying and disposal of the alcohol-based liquids.  
Struers recommend the use of an external exhaust system.

*AbraPol-20*  
*Instruction Manual*

- 11.** Make sure that the specimens in the specimen holder are securely fixed when operating.
- 12.** If you observe malfunctions or hear unusual noises - stop the machine and call technical service.
- 13.** The machine must be disconnected from the mains prior to any service. Wait until residual potential on the capacitors is discharged.
- 14.** Do not cycle mains power more than once every three minutes. Damage to the drive will result.
- 15.** To achieve maximum safety and lifetime of the machine, use only original Struers consumables.

---

The equipment should only be used for its intended purpose and as detailed in the Instruction Manual.

The equipment is designed for use with consumables supplied by Struers. If subjected to misuse, improper installation, alteration, neglect, accident or improper repair, Struers will accept no responsibility for damage(s) to the user or the equipment.

Dismantling of any part of the equipment, during service or repair, should always be performed by a qualified technician (electromechanical, electronic, mechanical, pneumatic, etc.).

---



# User's Guide

Table of Contents	Page
<b>1. Getting Started</b>	
Checking the Contents of the Packing Box.....	3
Additional Dosing Unit (accessory).....	3
Outlet Kit (accessory).....	3
Accurate Material Removal Unit (accessory).....	3
Unpacking and Placing AbraPol-20 .....	3
Getting Acquainted with AbraPol-20 .....	4
Power Supply .....	6
Supplying Compressed Air.....	7
Connection to an External Exhaust System.....	7
Water Outlet.....	8
Mounting a Recirculation Cooling Unit (accessory) .....	9
Mains Water Connection.....	10
Placing Bottles in the Dosing Unit.....	10
Mounting an Additional Dosing Unit (accessory) .....	11
Mounting the Outlet Kit (accessory).....	12
Mounting the Stock Removal Sensor (accessory) .....	15
<b>2. Operation</b>	
Front Panel.....	16
Front Panel Controls .....	17
Software Settings.....	18
Setting the Language.....	21
Setup Bottle Configuration .....	23
Reading the Display.....	26
Sleep Mode.....	27
Changing/Editing Values.....	28
Numeric Values.....	28
Alphanumeric Values .....	29
Text Values .....	31
Programming a Preparation Step.....	32
Mounting a Preparation Disc (300 or 350 mm) .....	32
Inserting the Specimen Holder.....	32
Adjusting the Specimen Holder Position .....	33
Starting the Preparation Process (Struers Method) .....	35
Stopping the Preparation Process .....	35
Manual Functions.....	36

### **3. Maintenance**

General Cleaning .....	38
Cooling Tank.....	38
Painted Surfaces.....	38
Weekly Service .....	38
Checking the Recirculation Cooling Unit.....	38
Monthly service .....	38
Replacing the Cooling Water .....	38
Cleaning of Tubes.....	39
Yearly Service .....	43
Inspection of Cover .....	43



## 1. Getting Started

### Checking the Contents of the Packing Box

In the packing box you should find the following parts:

- 1 AbraPOL-20 (Grinding polishing machine)
- 1 Outlet hose 2.5 m with straight PVC pipe, for connection to external cooling unit
- 1 Hose clamp, 32-50 mm
- 1 Inlet hose for tap water 3/4" (2m)
- 1 Filter gasket
- 1 Gasket  $\varnothing 11/\varnothing 24$  (1.5 mm)
- 1 Reduction ring with gasket
- 1 Hose for compressed air
- 1 Hose connection for compressed air
- 2 Hose clamps, 12 mm
- 2 Silicone tubes for use with alcohol based lubricants
- 2 Bottles, 1/2 l, with lids  
(4 Bottles if delivered with Additional Dosing Unit)
- 1 Bottle, 1 l, with lid  
(2 Bottles if delivered with Additional Dosing Unit)
- 1 Fork spanner (24 mm)
- 1 Set of Instruction Manuals

*Additional Dosing Unit (accessory)* Three additional pumps for dosing of OP-Suspension, lubricants and suspensions.

*Outlet Kit (accessory)* Shift valve for recirculation cooling unit or drain.

*Accurate Material Removal Unit (accessory)* For accurate removal of material. Stops process after required amount of material has been removed.

### Unpacking and Placing AbraPol-20

AbraPol-20 should be placed on a plane and horizontal floor, capable of bearing the weight of this machine, please refer to the Technical Data section.

The machine must be placed close to the power supply, compressed air, water mains and water outlet facilities.

- Unscrew the nuts from the transport brackets fixing the machine to the pallet.
- Lift the machine from the pallet by means of a forklift truck from the front, and place in a suitable location.
- Remove the safety-springs from the front crossbar, and remove the bar.

***Important***

If necessary, turn the adjustable feet so that the machine stands firmly and is level.

**Getting Acquainted with  
AbraPol-20**

Take a moment to familiarise yourself with the location and names of the AbraPol-20 components.

Front view

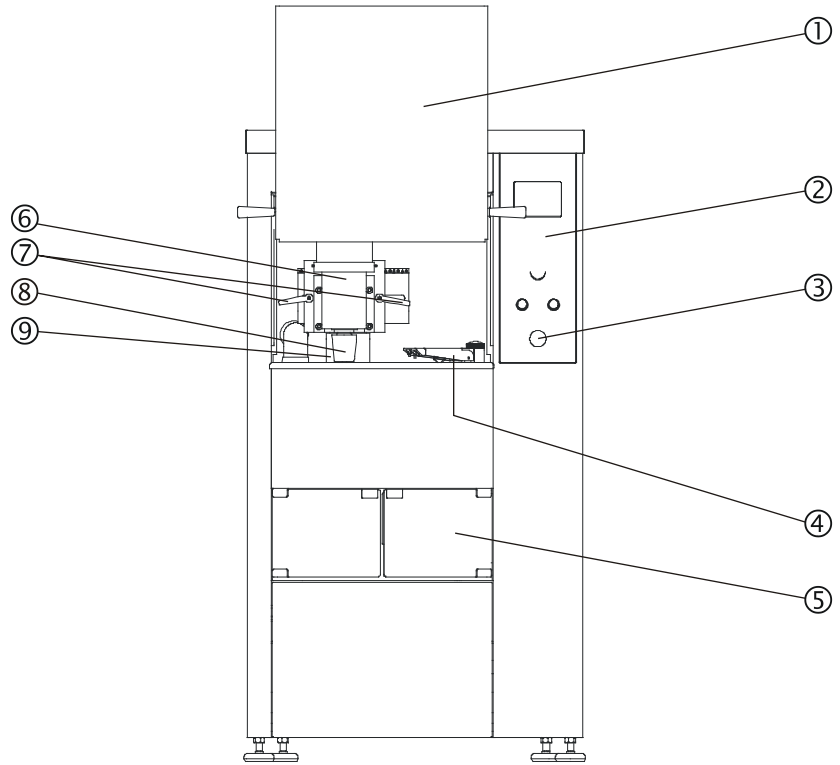

- ① Safety guard
- ② Control panel,  
(see 2. Basic Operations)
- ③ Emergency Stop
- ④ Nozzle block
- ⑤ Bottle unit
- ⑥ Specimen holder motor
- ⑦ Handle for adjusting specimen holder position
- ⑧ Specimen quick coupling
- ⑨ LED-light to illuminate preparation disc

Side views

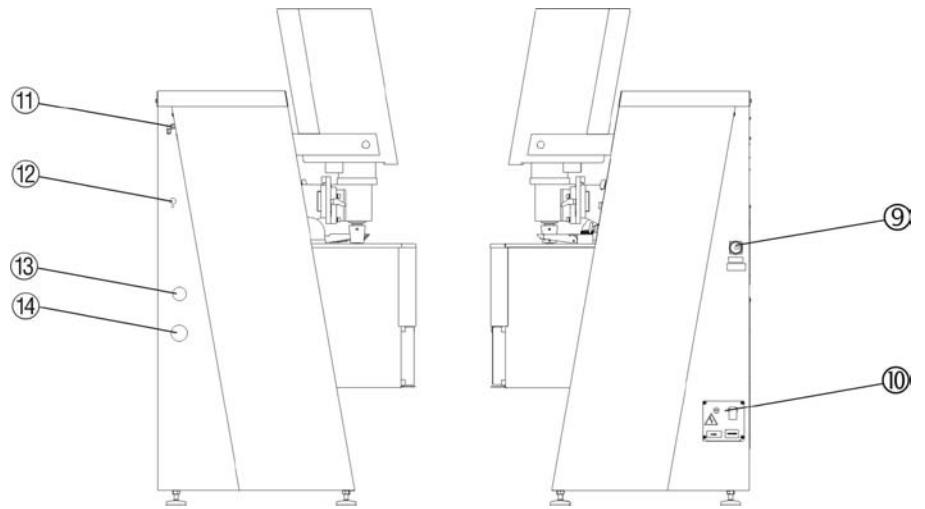

- ⑨ Mains power switch
- ⑩ Electrical connections
- ⑪ Compressed air inlet
- ⑫ Adjustment screw for speed of Sample Mover head
- ⑬ Connection to exhaust
- ⑭ Opening for water outlet

Rear view

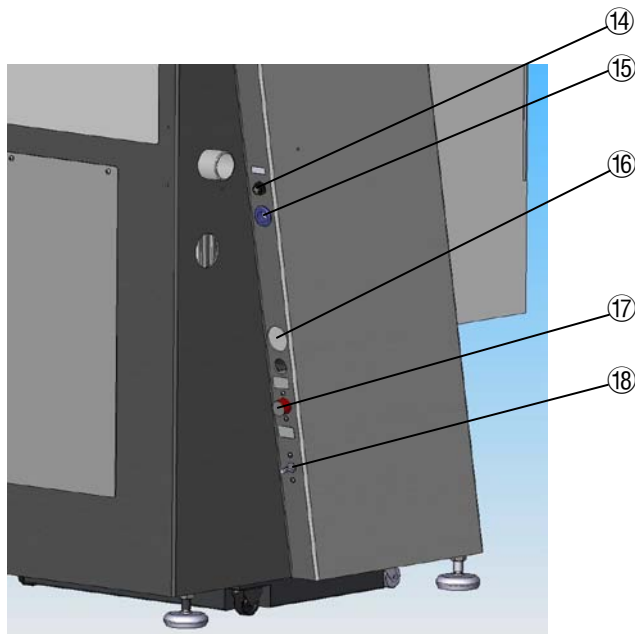

- ⑭ Connector for Recirculation Cooling Unit
- ⑮ Hole for lead from Recirculation Cooling Unit
- ⑯ Water outlet (when shift valve is fitted)
- ⑰ Connection for water inlet
- ⑱ Regulation valve for disc cooling

## Power Supply

**IMPORTANT**

Check that the mains voltage corresponds to the voltage stated on the type plate on the side of the machine.

**IMPORTANT**

AbraPol-20 must be connected with an electric cable and an additional wire for earth connection which **MUST** be hard-wired into the mains (ref. EN 50178 / 5.2.11.1)

**Important:**

**For Electrical Installations with Residual Current Circuit Breakers**

For AbraPol-20 connected to electrical installations with residual current circuit breakers, a residual current circuit breaker, type B, 30 mA is **REQUIRED** (ref. EN 50178 / 5.2.11.1).

**For Electrical Installations without Residual Current Circuit Breakers**

The equipment must be protected by an insulation transformer (double-wound transformer)

Please contact a qualified electrician to verify which option is suitable for the local installation setup.

Both requirements refer to the European standard EN 50178 / 5.2.11.1. Similar standards apply in North America.

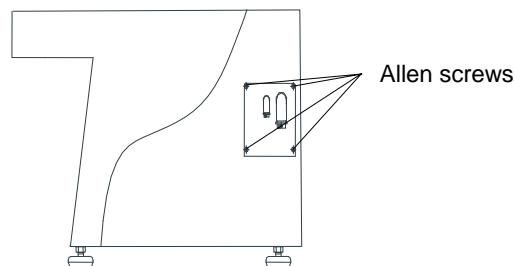

- Remove the 4 Allen screws, on the right hand side of the machine, securing the electrical panel, and let the electrical panel rest on the tabs.
- Lead the cable through the conduit in the panel and connect the 3 phases and 2 earth connections according to local regulations.
- The second Protective Earth must be earthed by connection to a terminal marked  $\oplus$  or PE *alternatively*, use a system whereby there is an automatic disconnection of the supply in case of loss continuity of the protective conductor.

### **Supplying Compressed Air**

- Connect the compressed air supply with the inlet on the rear, left side of the machine by means of the air hose and the hose connection delivered with the machine.
- Fasten the air hose with a hose clamp.

The pressure supply should be 6-10 bar and should be supplied either from a central compressor, portable compressor with compressed air reservoir or compressed-air bottle. A capacity of 20 l/min at atmospheric pressure is sufficient.

Please refer to the section on Technical Data for recommended air quality.

### **Connection to an External Exhaust System**

An exhaust system should be connected when using alcohol based suspensions or lubricants.

- Connect a 50 mm pipe to the outlet at the rear of the machine, on the left and connect to the exhaust system.

Recommended capacity for exhaust system: 180m<sup>3</sup>/h at 0mm water gauge.

## Water Outlet

AbraPol-20 is delivered with a short piece of hose (0.8 m) attached to the water outlet. This is sufficient to connect the machine to a recirculation cooling unit placed underneath the machine.

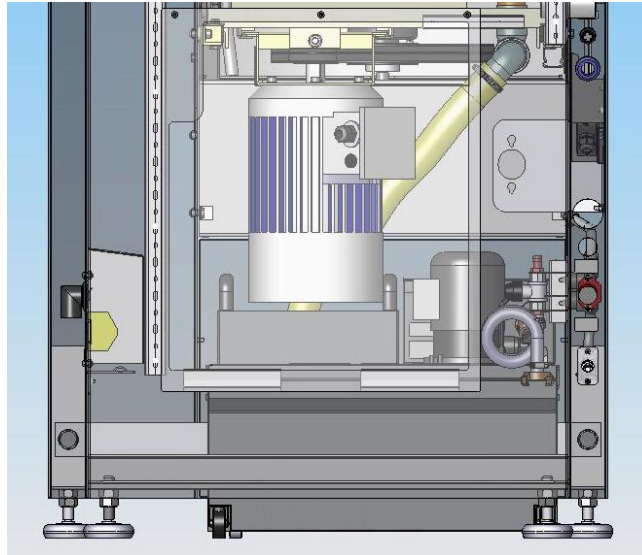

To connect the machine to an external drain, lengthen the outlet hose with the longer piece delivered with the machine (2.5 m).

- Insert the straight piece of pipe halfway into the second piece of hose (2.5 m) and secure with a hose clamp. Lubricate with grease or soap to facilitate insertion.
- Insert the other end of the straight pipe into the outlet hose mounted on AbraPol-20 and secure with a hose clamp.
- Check that the outlet hose slopes downwards towards the drain along the whole of its length. Shorten the hose to the required length.

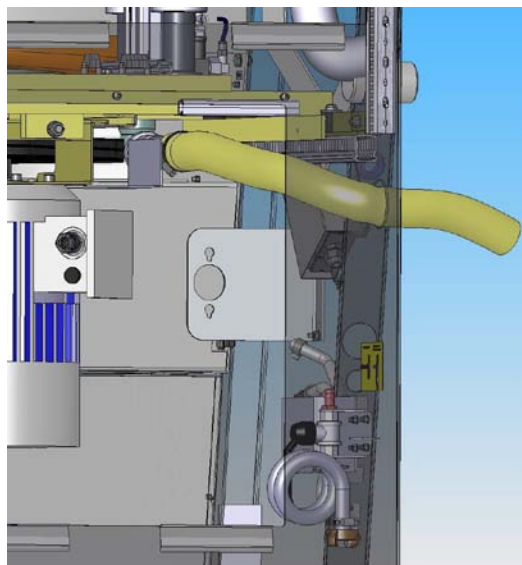

**Mounting a Recirculation Cooling Unit (accessory)**

Please refer to the manual for the Recirculation Cooling Unit for details.

***IMPORTANT***

Always maintain the correct concentration of Struers Additive in the cooling water (percentage stated on the Additive container).  
Remember to top up with Struers Additive each time you refill with water.

Whenever the recirculation tank is removed from the compartment underneath the AbraPol-20, place the drain tube in the tube holder to avoid dripping.  
Remember to put the tube back into the tank before starting the machine.

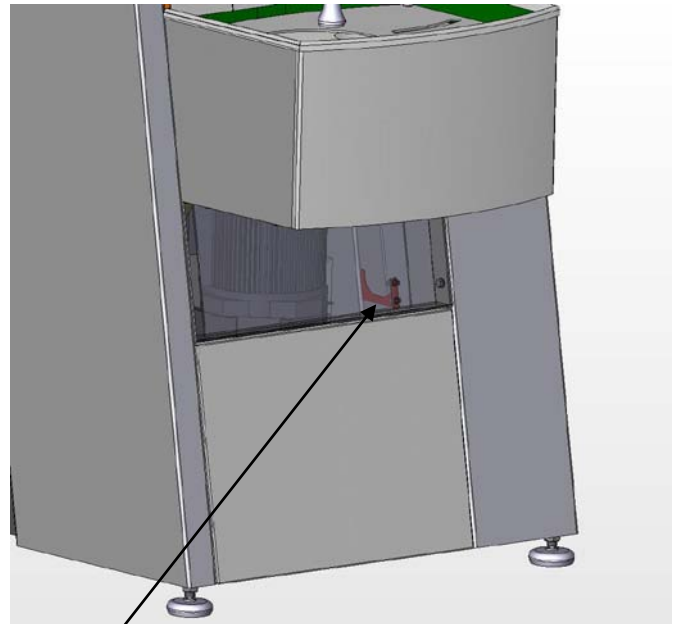

Tube holder

## **Mains Water Connection**

When the AbraPol-20 is used without a Recirculation Cooling Unit, with the second dosing unit for dosing of OP-Suspensions or when disc cooling is required, AbraPol-20 must be connected to water directly from the mains.

- Mount the pressure hose onto the water inlet tube on the back of the AbraPol-20.
  - Insert the filter gasket in the coupling nut with the flat side against the pressure hose.
  - Tighten the coupling nut completely.
- Mount the other end of the pressure hose on the water mains tap for cold water:
  - Mount the reduction ring with gasket on the water mains tap, if necessary.
  - Introduce the gasket and tighten the coupling nut completely.

## **Placing Bottles in the Dosing Unit**

- Place the filled bottles in the dosing unit and connect the tubing.
- Enter the bottle details in the Bottle Configuration menu to make them available for preparation methods. See “Setup Bottle Configuration”.

The tubes can easily go through the bottle unit to reach larger containers placed on the floor e.g. Lubricants.

***Nb!***

OP-Suspensions can not be placed on the floor.



**Mounting an Additional Dosing Unit (accessory)**

- Switch off the machine.
- Open the doors to the bottle unit.

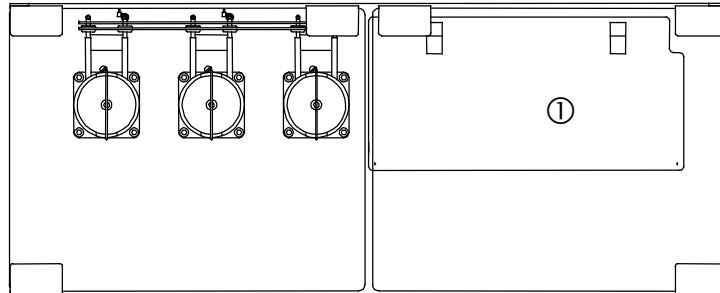

- Remove the rectangular cover plate ① with a 3 mm Allen key.
- Loosen the hose clamp on the water hose and remove the plug from the hose.
- Connect the hose to the tube at the back of the Additional Dosing Unit and secure it with the hose clamp.
- Connect the electrical plugs from the Additional Dosing Unit to the PCB inside the machine. (see fig.)  
Start from the left with pump 4 to the left connection, pump 5 to the second connection, pump 6 to the third connection and finally the plug with the all black wires to the last connection on the right.

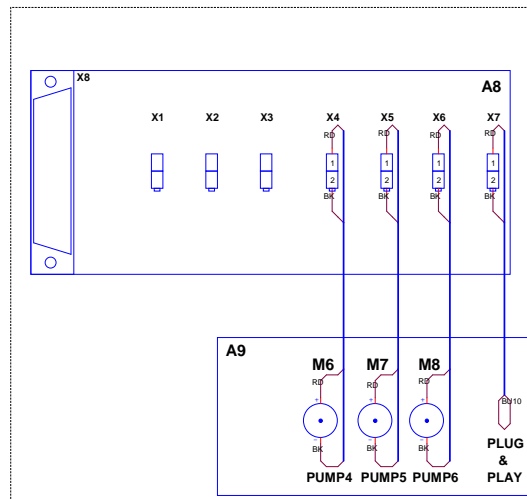

**NB**  
Remember the earth connections.

- Mount the Additional Dosing Unit using the four screws.
- Connect the tubes to the inlets/outlets of the dosing pumps.
- Switch the machine back on again and configure the new pumps.

**NB**  
OP-suspensions can only be used in bottle 4.

**Mounting the Outlet Kit  
(accessory)**

The shifting valve can be mounted from the rear of the AbraPol-20 (recommended) or from the front.

- Switch off the machine
- To install from the rear:  
Remove the lower back cover plate
- To install from the front:  
Remove lower cover plate and the Recirculation Cooling Unit, if there is one.
- Take the entire unit, and place it in position by letting the two Allen bolts slide into the slots located in the left rear side.

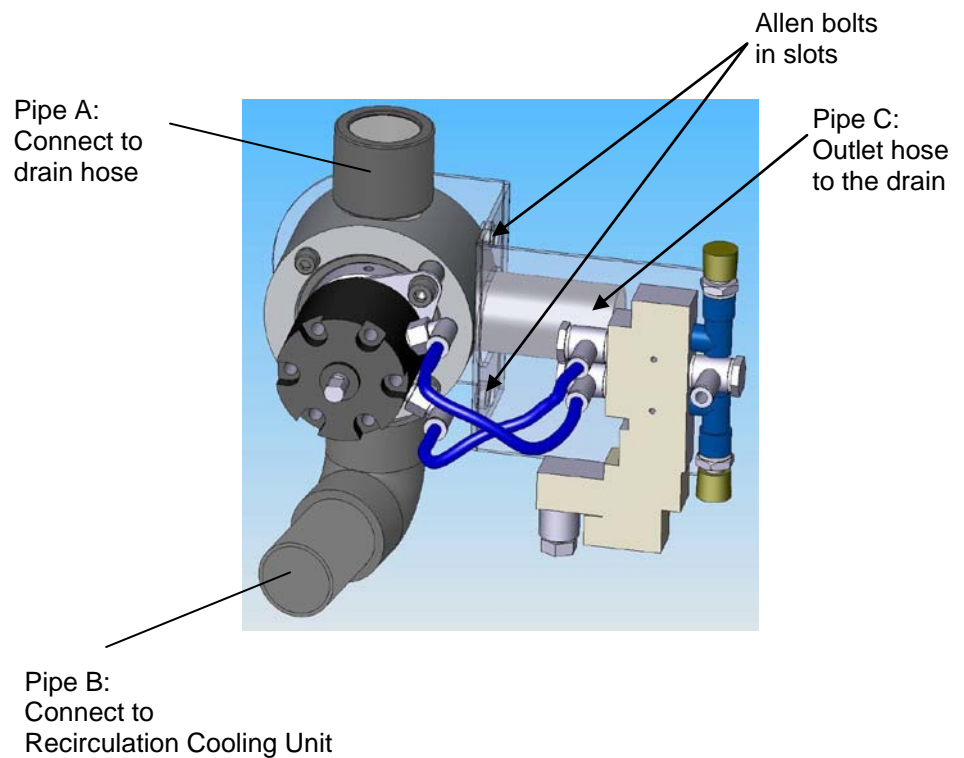

- Tighten the Allen bolts.

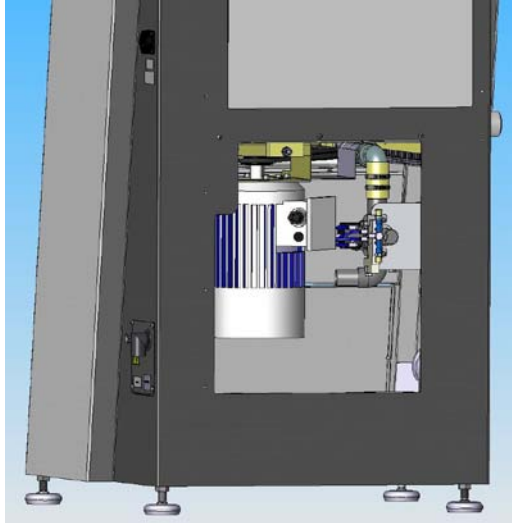

- Cut the water outlet hose to the required length and mount onto pipe **A** of the Shifting Valve, clamp using a hose clamp.
- Take another piece of drain hose and check that it is long enough to reach the Recirculation Cooling Unit (Ø40 mm and 0.5m long). Mount onto pipe **B** and clamp using a hose clamp.
- Connect to the Recirculation Cooling Unit.
- Connect a piece of drain hose from the outlet at the rear (pipe **C**) and lead to the drain. Check that the outlet hose slopes downwards towards the drain along the whole of its length.
- Reposition the Recirculation Cooling Unit.
- Make sure that the hoses do not interfere with the belts.

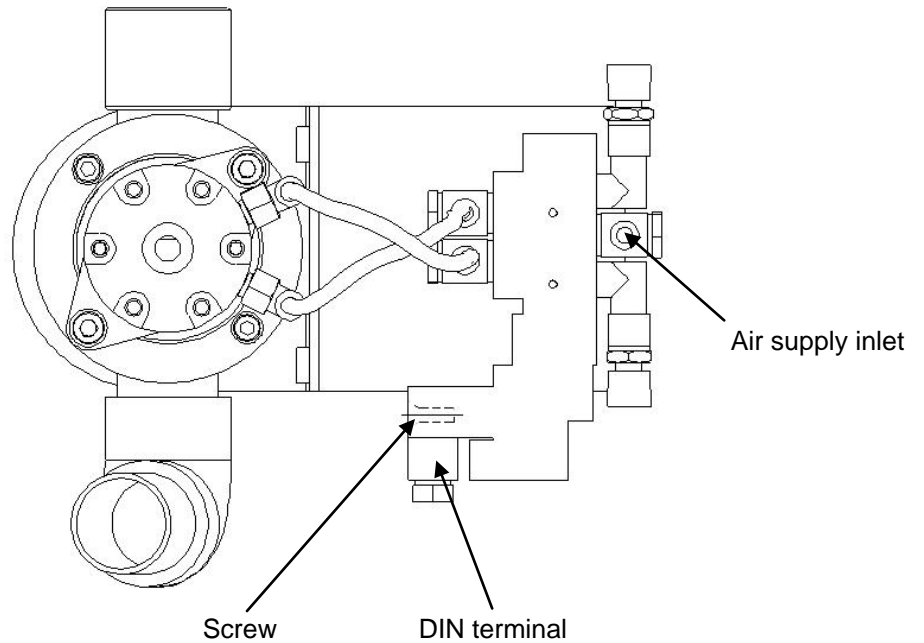

- Locate the electrical cable for the air solenoid valve (located on the inner left side of the machine) and remove the cap covering the stripped wires.
- Open the cover of the DIN terminal by removing the screw and connect the wires to the terminals.
- Replace the cover for the DIN terminal.

**Note:**

It is not important to which terminal the wires are connected, each wire can be connected to either terminal.

- Find the air supply hose and cut off the plug (stopper). Fix the cut end into the air supply inlet.
- Replace the front cover and reconnect main power.

#### Adjusting Disc Cooling

Should the rate of disc cooling require adjustment:

- Loosen the contra nut and turn the regulator screw to the required rate.
- Re-tighten the contra nut.

### Mounting the Stock Removal Sensor (accessory)

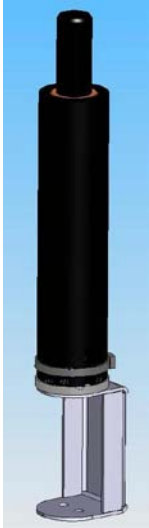

- Disconnect main power.
- Remove the upper back cover plate.
- Take the Stock removal unit with the stand and position over the predrilled holes on the machine.
- Secure the Stock Removal Sensor in place using two M5 screws and washers (use a 4 mm Allen key).

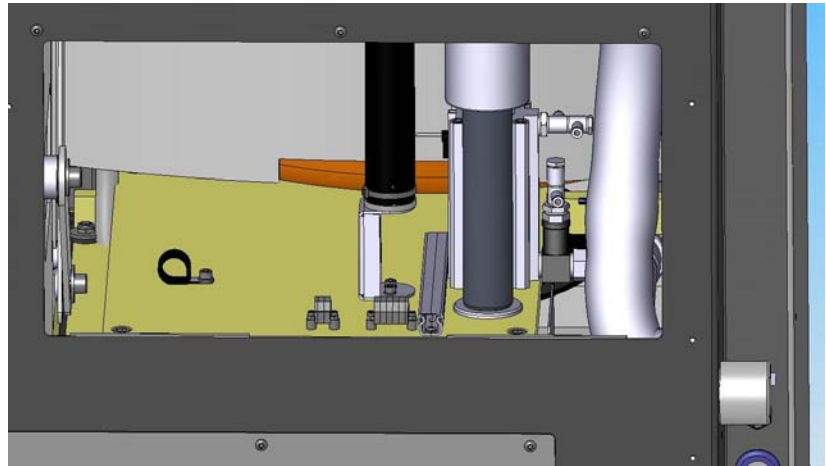

- Connect the wire to the connector X22 (remember to lead the wire in the trunking).

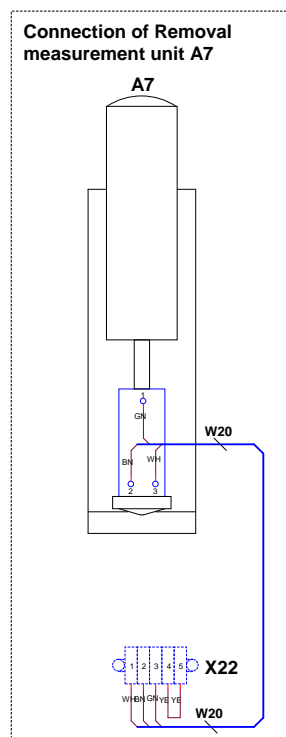

- Replace the cover plate
- Reconnect main power and follow the instructions on the screen, using the tools supplied and the calibrating sticks.







## 2. Operation

### Front Panel

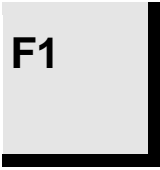
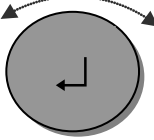
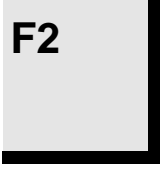
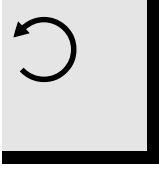
For more information also see page on Front Panel Controls.

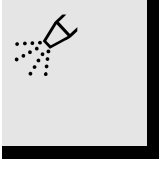

**Front Panel Controls**

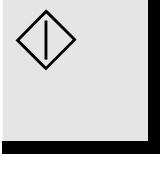
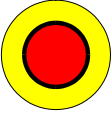
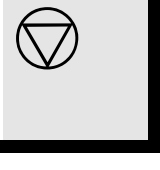
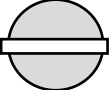
Name	Key	Function	Name	Key	Function
FUNCTION KEY		Controls for various purposes. See the bottom line of the individual screens.	Push/Turn Knob		Used for entering and changing steps and parameters. Combined cursor and enter key.
FUNCTION KEY		Controls for various purposes. See the bottom line of the individual screens.	DISC		Starts the rotation of the disc.
FUNCTION KEY		Controls for various purposes. See the bottom line of the individual screens.	Water		Activates the water flow. Remember to adjust the flow on the water tap.
FUNCTION KEY		Controls for various purposes. See the bottom line of the individual screens.	LUBRICANT		Manual dosing of lubricant
Esc		Leaves the present menu or aborts functions/changes.	ABRASIVE		Manual dosing of abrasive
START		Starts the preparation process.	EMERGENCY STOP		- Push the red button to stop. - Turn the red button clockwise to release.
STOP		Stops the preparation process.	MAIN SWITCH		The main switch is located on the right side of the machine.

## **Software Settings**

Switch on the power at the main switch located at the right hand side of the machine.

The following display will appear briefly:

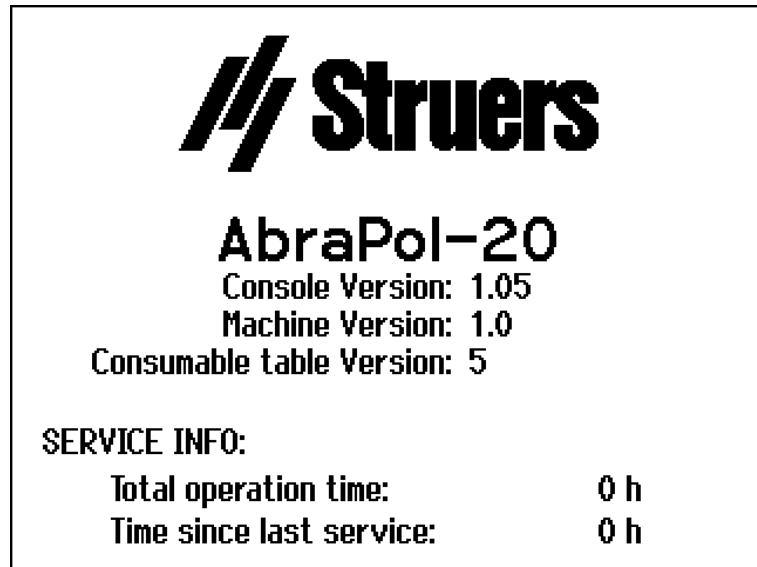

This screen shows the software versions of both the operating console and the machine, as well as the version number of the consumables table.

Additionally some service information is supplied; the total operation time and the time since the last service of the machine.

The display will then change to the last screen shown before AbraPol-20 was switched off, usually a preparation method.



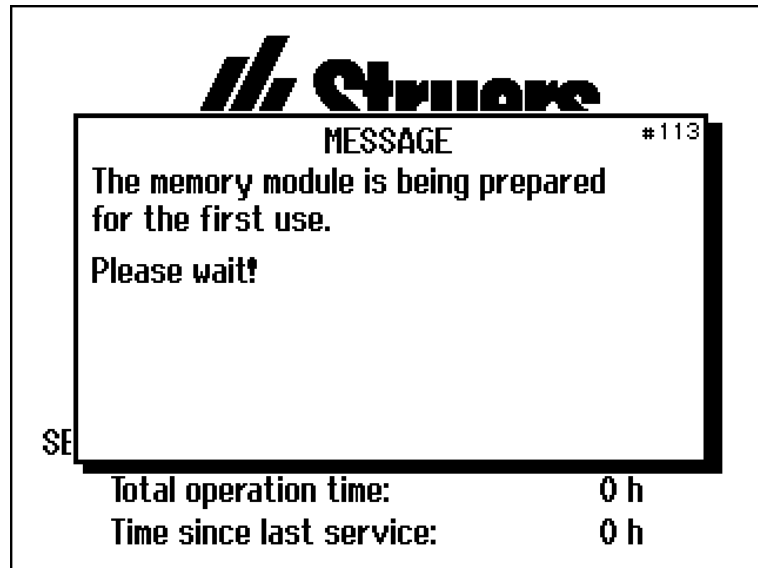

When switching on AbraPol-20 for the first time, the following screen will appear for a short while:

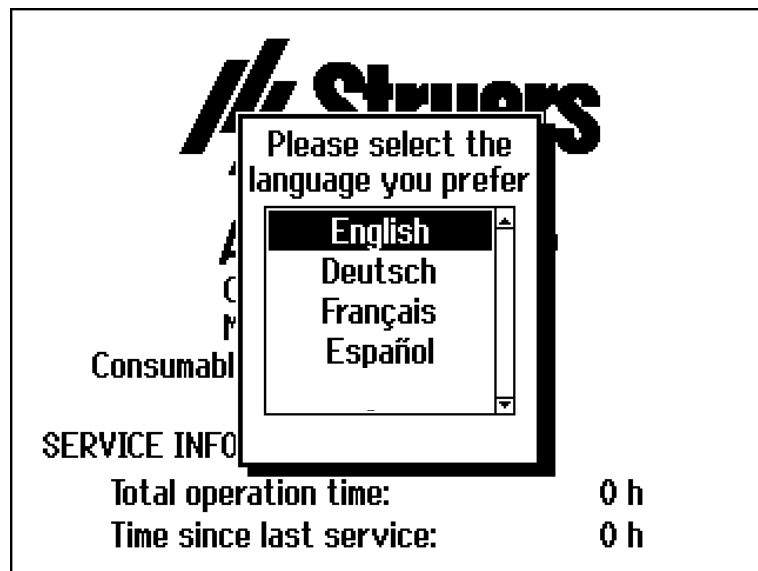

A pop-up menu will appear to request selection of the language of your choice.





- ↓
-  Turn knob to select the language you prefer.
- ↓
-  Push knob to accept the language.

Then the MAIN MENU will then appear.  
If the heading in the display is different, press Esc, until the MAIN MENU appears.

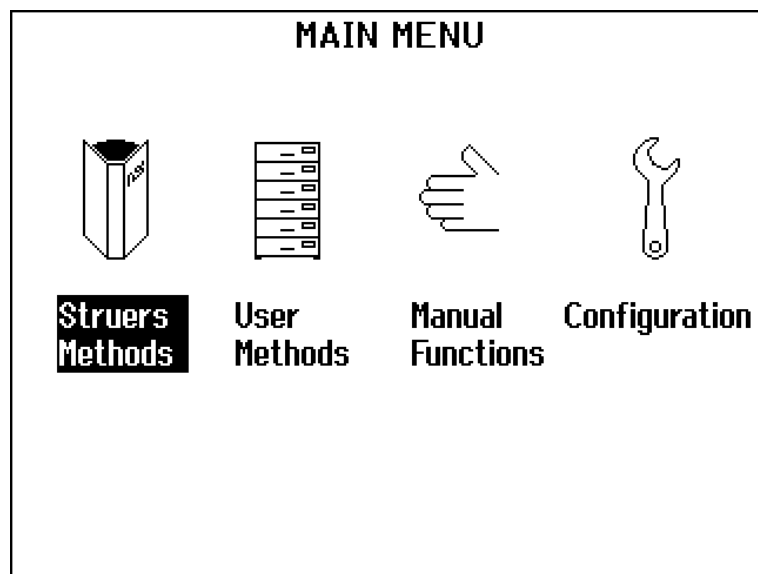
The MAIN MENU is the highest level in the menu structure. Pre-defined Struers methods, your own methods, manual functions or the configuration menu can then be selected.



↓  
 Turn knob to select *Configuration*.

↓  
 Push knob to activate the *CONFIGURATION MENU*.

↓

Setting the Language

 Turn knob to select *Options*.

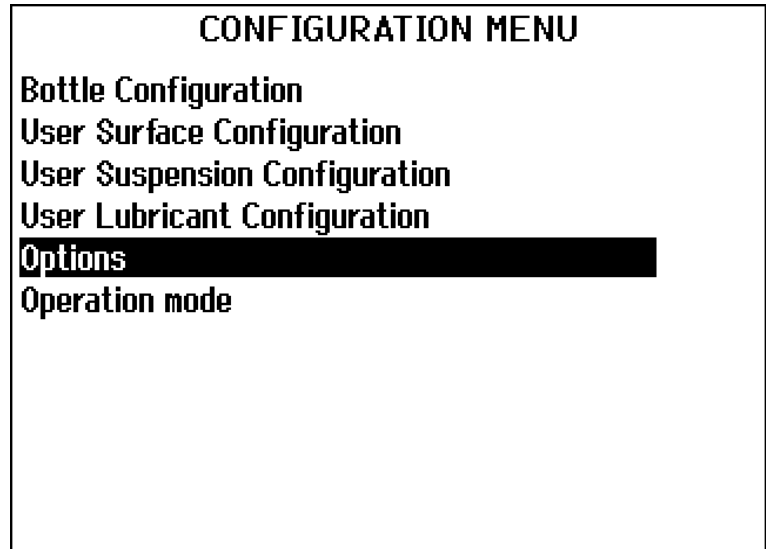

 Push knob to activate the *OPTIONS* menu.

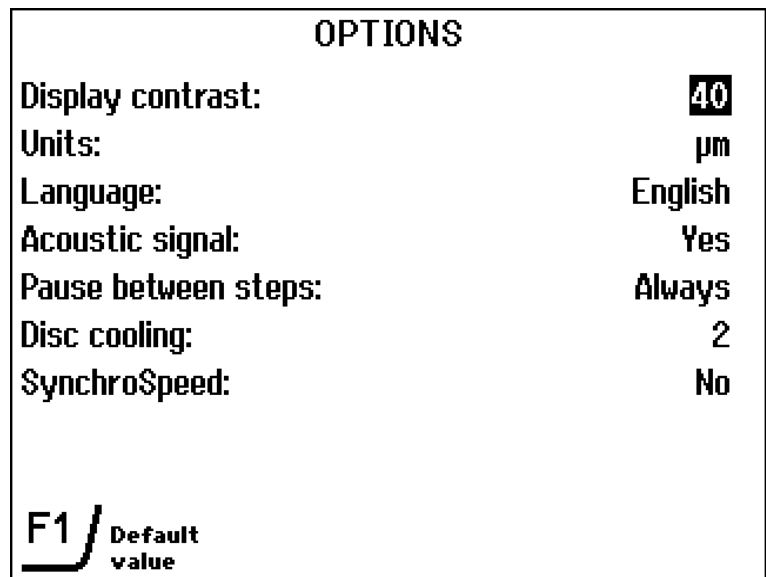

 Turn knob to select *Language*.





Push knob to activate the *SELECT LANGUAGE* pop-up menu.

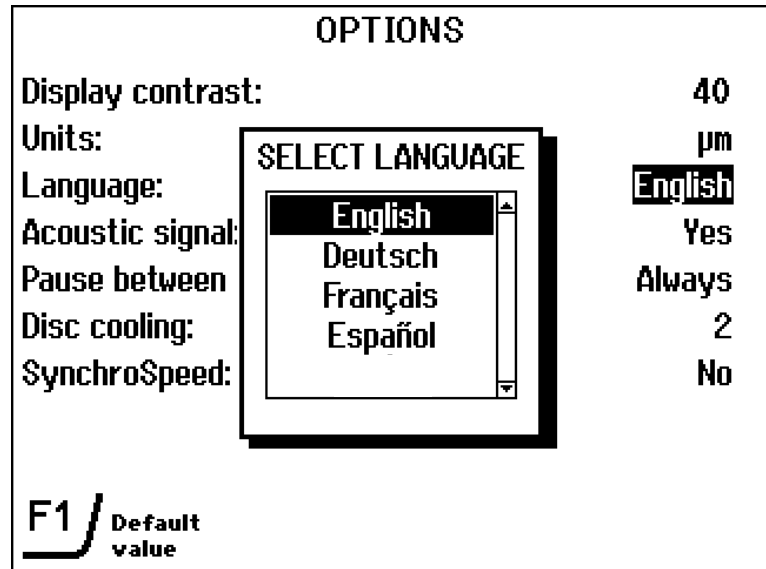

Turn knob to select the language you prefer.



Push knob to accept the language.

The *CONFIGURATION MENU* now appears in the language you have chosen.



Press Esc to return to the *MAIN MENU*.

Setup Bottle Configuration

 Turn knob to select *Bottle Configuration*.



CONFIGURATION MENU	
<b>Bottle Configuration</b>	
User Surface Configuration	
User Suspension Configuration	
User Lubricant Configuration	
Options	
Operation mode	



 Push knob to activate the *BOTTLE CONFIGURATION* menu.



BOTTLE CONFIGURATION		
Bottle	Lub./Susp.	Type
1	<b>Lubricant</b>	Undefined
2	Lubricant	Undefined
3	Lubricant	Undefined
4	Suspension	Undefined
5	Lubricant	Undefined
6	Lubricant	Undefined

OP-Suspension in bottle 4 only



 Turn knob to select which bottle to configure.



Push knob to toggle between Lubricant and Suspension.



Turn knob to move to *Type*.

BOTTLE CONFIGURATION		
Bottle	Lub./Susp.	Type
1	Lubricant	Undefined
2	Lubricant	Undefined
3	Lubricant	Undefined
4	Suspension	Undefined
5	Lubricant	Undefined
6	Lubricant	Undefined

OP-Suspension in bottle 4 only



Push knob to activate the select type menu.

BOTTLE CONFIGURATION		
Bottle	Lub./Susp.	Type
1	L	
2	L	
3	L	
4	S	
5	L	
6	L	

**SELECT LUBRICANT TYPE**

DP-lub., water free

DP-lub., water based

User defined

Undefined

OP-Suspension in bottle 4 only



Turn and push knob to select type of Lubricant/Suspension.

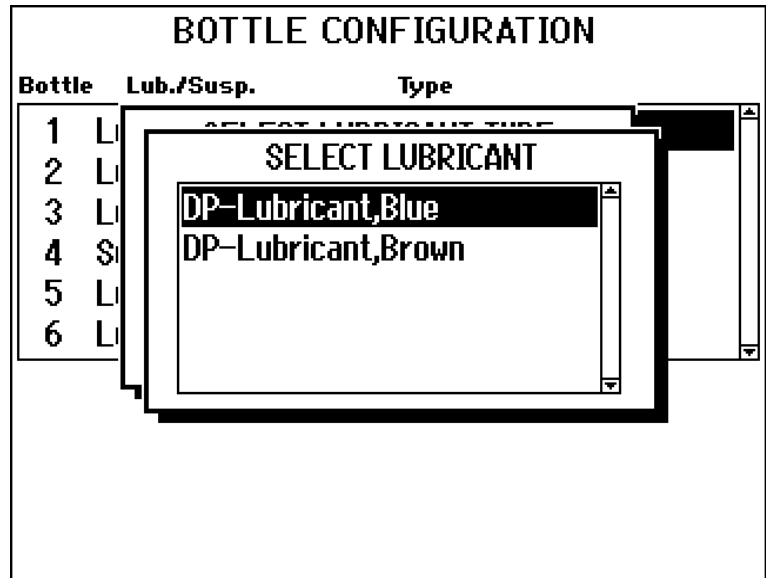

Turn and push knob to select an option.

Repeat this procedure for all the bottles in use.



Press Esc twice to return to the *Main Menu*.

**NB**

The different suspensions and lubricants used must always be defined here so that AbraPol-20 can locate the correct suspension or lubricant.

## Reading the Display

The display can show various kinds of information, for example parameters of a preparation method, or the ongoing process. An example of the screen for a preparation method is shown below:

**EDIT METHOD - Steel**

Surface	Susp.	Lub.	µm or Time
<b>1 Piano 22</b>		<b>Water</b>	<b>1m 00s</b>
2 Allegro	DiaP.All		3m 00s
3 Dac	DiaP.Dac		1m 30s
4 Chem	OP-S		1m 00s
5 Empty Step			

Process mode: \_\_\_\_\_ Time \_\_\_\_\_

Disc diameter: 300 mm

**F1** Copy      **F3** Delete

- A Heading.
- B Inverted text: cursor position.
- C Function key options

During the process the screen could look as follows:

**PROCESS STARTED - Steel**

Remaining process time: **0m 46s**

Surface	Susp.	Lub.	µm or Time
<b>1 Piano 22</b>		<b>Water</b>	<b>1m 00s</b>
2 Allegro	DiaP.All		3m 00s
3 Dac	DiaP.Dac		1m 30s

EDIT Step parameters:

Force: **180N**

Lubricant dosing level: **ON**

- A Time remaining in currently running step.
- B Preparation step currently running.



*Sleep Mode*

To increase the lifetime of the display, the backlight is dimmed automatically if AbraPol-20 has not been used for 15 min. Press any key to re-activate the backlight.

***Please Note***

The sample screens in this Instruction Manual show a number of possible texts. The actual display screen may differ from the samples in the Manual.

## Changing/Editing Values

Depending on the type of value, there are two different ways of editing.

STRUERS METHODS can not be edited or changed in any way, this is only valid for USER METHODS and CONFIGURATION.

### Numeric Values



Turn knob to select the value to be changed, e.g. Force:



EDIT METHOD STEP – Step No 1	
Surface:	Piano 220
Lubricant:	Water
Process Time:	1 m 00 s
Force:	<b>180N</b>
Rotation speed (disc / holder):	300/300 rpm
Sample holder direction:	
Process mode:	Time
Disc diameter: 300 mm	
F1	F2
Prev.	Next



Push knob to edit the value.



A scroll box appears around the value.

EDIT METHOD STEP – Step No 1	
Surface:	Piano 220
Lubricant:	Water
Process Time:	1 m 00 s
Force:	<b>180</b>
Rotation speed (disc / holder):	300/300 rpm
Sample holder direction:	
Process mode:	Time
Disc diameter: 300 mm	
F1	F2
Prev.	Next



 Turn knob to increase or decrease the numeric value.





 Push knob to accept the new value. (Pressing Esc aborts the changes, preserving the original value.)

*Alphanumeric Values*

 Turn knob to select the alphanumeric value to be changed, e.g. *Surface*



EDIT METHOD STEP – Step No 1	
Surface:	<b>Piano 220</b>
Lubricant:	Water
Process Time:	1 m 00 s
Force:	180 N
Rotation speed (disc / holder):	300/300 rpm
Sample holder direction:	
Process mode:	Time
Disc diameter: 300 mm	
F1 	F2 
Prev.	Next



 Push knob to edit the value.



A pop-up menu appears.

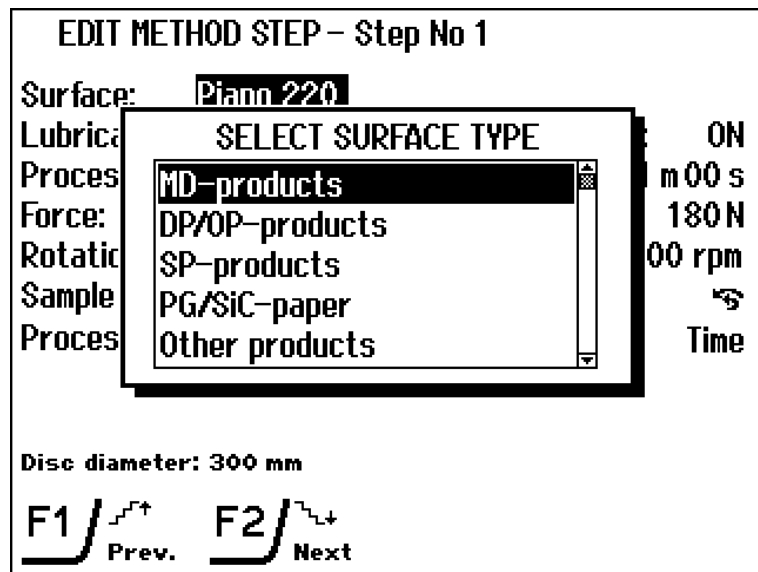

↓

Turn knob to select the correct choice.



↓

Push knob to accept the new selection and to continue or to return to the previous screen. (Pressing Esc aborts the changes, preserving the original setting.)

Text Values



 Turn knob to select the parameter to be changed, e.g. *Process mode*.



EDIT METHOD STEP – Step No 1	
Surface: Piano 220	
Lubricant: Water	Level: ON
Process Time: 1 m 00 s	
Force: 180 N	
Rotation speed (disc / holder): 300/300 rpm	
Sample holder direction: ↻	
Process mode: <b>Time</b>	
Disc diameter: 300 mm	
F1  Prev.	F2  Next



 Push knob to change the value.

EDIT METHOD STEP – Step No 1	
Surface: Piano 220	
Lubricant: Water	Level: ON
Removal: 50 µm	
Force: 180 N	
Rotation speed (disc / holder): 300/300 rpm	
Sample holder direction: ↻	
Process mode: <b>Removal</b>	
Disc diameter: 300 mm	
F1  Prev.	F2  Next
F4  Save	

### **Programming a Preparation Step**

Different preparation steps can be programmed individually in regard of time, speed of disc, water, type and dosing of lubricant and suspension. These steps can be combined in a number of different ways so that different materials can be prepared without having to repeat the programming.

### **Mounting a Preparation Disc (300 or 350 mm)**

- Move the nozzle block to the side.
- Place the disc on the turntable and move it until the three pins engage with the holes in the turntable.

### **Inserting the Specimen Holder**

- Place the specimen holder under the quick coupling.
- Press and hold the black flange of the column down with your thumbs while guiding the pressure tap of the specimen holder into the coupling.
- Release the black flange.
- Turn the specimen holder until the three pins engage with the corresponding holes.

### **Adjusting the Specimen Holder Position**

The position of the specimen holder has to be adjusted correctly in relation to the preparation disc to get the best possible preparation results.

- Loosen the two handles located on each side of the specimen holder motor.
- The specimen holder motor can now be moved manually to the sides. The eccentricity can be read on the scale on the specimen holder motor.
- When the correct position is found, fasten the handles again.

For very precise adjustments a special function is available in the *Manual Functions* menu



Turn knob to select *Manual Functions*.

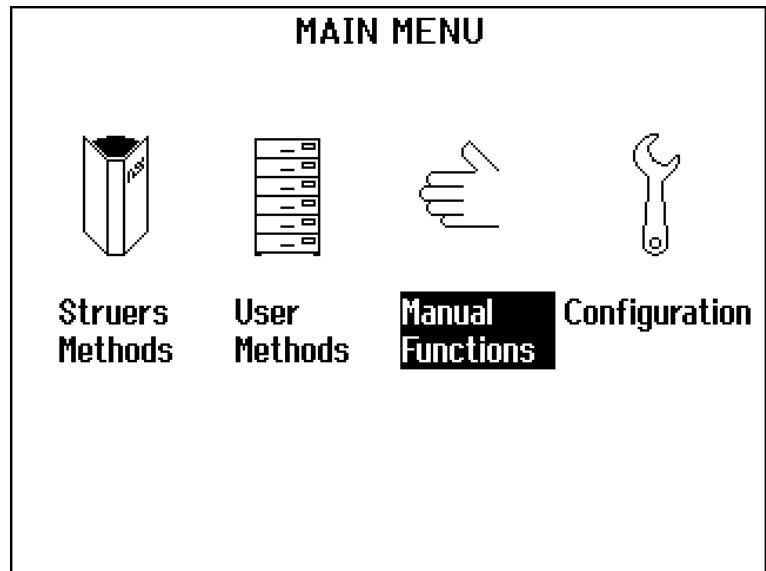

Push knob to activate the *Manual Functions* Menu.



Turn knob to select *Sample mover UP/DOWN*.

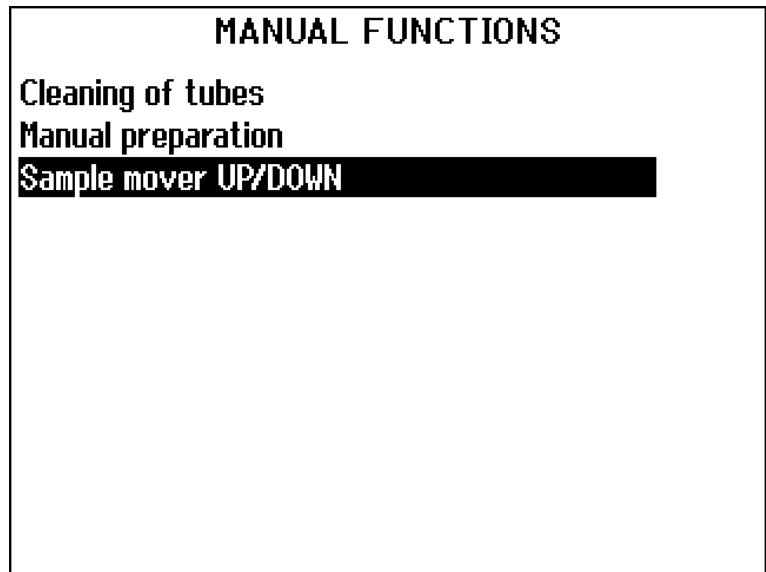

Push knob to enter the *SAMPLE MOVER UP/Down* menu.

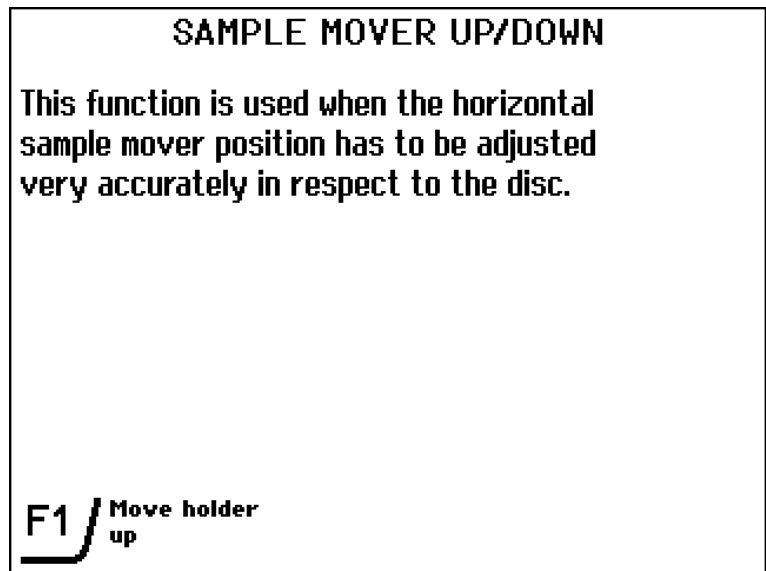

Press **F1** to move the specimen holder down. The specimen holder moves down at the lowest possible force (and without rotation) and the holder can now be positioned precisely as required. Press **F1** again to move the holder up.



### **Starting the Preparation Process (Struers Method)**

- Check that the splash ring is in place.
- Press **ESC** to get to the *Main Menu*.
- Select *Struers Methods* in the *Main Menu* by turning the knob.
- Push the knob to enter the *Struers Methods* menu.
- Turn the knob to select a Struers Method.
- View Method by pushing the knob.
- Place the required preparation surface on the MD-Disc.
- Insert the specimen holder into the coupling.
- Close the safety guard.
- Start the preparation by pressing the Start button ◊.

### **Stopping the Preparation Process**

When the time has elapsed the preparation disc will automatically stop and the specimen holder will return to its initial position. The machine is now ready for the next step.

- A preparation step can be stopped at any time during the process by pressing the key STOP Ⓢ.
- A process can also be stopped using the emergency stop button. The emergency stop button must be pulled outwards again to release it before the machine can be restarted. The sample mover will return to its initial position before the process can be started again.

## Manual Functions

Manual preparation can also be carried out from the *Manual Functions* menu.



Turn knob to select *Manual Functions*.

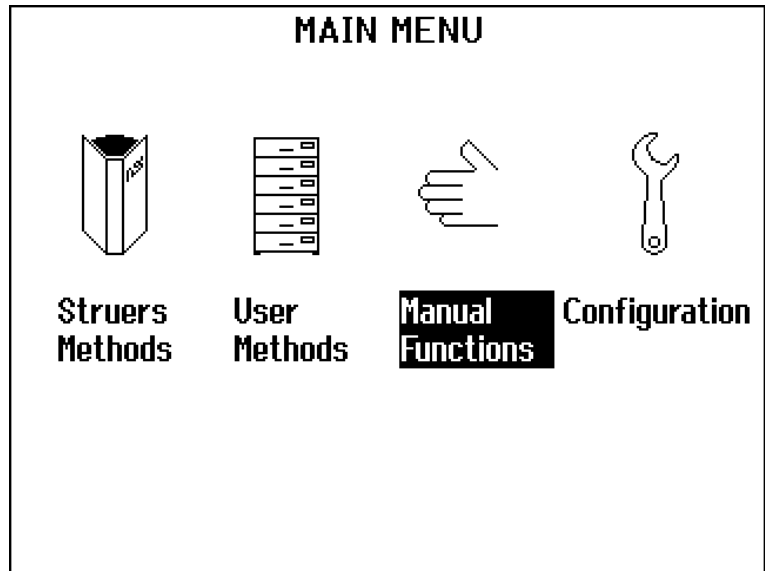

Push knob to activate the *MANUAL FUNCTIONS* menu.



Turn knob to select *Manual preparation*.

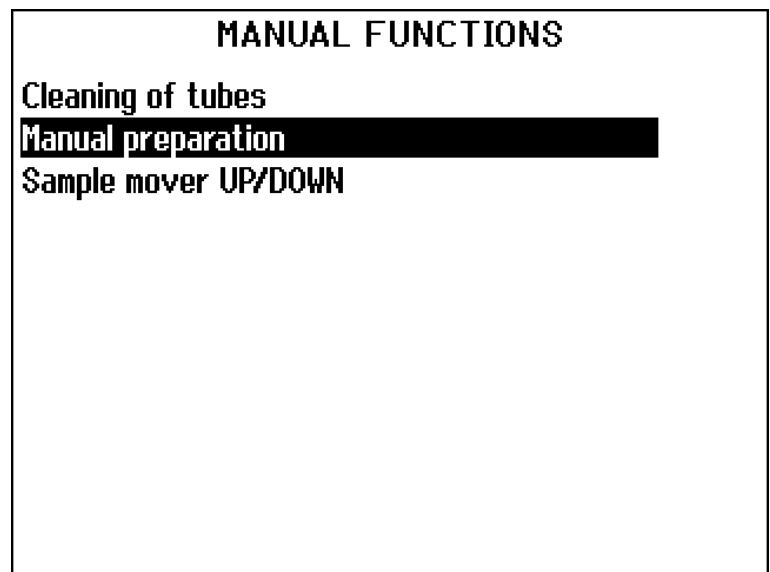

Push knob to activate the *MANUAL PREPARATION* menu.

MANUAL PREPARATION	
Disc speed [rpm]:	<b>150</b>
Suspension: DiaP.All/La	Level: 8
Lubricant: None	Level: 0

**Press START to start manual preparation.**  
**Press STOP to stop manual preparation.**



Press Start.

The preparation disc will start rotating at the pre-set speed and the selected suspension/lubricant will automatically be added in the pre-set level.



Press Stop.

The preparation disc will stop rotating and dosing will stop.

### 3. Maintenance

#### General Cleaning

The machine and the Recirculation Cooling System should be kept as clean as possible in order to avoid contamination of the specimens.

#### Cooling Tank

Each time the water is changed, the cooling tank should be cleaned carefully to remove all grinding waste.

**IMPORTANT**

Always maintain the correct concentration of Struers Additive in the cooling water (percentage stated on the container of the Additive). Remember to add Struers Additive each time you refill with water.

**IMPORTANT**

Do not use benzene or petroleum for cleaning when the additive is used.

#### Painted Surfaces

Painted surfaces and keyboard should be cleaned with a moist cloth and common household detergents.

**IMPORTANT**

Never use alcohol, acetone or similar solvents.

#### Weekly Service

##### Checking the Recirculation Cooling Unit

The cooling unit should be checked for cooling water after 8 hours use or at least every week. The unit must be refilled if the flushing pump cannot reach the cooling water or if the cooling water is too contaminated.

Please refer to the manual for the Recirculation Cooling Unit for details.

#### Monthly service

##### Replacing the Cooling Water

- Replace the cooling water in the Recirculation Cooling Unit at least once a month. Please refer to the manual for the Recirculation Cooling Unit for details.

### Cleaning of Tubes

The cleaning procedure for CLEANING OF TUBES can be used weekly or when necessary. Clean the tubes every time bottles are changed or replaced, thus avoiding lubricant/suspension left in tubes interfering with the preparation procedures.



Push knob to select *Manual Functions*.

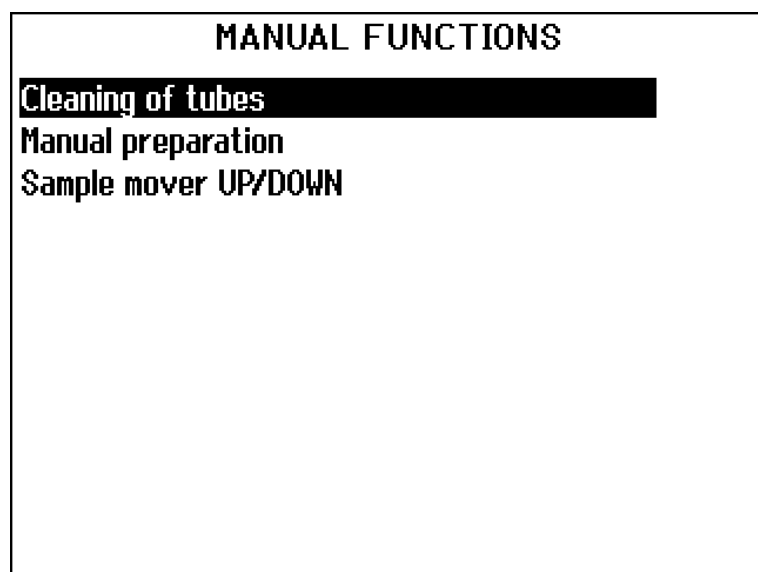
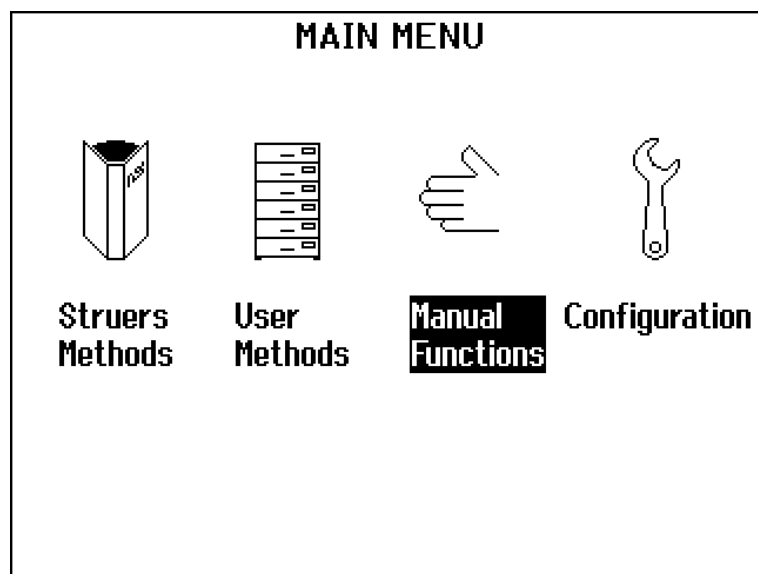

Push knob to activate *Cleaning of tubes*.

Cleaning of Selected Tubes

 Turn knob to select a bottle.

CLEANING OF TUBES			
No.	Lub./Susp name	Status	Select
1	DiaP.All	Used	No
2	DiaP.Dac	Used	No
3	DiaDuo 6µm	Clean	No
4	OP-S	Used	No
5	DPP 9µm	Clean	No
6	DP-Blue	Clean	No

**F1** / Start cleaning of selected tubes      **F2** / Select all tubes with Status = Used

↓

 Push knob to toggle between YES and NO in the Select column. One or more bottles can be selected.

↓

Select YES and press **F1**, the cleaning process starts. After a while a pop-up message will appear.

Follow the instructions in the pop-up message.

CLEANING OF TUBES			
No.	Lub./Susp name	Status	Select
1	MESSAGE		#103
2	The selected tubes are empty, disconnect		
3	the tubes from the bottles, and place the		
4	tubes in a bowl filled with water.		
5	Press <b>↵</b> when you are ready.		
6			

**ESC** / Cancel      **↵** / Continue

**F1** / Stop cleaning

↓

When tube cleaning is finished the following pop-up message appears.

CLEANING OF TUBES			
No.	Lub./Susp name	Status	Select
1			#104
2			
3			
4			
5			
6			

**MESSAGE**

Tube cleaning is finished, remove the tubes from the bowl, and connect to the bottles again.

Press **↵** when the job is done.

**↵** Ok

**F1** Stop cleaning

Cleaning of All Used Tubes

The tubes in use should be cleaned from time to time.

**F2** When in the *CLEANING OF TUBES* menu press **F2** to select all used tubes.

↓

CLEANING OF TUBES			
No.	Lub./Susp name	Status	Select
1	DiaP.All	Used	<b>Yes</b>
2	DiaP.Dac	Used	Yes
3	DiaDuo 6µm	Clean	No
4	OP-S	Used	Yes
5	DPP 9µm	Clean	No
6	DP-Blue	Clean	No

↓

**F1** Start cleaning of selected tubes

**F2** Select all tubes with Status = Used

**F1** Press **F1** to start the cleaning process and follow the pop-up instructions.

↓

CLEANING OF TUBES			
No.	Lub./Susp name	Status	Select
1	<b>MESSAGE</b>		#103
2	The selected tubes are empty, disconnect		
3	the tubes from the bottles, and place the		
4	tubes in a bowl filled with water.		
5	Press <b>↵</b> when you are ready.		
6			
			<b>ESC</b> Cancel <b>↵</b> Continue

↓

**F1** Stop cleaning

↓ When tube cleaning is finished the following pop-up message will appear.



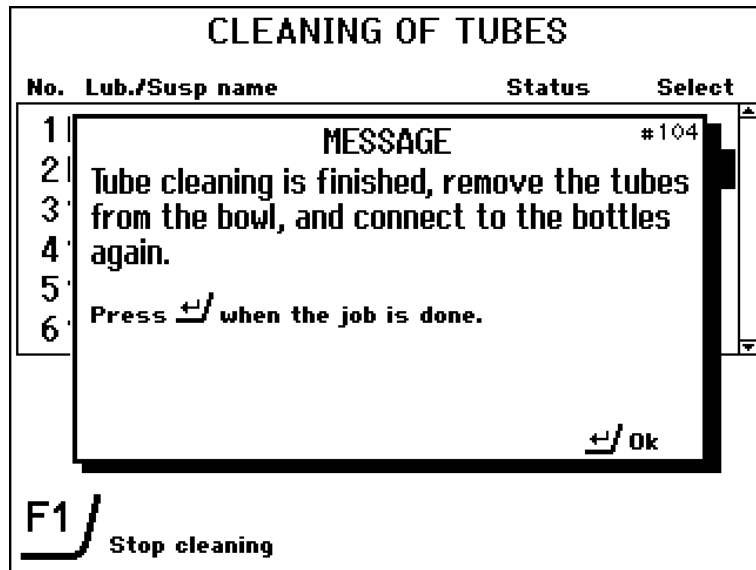

**Yearly Service**  
*Inspection of Cover*

- Visually inspect the cover and the glass for signs of wear or damage.

**Important**  
Carry out inspection at more regular intervals if AbraPol-20 is used for more than one 7 hour shift a day.

Stuers recommends that the PETG glass in the cover is replaced after 5 years of routine operation. The cover should be replaced immediately if it has been weakened by collision with projectile objects or if there are visible signs of deterioration. A label on the cover indicates when the cover glass is due to be replaced.

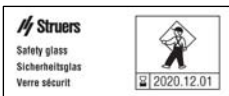

# Reference Guide

Table of Contents	Page
<b>1. Advanced Operations</b>	
Configuration Menu .....	46
Bottle Configuration .....	47
Setup User Consumables .....	47
Defining a User Surface Configuration.....	48
Defining a User Suspension Configuration .....	51
Defining a User Lubricant Configuration .....	55
Options .....	58
Operation Mode .....	60
Method Options.....	64
Struers Methods.....	64
Storing Capacity.....	64
Copying a Method.....	64
Inserting a Method .....	65
Renaming a Method.....	66
Name Editing Principles.....	67
Saving a Method.....	69
Deleting a Method.....	71
Step Options .....	72
Copying a Step .....	72
Inserting a Step.....	73
Deleting a Step .....	74
Method Parameters.....	75
Surface .....	75
Suspension .....	76
Lubricant .....	77
Level .....	77
Process Time .....	77
Removal .....	77
Force .....	77
Rotation speed.....	77
Sample holder direction .....	77
300 rpm on Sample Mover and Disc.....	78
Manual Functions.....	79
Cleaning of Tubes.....	79
Manual Preparation.....	80
Disc Speed.....	80
Suspension .....	80
Lubricant .....	81
Starting Manual Preparation .....	81
Sample mover UP/DOWN.....	81
Changing Tubes.....	82

<b>2. Accessories and Consumables</b> .....	84
Service Information .....	85
<b>3. Struers Metalog Guide™</b> .....	86
<b>4. Trouble shooting</b> .....	87
Error Messages .....	88
Messages .....	88
Errors .....	88
Fatal Errors .....	88
<b>5. Technical Data</b> .....	92
<b>6. Menu Overview</b> .....	94

## 1. Advanced Operations

### Configuration Menu

Press **Esc** until the *MAIN MENU* appears.

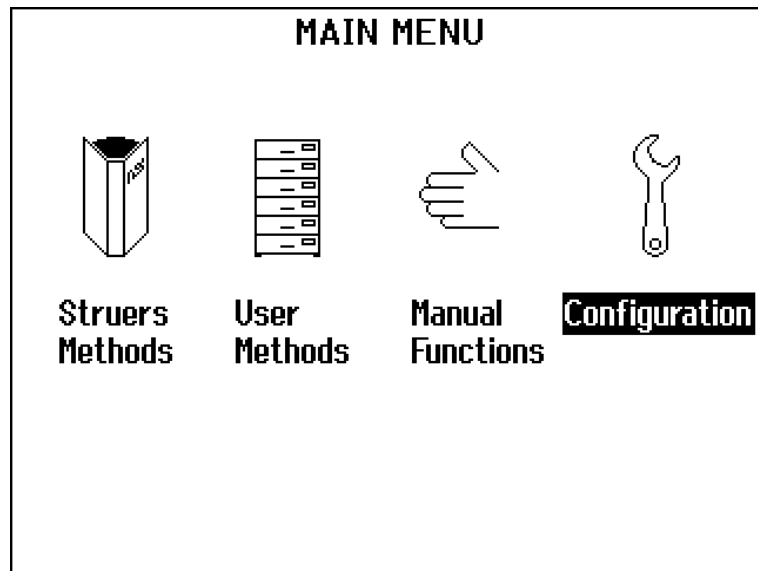

↓  
 Turn knob to select *Configuration*.

↓  
 Push knob to activate the *CONFIGURATION MENU*.

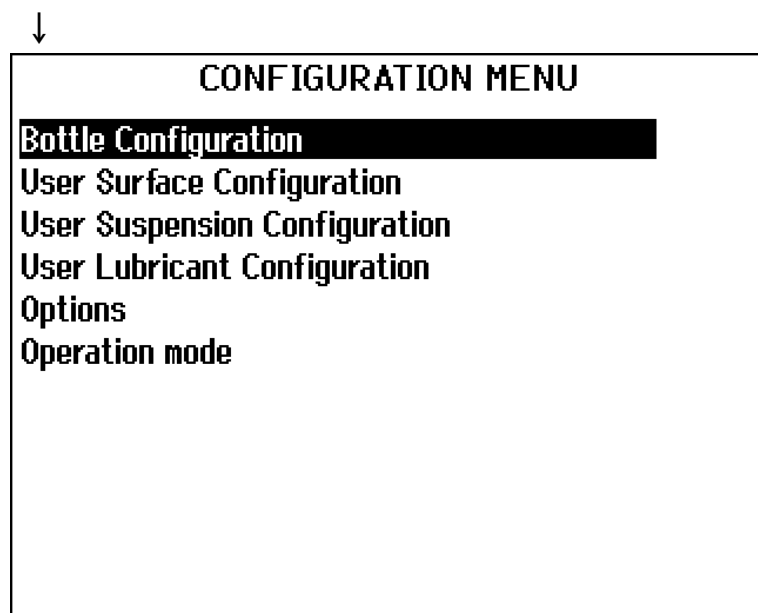

*AbraPol-20  
Instruction Manual*

*Bottle Configuration*

Please see the User's Guide section for detailed information on *Bottle Configuration*.

*Setup User Consumables*

The menus *User Surface Configuration*, *User Suspension Configuration* and *User Lubricant Configuration* allow the user to add ten grinding/polishing surfaces, ten suspensions and ten lubricants.

## **Defining a User Surface Configuration**

Using this option, it is possible to define up to 10 new user-defined surfaces. The name, the abrasive rule and lubricant rule for each surface can also be defined.

To define these parameters:

With the MAIN MENU displayed.



Turn knob to select *CONFIGURATION*.



Push knob to activate the *CONFIGURATION MENU*.

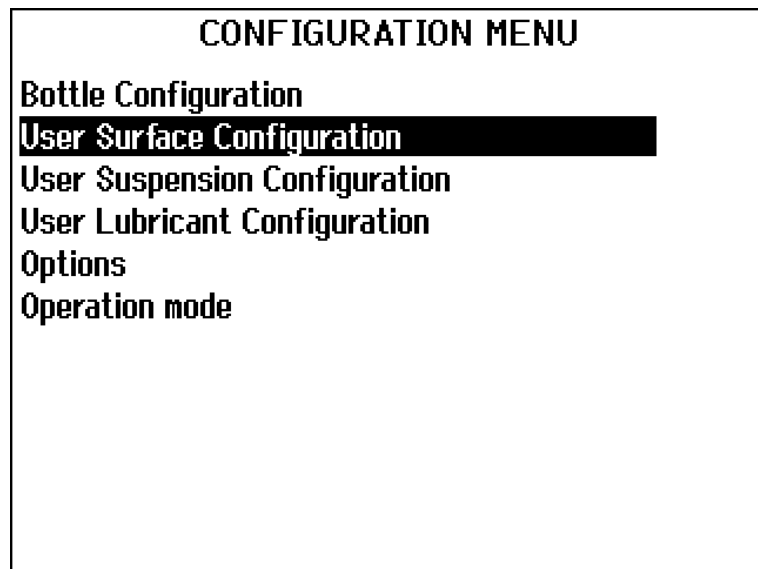

Turn knob to select *User Surface Configuration*.



Push knob to activate the *USER SURFACE CONFIGURATION* menu.



No.	Surface name	Abr. rule
1	Surf. 1, User type	1
2	Surf. 2, User type	1
3	Surf. 3, User type	1
4	Surf. 4, User type	1
5	Surf. 5, User type	1
6	Surf. 6, User type	1
7	Surf. 7, User type	1
8	Surf. 8, User type	1
9	Surf. 9, User type	1
10	Surf. 10, User type	1



Turn knob to select the *Surface name* column opposite the desired *No.* position.



Push knob to activate the Text editor and define the Surface name.



Turn knob to select the *Abr. rule* column.



Push knob to display the *SELECT ABRASIVE RULE* menu.



USER SURFACE CONFIGURATION		
No.	Surface name	Abr. rule
1	\$	1
2	\$	1
3	\$	1
4	\$	1
5	\$	1
6	\$	1
7	Surf. 7, User type	1
8	Surf. 8, User type	1
9	Surf. 9, User type	1
10	Surf. 10, User type	1



Turn knob to select the correct rule.

**Note**

It is important to select the correct rules for each surface as the selection will influence the possible choices of suspensions and lubricants available when creating a new preparation method.

If the defined surface already contains an abrasive, for example SiC paper, select 4 – no abrasives, as this means no abrasives need to be added.

If the surface is only suitable for use with diamond products, select 1.

If both oxide and diamond can be used on the surface, select 2.

If only oxide can be used, select 3.



Push knob to activate the selected rule and return to the *USER SURFACE CONFIGURATION* menu.

Repeat these steps if additional surfaces are to be configured. Otherwise follow the next step.



Press **Esc** to accept the definitions and return to the *CONFIGURATION MENU*.



## **Defining a User Suspension Configuration**

Using this option, it is possible define up to 10 new user-defined suspensions. The name, the abrasion type and lubricant rule for each suspension can then be defined.

To define these parameters:

With the *MAIN MENU* displayed.



Turn knob to select *Configuration*.



Push knob to activate the *CONFIGURATION MENU*.

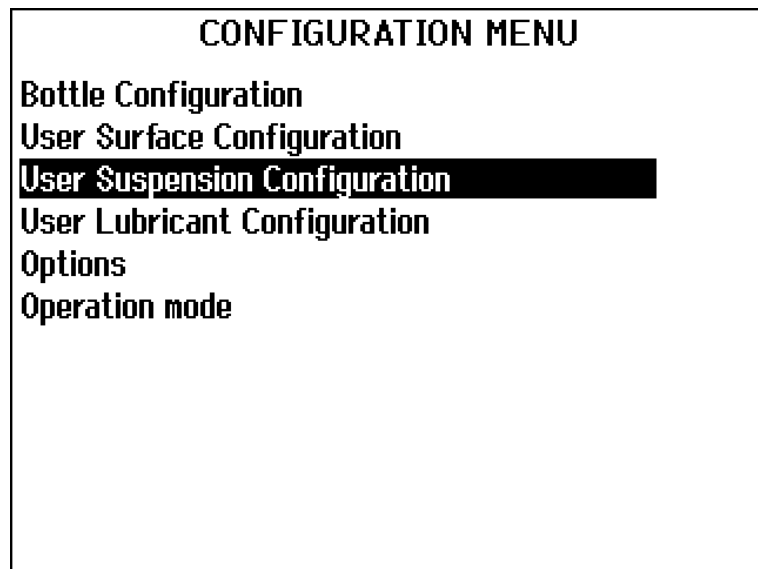

Turn knob to select *User Suspension Configuration*.



Push knob to activate the *USER SUSPENSION CONFIGURATION* menu.



No.	Susp. name	Abr. type	Lub. rule
1	Susp. 1, User type	1	1
2	Susp. 2, User type	1	1
3	Susp. 3, User type	1	1
4	Susp. 4, User type	1	1
5	Susp. 5, User type	1	1
6	Susp. 6, User type	1	1
7	Susp. 7, User type	1	1
8	Susp. 8, User type	1	1
9	Susp. 9, User type	1	1
10	Susp. 10, User type	1	1



Turn knob to select the *Susp. name* column opposite the desired *No.* position.



Push knob to activate the Text editor and define the suspension name.



Turn knob to select the *Abr. type* column.



Push knob to display the *SELECT ABRASIVE TYPE* menu.



**Note**  
There are only 2 types of abrasives available.  
Be sure to select the correct one.

USER SUSPENSION CONFIGURATION			
No.	Susp. name	Abr. type	Lub. rule
1	\$		
2	\$		
3	\$		
4	\$		
5	\$		
6	\$		
7	Susp. 7, User type	1	1
8	Susp. 8, User type	1	1
9	Susp. 9, User type	1	1
10	Susp. 10, User type	1	1



Turn knob to select the correct type.



Push knob to activate the selected type and return to the *USER SUSPENSION CONFIGURATION* menu.



Turn knob to select the *Lub. rule* column.



Push knob to display the *SELECT LUBRICANT RULE* menu.



USER SUSPENSION CONFIGURATION			
No.	Susp. name	Abr. type	Lib. rule
1	\$		
2	\$		
3	\$		
4	\$		
5	\$		
6	\$		
7	Susp. 7, User type	1	1
8	Susp. 8, User type	1	1
9	Susp. 9, User type	1	1
10	Susp. 10, User type	1	1

**SELECT LUBRICANT RULE**



**1 = Other lub. except water**

2 = No lubricant

3 = Only waterfree lubricants

**Note**

If the suspension used requires the use of a lubricant, select 1.  
If the suspension doesn't require a lubricant, e.g oxide polishing suspensions or DiaPro, select 2.  
If the abrasive is only to be used with water-free lubricants, select 3.

- ↓
-  Turn knob to select the correct rule.
- ↓
-  Push knob to activate the selected rule and return to the *USER SUSPENSION CONFIGURATION* menu.
- ↓
- Repeat these steps if additional suspensions are to be added. Otherwise follow the next step.

**Esc** Press **Esc** to accept the definitions and return to the *CONFIGURATION MENU*.

## **Defining a User Lubricant Configuration**

Using this option, it is possible to define up to 10 new user-defined lubricants. The name and lubricant type can be defined for each lubricant.

To define these parameters:

With the *MAIN MENU* displayed.



Turn knob to select *Configuration*.



Push knob to activate the *CONFIGURATION MENU*.

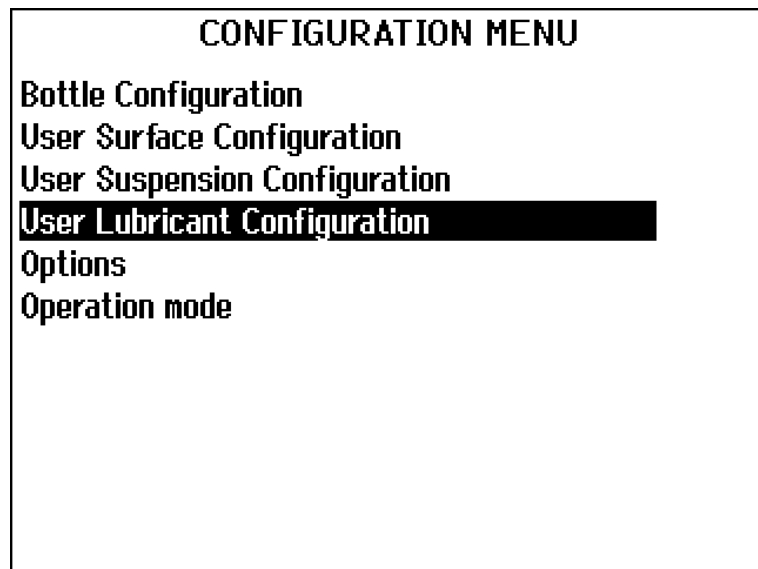

Turn knob to select *User Lubricant Configuration*.



Push knob to activate the *USER LUBRICANT CONFIGURATION* menu.



No.	Lubricant name	Lub. type
1	Lub. 1, User type	2
2	Lub. 2, User type	2
3	Lub. 3, User type	2
4	Lub. 4, User type	2
5	Lub. 5, User type	2
6	Lub. 6, User type	2
7	Lub. 7, User type	2
8	Lub. 8, User type	2
9	Lub. 9, User type	2
10	Lub. 10, User type	2



Turn knob to select the *Lubricant name* column opposite the desired *No.* position.



Push knob to activate the Text editor and define the lubricant name.



Turn knob to select the *Lub. type* column.



Push knob to display the *SELECT LUBRICANT TYPE* menu.



USER LUBRICANT CONFIGURATION		
No.	Lubricant name	Lub. type
1	L	2
2	L	2
3	L	2
4	L	2
5	L	2
6	L	2
7	Lub. 7, User type	2
8	Lub. 8, User type	2
9	Lub. 9, User type	2
10	Lub. 10, User type	2

**SELECT LUBRICANT TYPE**

1 = Lubricant containing water  
2 = Waterfree lubricant

**Note**  
If the lubricant contains water, select 1.  
If the lubricant is water-free and is to be used when preparing water-sensitive materials, select 2.



Turn knob to select the correct type.



Push knob to activate the selected type and return to the *USER LUBRICANT CONFIGURATION* menu.



Repeat these steps if additional lubricants are to be added.  
Otherwise follow the next step.



Press **Esc** to accept the definitions and return to the *CONFIGURATION MENU*.

## Options

Select *Options* and push the knob to activate the *OPTIONS* menu

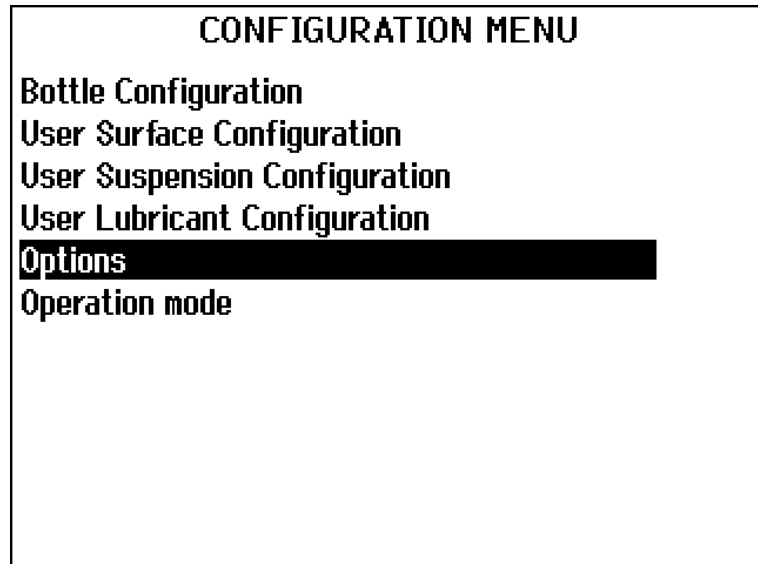

The following settings can be adjusted:

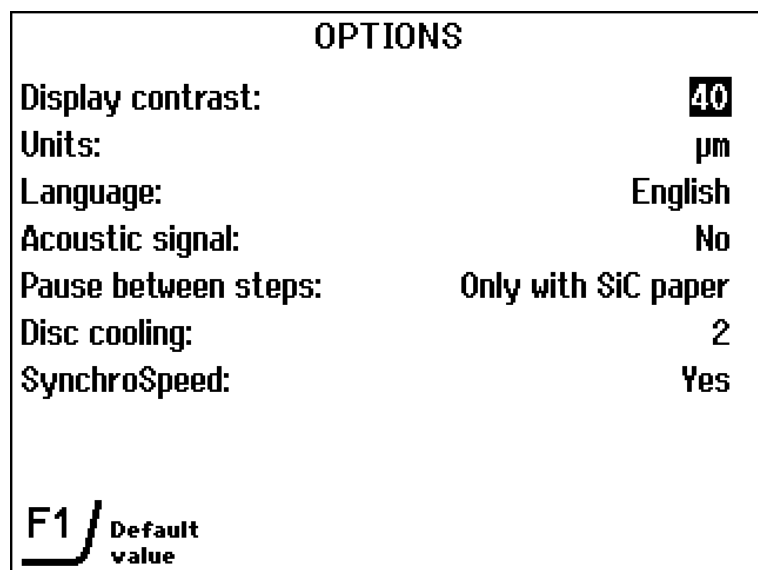



Display Contrast	The contrast settings of the display can be adjusted for maximum readability.
Units	Select between $\mu\text{m}$ or mils (mils??) for the removal rate settings.
Language	The language can be set to English, German, French, Spanish Japanese or Chinese.
Acoustic signal	Select to have each activation of a key on the touchpad confirmed by an acoustic signal.
Pause between steps	Several preparation steps can be combined to a single step with several phases. Normally steps with the same surface, suspension and lubricant will be run without interruption. Pause between steps can be used to program things differently.

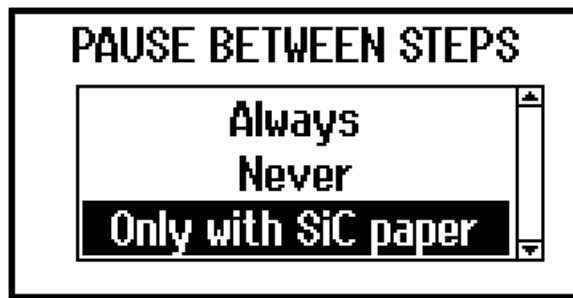

- Always:** Even if surface, suspension and lubricant are the same AbraPol-20 will stop after every step. The surface can be exchanged and the specimen holder can be re-positioned.
- Never:** All steps based on the same surface, suspension and lubricant will be run without stopping
- Only with SiC paper:** When SiC paper is selected the preparation is stopped in-between identical steps. With other surfaces the steps will be run in succession.

Disc cooling	Disc cooling can be set to levels between 0 – 5. 0 is off, 5 is running continuously. Levels 1 -4 are intermediate settings.
SynchroSpeed	When SynchroSpeed is selected changes of either the disc speed or the holder speed will automatically result in changes of the other speed as well. SynchroSpeed works only in the range of 50 – 300 rpm. For higher speed settings of the disc SynchroSpeed has to be set to: No
F1, Default Value	The factory setting of some parameters can be restored by pressing the function key <b>F1</b> when the appropriate value is highlighted.

## Operation Mode

In *Operation mode* 3 different user levels can be set.

<b>Operation Modes:</b>	
<b>Process:</b>	Methods can be selected and viewed but no editing is possible.
<b>Development:</b>	Methods can be selected, viewed and edited
<b>Configuration:</b>	Methods can be selected, viewed and edited and bottles can be configured.

To define these parameters:

With the *MAIN MENU* displayed.



Turn knob to select *Configuration*.



Push knob to activate the *CONFIGURATION MENU*.



Turn knob to select *Operation mode*.

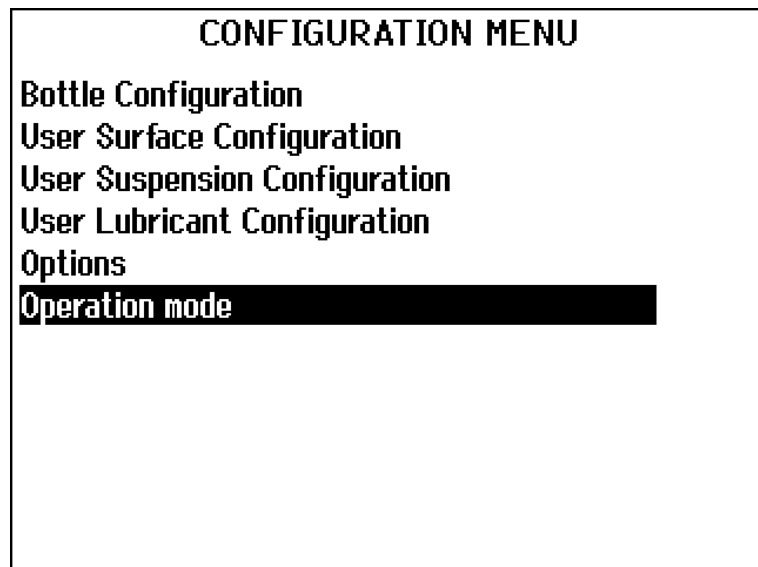

Push knob to activate the *OPERATION MODE* menu.



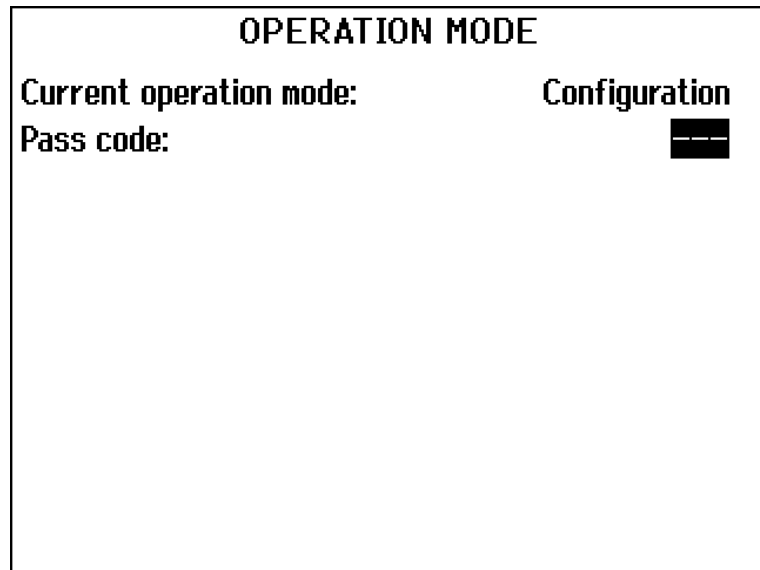

Push knob to activate the *Pass code* selector.

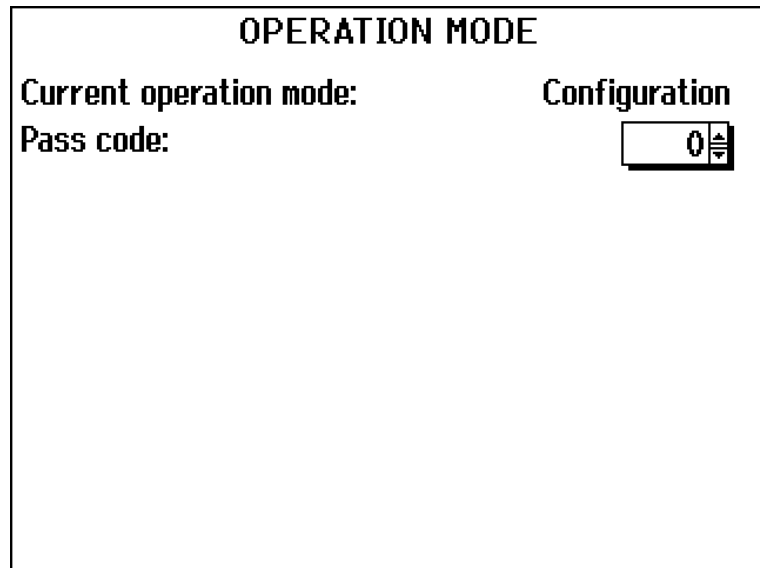

Turn knob to set the value to 176.



Push knob to enter the pass code.

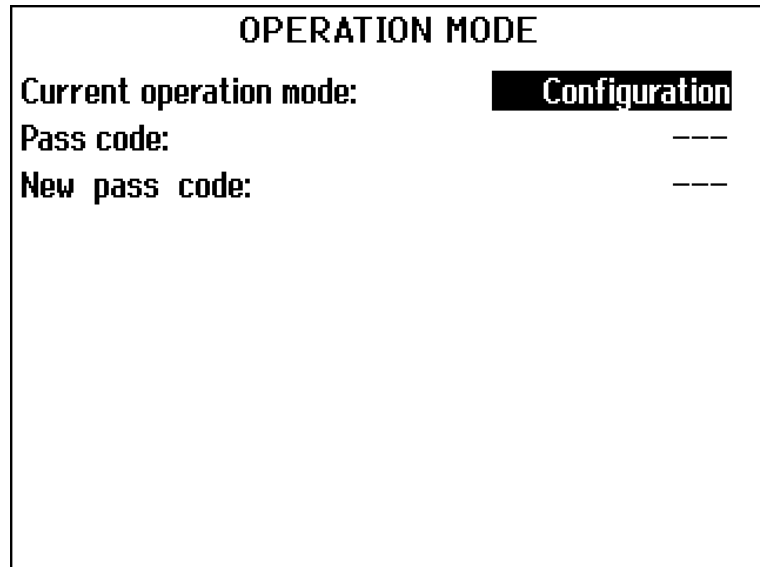

Push knob to activate the *SELECT OPERATION MODE* menu.

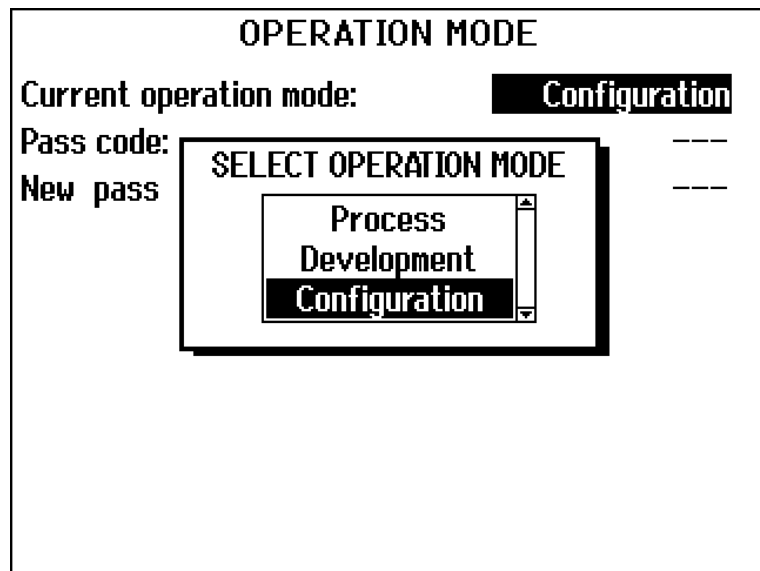

Turn knob to select the appropriate operation mode.



Push knob to enter the selection.



OPERATION MODE	
Current operation mode:	<b>Process</b>
Pass code:	---
New pass code:	---

***Important!***

Remember to make a note of the new Pass code as settings can no longer be changed without the Pass code.

## Method Options

Methods can be adjusted to suit the particular requirements of the user.

### Struers Methods

The AbraPol-20 software includes 10 Metalog Guide Methods. The AbraPol-20 will automatically calculate the correct preparation time and dosing level depending on if a 300 mm disc and 350 mm disc is used.

As the Struers methods can not be changed or deleted, the first step will often be to copy a Struers method into the User Methods database and then adjust it to suit individual requirements.

### Storing Capacity

The new/adapted methods can be stored in 10 groups; each group can contain 20 methods resulting in an overall storage capacity of 200 methods.

### Copying a Method

In the Main Menu select STRUERS METHODS.

↓  
 Push knob to activate the STRUERS METHODS menu

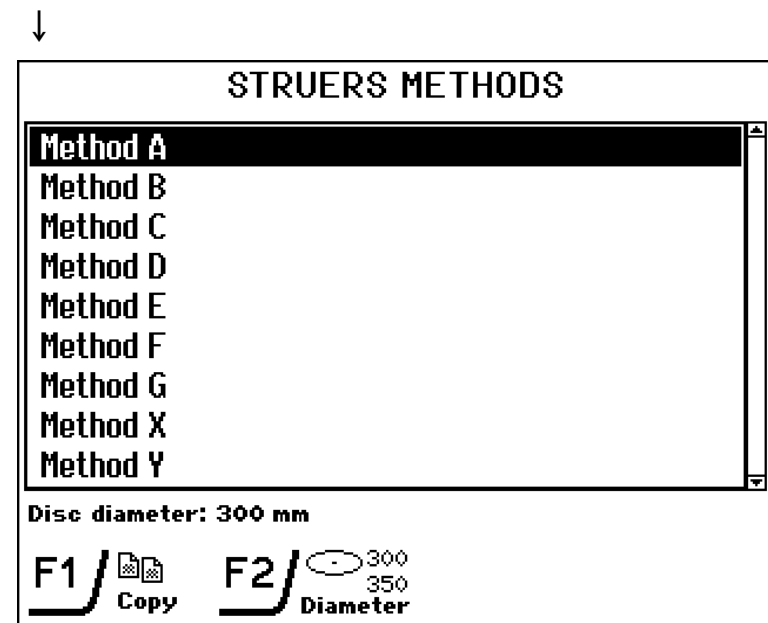

↓  
 Select the correct method and press F1: COPY.

*Inserting a Method*

**Esc** Press Esc to return to the Main Menu.

↓  
In the Main Menu select  
USER METHODS.

**F2** Press **F2** to insert the copied method.

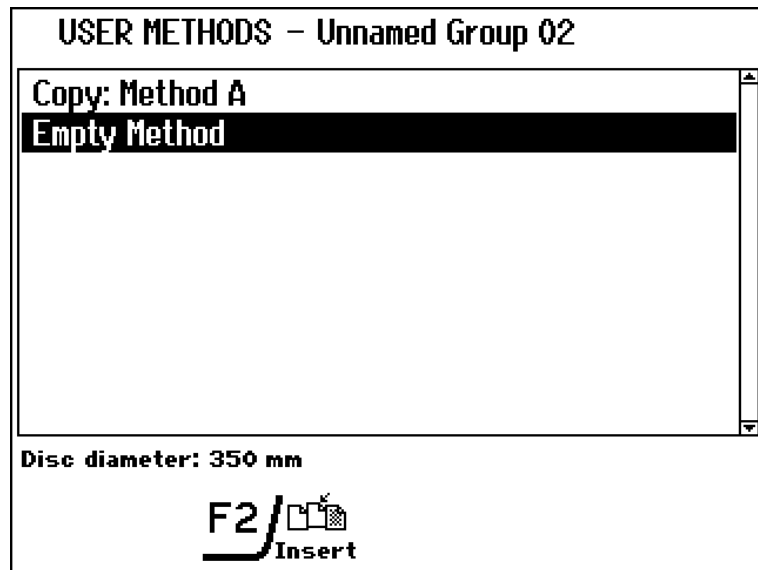

### Renaming a Method

The names of the methods in the USER METHODS database can be edited and changed. After copying a method from the Struers Methods the name can be changed to a name of your choice.

Select the method you want to rename.

↓  
**F4** Press F4: RENAME.

The following screen will appear:

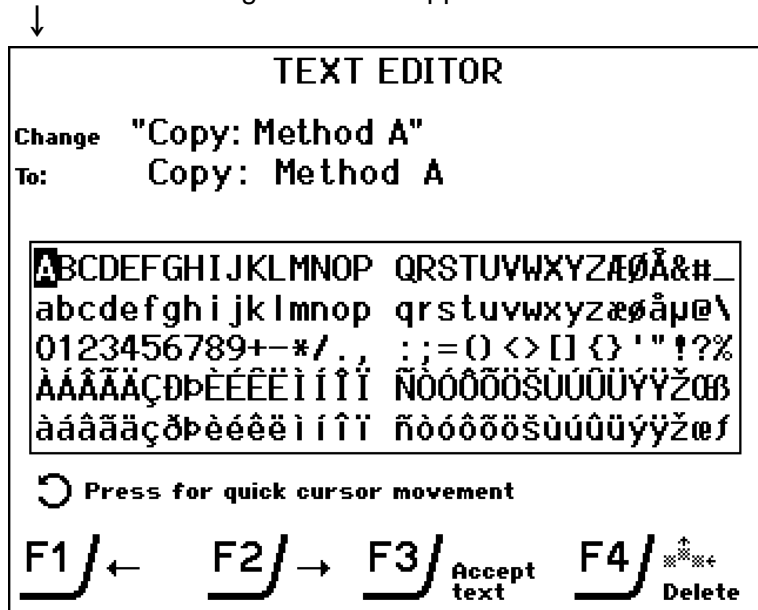

Use F1 or F2 to select the character to be changed.

↓ Use F4 to delete the selected character.

↻ Turn knob to move the cursor in the character set.

↓ Push knob to insert new character.

↓ For detailed information please see "Name Editing Principles".



**NB!**  
If a method name starts with "Copy of ....." the text "Copy of" can be deleted by pressing F4 once.



Name Editing Principles

Place the auxiliary cursor on the character you want to select, using **F1**: LEFT or **F2**: RIGHT. Turn the knob to move to the character cursor to select a character.

■ Write the new name using the following keys:

- F1** Moves the cursor to the left
- F2** Moves the cursor to the right
- F3** Accepts the new name
- F4** Deletes one character in the text
-  Moves character cursor when turned.
-  Enters characters (from character set) when pressed. Pressing the disc button moves the cursor to the next line

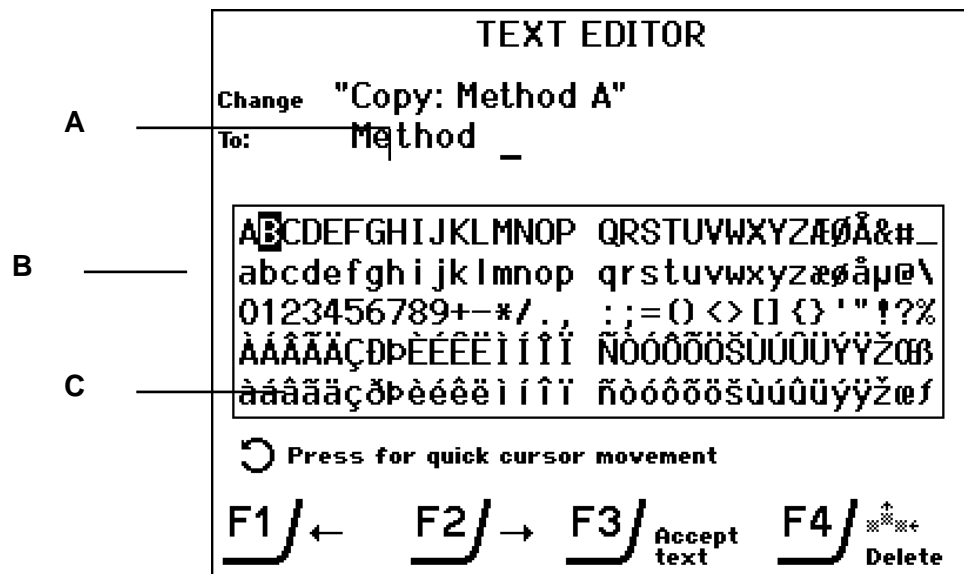

- A Auxiliary cursor
- B Character cursor
- C Character set

Write the new name using the name editing procedures.

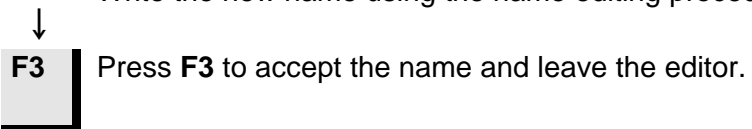

Press **F3** to accept the name and leave the editor.

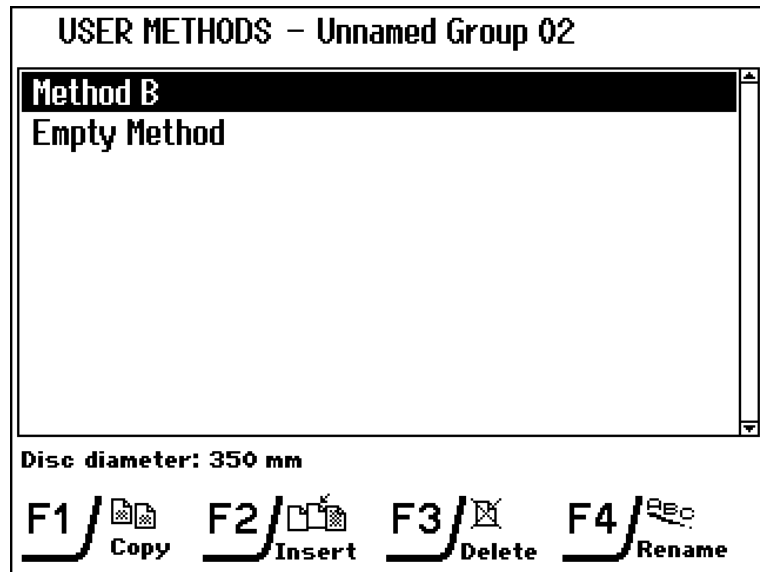

*Saving a Method*

While working with a user method, changes made in the database can be saved.

- As soon as a parameter is changed, **F4: SAVE** will be shown on the display and changes can be saved.  
 Changes can be saved at both step and method level.

**EDIT METHOD STEP – Step No 1**

Surface: SiC-Paper #320  
 Lubricant: Water  
 Process Time: 1 m 00 s  
 Force: **180N**  
 Rotation speed (disc / holder): 300/300 rpm  
 Sample holder direction: ↻  
 Process mode: Time

Disc diameter: 350 mm

F1 / ↶  
 Prev.

F2 / ↷  
 Next

F4 / 📄  
 Save

**EDIT METHOD – Method A**

	Surface	Susp.	Lub.	µm or Time
1	SiC-Pap #320		Water	1m 00s
2	Largo	All/La		3m 00s
3	Mol	Mol		2m 00s
4	MD-Chem	OP-S		1m 00s
5	Empty Step			

Process mode: Time

Disc diameter: 350 mm

F1 / 📄  
 Copy

F3 / ✖  
 Delete

F4 / 📄  
 Save

↓  
**F4** Press **F4: SAVE** to save the changes after all necessary parameters have been altered.

***Important***

When saving changes, the original method will be overwritten. To preserve the original method, a copy should be made and renamed. The new method can then be changed as required.

For details, see *Copying a Method*.

If a new method is created from EMPTY METHOD the name will automatically change name from Empty Method to Unnamed Method 01 when saved.

The method can then be renamed and altered as required.

A new empty method is always created automatically.

### Deleting a Method

If a method is no longer used it can be deleted.

Select the method you want to delete.

↓  
**F3** Press **F3:DELETE**.

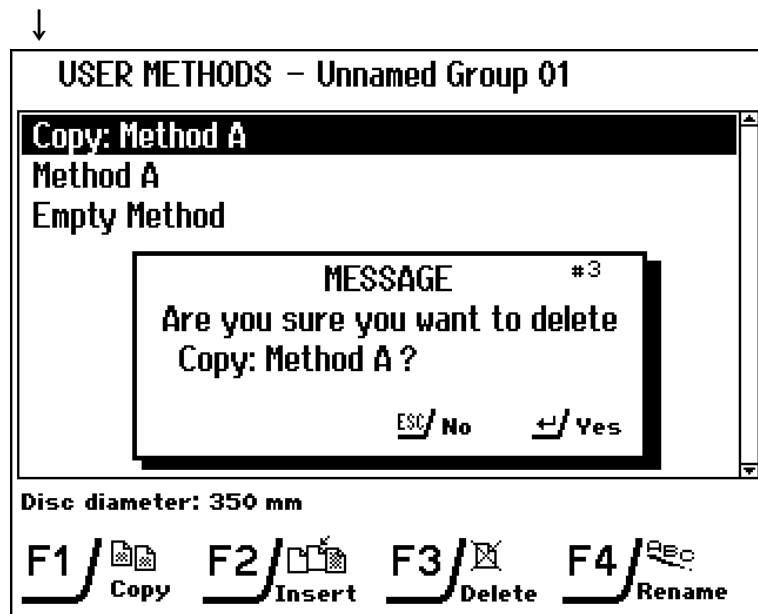

↓ When asked for confirmation,

 Push knob to confirm

**NB!**  
Struers Methods can not be deleted.

## Step Options

### Copying a Step



Single steps can also be copied to customise preparation methods.

Select the method and the preparation step to be copied.

EDIT METHOD – Method A			
	Surface	Susp.	Lub. $\mu\text{m}$ or Time
1	SiC-Pap #320		Water      1m 00s
2	Largo	All/La	3m 00s
3	Mol	Mol	2m 00s
4	MD-Chem	OP-S	1m 00s
5	Empty Step		

Process mode: \_\_\_\_\_ Time \_\_\_\_\_

Disc diameter: 350 mm

**F1** /  Copy      **F3** /  Delete

**F1**

Press F1: Copy.

The method step is automatically copied into the buffer





Inserting a Step

EDIT METHOD – Method A			
	Surface	Susp.	Lub.      µm or Time
1	SiC-Pap #320		Water      1m 00s
2	Largo	All/La	3m 00s
3	Mol	Mol	2m 00s
4	MD-Chem	OP-S	1m 00s
5	Empty Step		

Process mode: \_\_\_\_\_ Time \_\_\_\_\_

Disc diameter: 350 mm

F1 /  Copy    F2 /  Insert    F3 /  Delete

↓ Select the method and step where the copied step is to be inserted.





**F2** Press F2: Insert.  
The step is automatically inserted after the step shown inverted

↓

EDIT METHOD – Method A			
	Surface	Susp.	Lub.      µm or Time
1	SiC-Pap #320		Water      1m 00s
2	Largo	All/La	3m 00s
3	Largo	All/La	3m 00s
4	Mol	Mol	2m 00s
5	MD-Chem	OP-S	1m 00s
6	Empty Step		

Process mode: \_\_\_\_\_ Time \_\_\_\_\_

Disc diameter: 350 mm

F1 /  Copy    F2 /  Insert    F3 /  Delete    F4 /  Save

↓

**F4** Press F4: Save.  
The changed method is saved.

Deleting a Step



Turn knob to move to step you want to delete.



**F3**

Press **F3** Delete.  
A pop-up will appear.

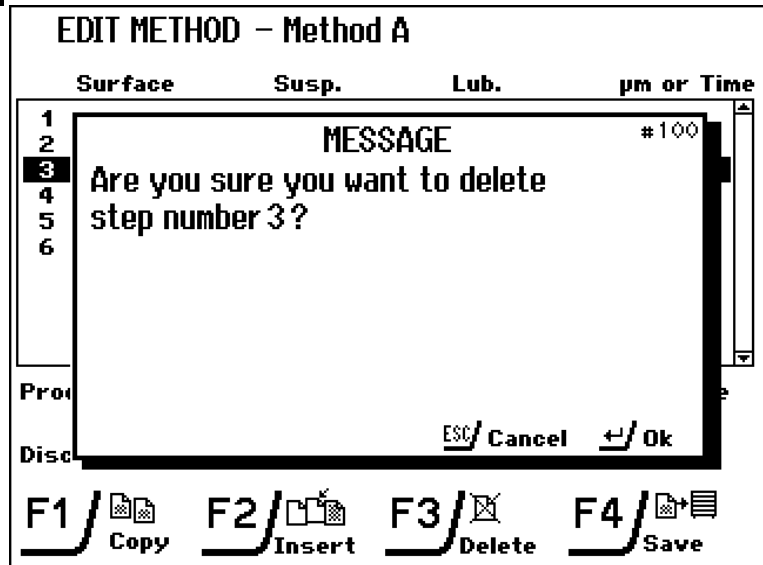

When asked for confirmation,



Push knob to confirm



**F4**

Press **F4** Save  
To save the changed method.



**Method Parameters**

For every method step a series of parameters can be changed:

**EDIT METHOD – Method A**

	Surface	Susp.	Lub.	µm or Time
1	SiC-Pap #320		Water	1m 00s
2	Largo	All/La		3m 00s
3	Mol	Mol		2m 00s
4	MD-Chem	OP-S		1m 00s
5	Empty Step			

Process mode: \_\_\_\_\_ Time \_\_\_\_\_

Disc diameter: 350 mm

F1 / Copy    F2 / Insert    F3 / Delete    F4 / Save

*Surface*

Pushing the knob allows you to select between all the surfaces in the AbraPol-20 database:

**EDIT METHOD STEP – Step No 2**

Surface: MD-Largo

Suspension: \_\_\_\_\_

Process: \_\_\_\_\_

Force: \_\_\_\_\_

Rotation: \_\_\_\_\_

Sample: \_\_\_\_\_

Process: \_\_\_\_\_

**SELECT SURFACE TYPE**

MD-products

DP/OP-products

SP-products

PG/SiC-paper

Other products

2 / 8

3 m 00 s

240 N

50 rpm

Time \_\_\_\_\_

Disc diameter: 350 mm

F1 / Prev.    F2 / Next    F4 / Save

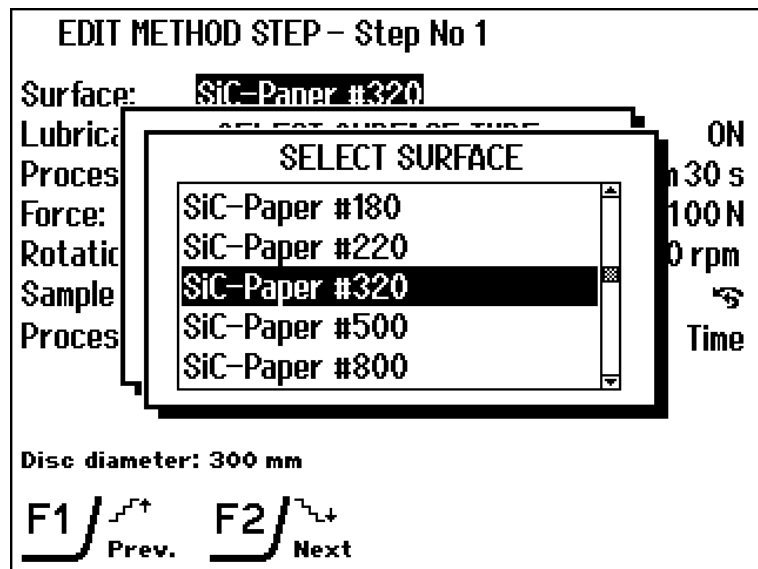

*Suspension*

Depending on the surface selected a variety of different suspensions can be chosen.

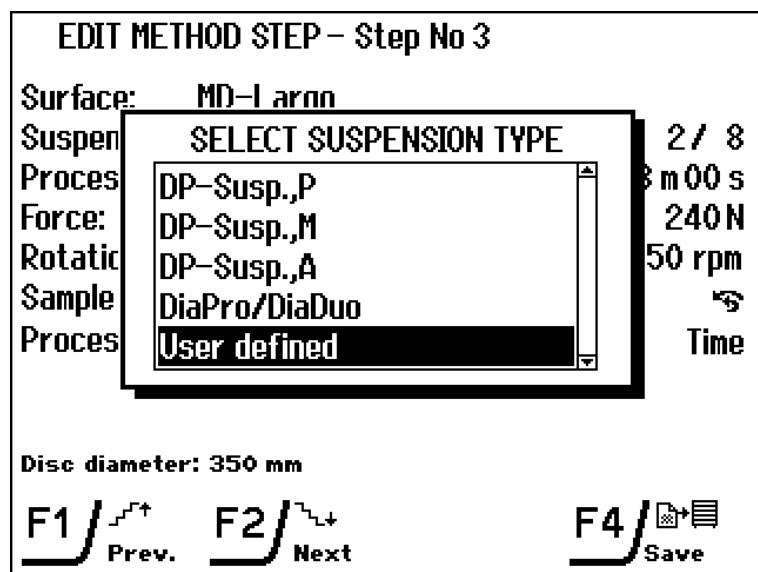

*Lubricant*

Depending on the selected suspension it may be possible to select a lubricant.

If DiaPro or DiaDuo, an all-in-one suspension has been selected the line Lubricant disappears completely.

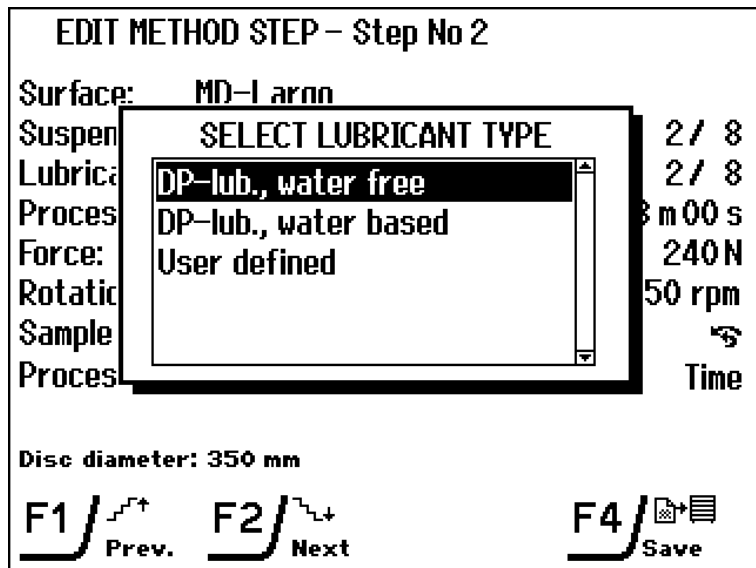

*Level*

The dosing level can be set. The first number is the pre-dosing time in seconds. It can be set between 0-10  
The second number is the dosing level that can be adjusted between 0-20

*Process Time*

When Time is selected in Process mode the preparation time can be adjusted between 5 seconds and 60 minutes.

*Removal*

When Removal is selected in Process Mode, the amount of material to be removed can be adjusted between 50 – 2000 µm.  
(The removal rate sensor is an accessory)

*Force*

The force can be adjusted between 50 and 700 Newton.

*Rotation speed*

The speed of the disc can be set between 50 – 500 rpm. When SynchroSpeed is set to Yes the max. setting is 300 rpm.  
The speed of the holder can be set between 50 – 300 rpm.

*Sample holder direction*

The direction can be set to either co- or counter-rotation.  
Co-rotation will give the best preparation result and the most uniform polishing. Counter-rotation can be used when polishing using oxide polishing suspensions to keep the suspension on the polishing cloth.

*300 rpm on Sample Mover  
and Disc*

When using 300 rpm on the sample mover and 300 rpm on the disc please note the following recommendations:

- Use disc cooling.
- Pre-dose sufficiently when working with new preparation surfaces.
- Use a 200 mm sample holder on a 350 mm surface to distribute the lubricant and abrasive adequately.
- Use DP-Lubricant, Green or DP-Lubricant, Red. DP-Lubricant, Blue is alcohol-based and will evaporate too quickly.

## Manual Functions

Several manual functions are included in the software of AbraPol-20. Press Esc until you reach the Main Menu.



Push knob to select MANUAL FUNCTIONS.

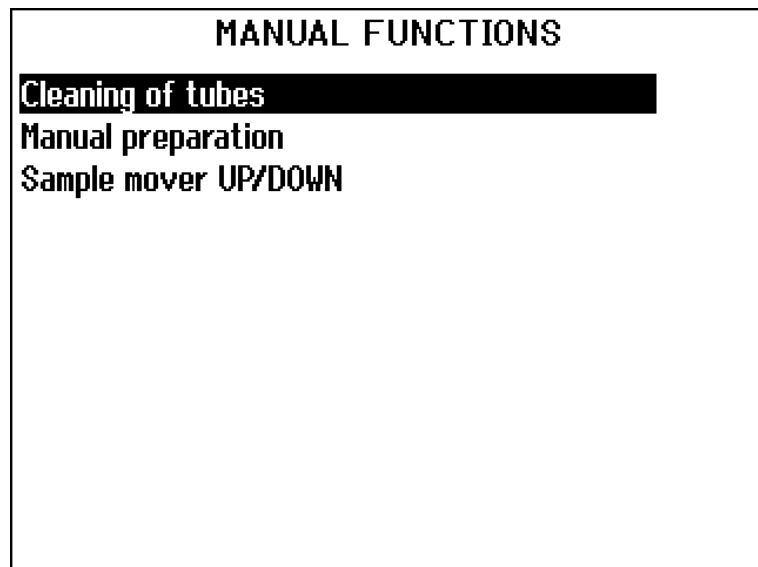
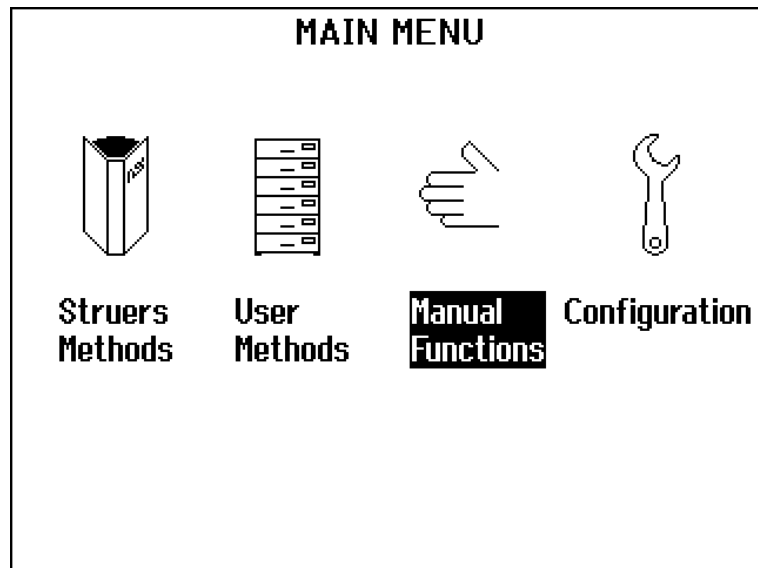

### *Cleaning of Tubes*

Cleaning of tubes is described in depth earlier in the manual in section 3 Maintenance.

*Manual Preparation*

Manual functions are possible as the disc can run independently of the specimen holder.

MANUAL PREPARATION	
Disc speed [rpm]:	<b>150</b>
Suspension: None	Level: 0
Lubricant: None	Level: 0

Press **START** to start manual preparation.  
Press **STOP** to stop manual preparation.

*Disc Speed*

The speed can be set between 50 and 300 rpm. in steps of 10 rpm.

*Suspension*

The different suspensions that are configured in the bottle set-up can be selected here.

MANUAL PREPARATION	
Disc speed [rpm]:	150
Suspension: All/La	Level: <b>8</b>
Lubricant: None	Level: 0

Press **START** to start manual preparation.  
Press **STOP** to stop manual preparation.

*Dosing Level*

The dosing level can be set to a value between 0 and 20.

*Lubricant*

A lubricant can be selected together with a diamond suspension for manual preparation. Only lubricants that are configured in the bottle set-up can be selected.

MANUAL PREPARATION	
Disc speed [rpm]:	150
Suspension: DP-Suspension,P 9µm	Level: 5
Lubricant: DP-Lubricant,Blue	Level: <b>8</b>

**Press START to start manual preparation.**  
**Press STOP to stop manual preparation.**

*Dosing Level*

The dosing level can be set to a value between 0 and 20.

*Starting Manual Preparation*

After defining all parameters the manual preparation can be started by pressing **Start**.

**NB!**  
If no suspension or lubricant is selected or the dosing levels are set to 0 the manual preparation can not be started.

*Sample mover UP/DOWN*

This function is described earlier in the manual in the section [Adjusting the Specimen Holder Position](#).

*Adjusting the Speed of the Sample Mover Head*

The speed at which the Sample Mover head moves up and down can be adjusted by turning the adjustment screw using a screwdriver:

- Increase speed: turn the screw head Counter-clockwise
- Reduce speed: turn the screw head Clockwise

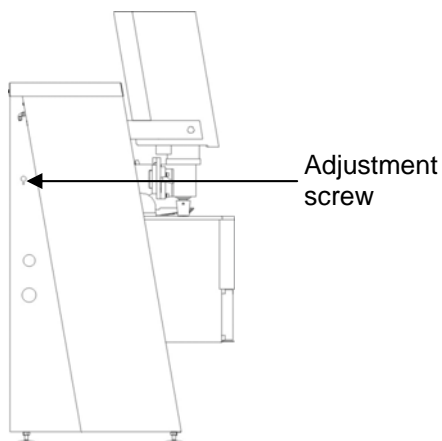

**Tip!**  
Take care not to set the speed too high, this could result in damage to the samples or the grinding/polishing consumable.

## Changing Tubes

When working with alcohol based lubricants, the Novoprene tubes mounted in the pumps supplied with AbraPol-20 will harden over time. Therefore a piece of silicone tubing is supplied with the AbraPol-20 as Silicone has a better resistance against alcohol.

To exchange the Novoprene tube with a Silicone tube:

- Separate the doser tubes at the couplings.
- Press the two tabs and remove the pump from the axle.

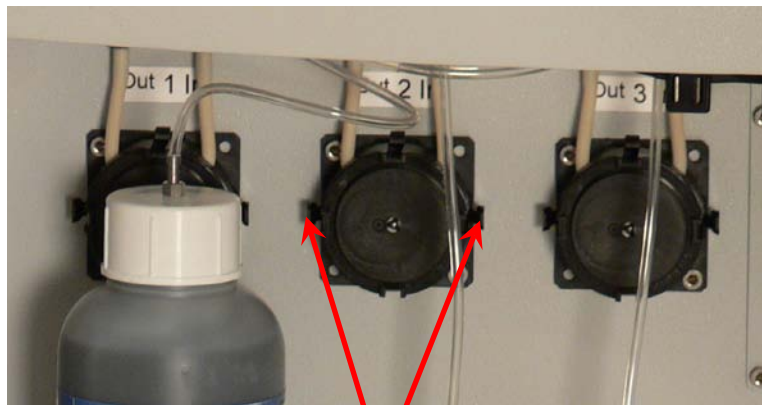

Tabs

- Press the two tabs on the pump and remove the bottom cover.

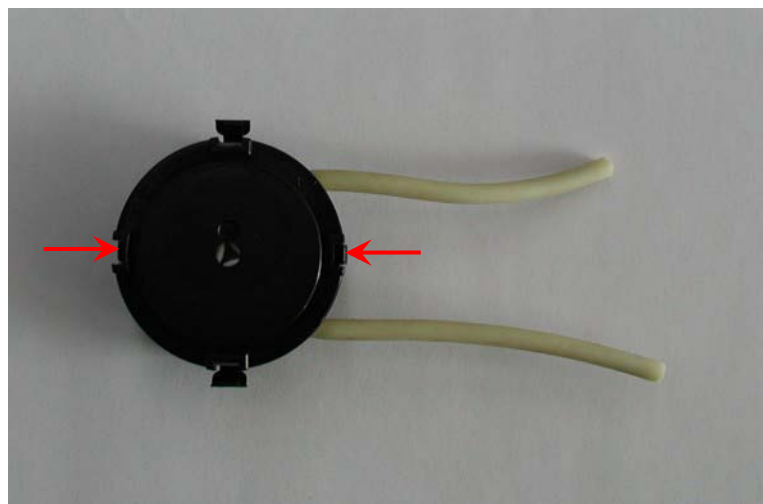



- Remove the 3 loose rollers and replace the Novoprene tube with the silicon tube.



- Replace the 3 rollers in the pump housing.



- Re-mount the bottom cover.
- Re-connect the tubes to the tubes on the AbraPol-20 and press the pump back onto the axle.
- Check that the tubes are connected correctly so that liquid is pumped to the head.

## **2. Accessories and Consumables**

Please refer to the [AbraPol-20 Brochure](#) and the [Consumables Catalogue](#) for details of the range available.

***Remember...***

Struers offers a comprehensive range of consumables for grinding and polishing.

**Service Information**

Struers recommends that a regular service check be carried out after every 1500 hours of use. Information on total operation time and servicing of the machine is displayed on the screen at start-up:

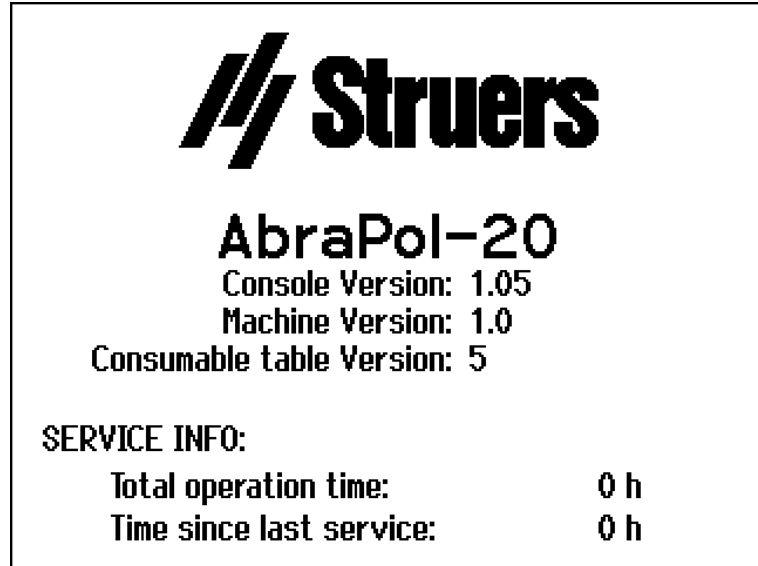

- Contact a Struers Service Technician to service the machine.

### **3. Struers Metalog Guide™**

In Struers Metalog Guide™ you will find a detailed description of grinding/polishing methods for automated mechanical specimen preparation.

Struers Metalog Guide™ offers preparation methods for the most common materials, based on a simple analysis of two key properties: hardness and ductility. Finding the right method is easy, including choice of consumables. Always consult Struers Metalog Guide™ for the correct preparation method for the actual specimens.

**Metalog Guide™**

A complete guide to materialographic specimen preparation.  
[www.struers.com/KNOWLEDGE/Metalog\\_Guide](http://www.struers.com/KNOWLEDGE/Metalog_Guide).

## 4. Trouble shooting

<b>Error</b>	<b>Explanation</b>	<b>Action</b>
<b>Machine Problems</b>		
AbraPol-20 is switched on but the display is difficult to read	The backlight of the display has been dimmed. AbraPol-20 is in Sleep Mode.	Press any key to re-activate the backlight.
Display text not clear	The display is sensitive to temperature changes.	Change the display contrast in the CONFIGURATION Menu.
Display defective	Defect in the circuit of the display or defect in the CPU circuit.	Please contact a Struers Service Technician.
Water not draining away.	Drain hose squeezed.	Straighten the hose.
	Drain hose clogged.	Clean the hose.
	Drain hose does not slope downward.	Adjust the hose to an even slope.
Continuous, irregular wear on a grinding/polishing surface.	Coupling on either the specimen holder/mover plate or the specimen mover head of the polishing machine is worn.	Please contact a Struers Service Technician to replace the coupling.

## **Error Messages**

Error messages are divided into three classes:  
Messages  
Errors  
Fatal Errors

### *Messages*

Messages are intended to inform the operator of the machine's progress and advise about minor operational errors.

### *Errors*

Errors must be rectified before process can continue.

### *Fatal Errors*

In case of Fatal Errors, process cannot continue before an authorised technician has rectified the error. Turn off the unit at the main switch immediately. Do not attempt to operate unit before technician has rectified problem.

<b>Message</b>	<b>Explanation</b>	<b>Action</b>
Process in Progress	Start is not possible as other process in progress.	
Process already stopping	Appears if Stop is pressed repeatedly.	
Process is stopping	Stop has been pressed.	
Process is stopping, await flushing please	The process is stopping but flushing removes residues of OP-Suspensions.	Wait until the flushing is completed.
Emergency Stop is active	The emergency button was pressed and the preparation was interrupted.	Pull the button outwards to release it and follow the instructions in the pop-up text.
Database is full !	The database storing capacity has been reached.	Delete one or more of the methods – this will free space to store new methods.  Nb! it is not possible to delete Struers Methods.
10 steps is maximum !	The maximum of 10 steps has been reached.	Two or more methods can be used alternately.
Process is finished	The process is finished.	You can now start another process.

*AbraPol-20  
Instruction Manual*

<b>Message</b>	<b>Explanation</b>	<b>Action</b>
START denied method not selected	A method has not been select.	Select a method and press start.
Manual dosing denied method step not selected	Manual dosing has been denied because step has not been selected.	Choose a preparation step that contains the suspension or lubricant in question.
The following lubricant is not configured: " xx "	The lubricant chosen for a certain preparation has not been configured and the preparation can not proceed.	In the CONFIGURATION MENU it is possible change the set-op for the different lubricants. (See Setup Bottle Configuration)
You can not dose with water	The manual lubricant key has been pressed in a step where water was selected.	Use the  key for manual dosing of water.
Process time or stock removal not specified (zero)	The step can not start because neither time nor removal have been specified.	In EDIT METOD STEP specify time or stock removal.
START denied, selected method or step is Empty	It is not possible to start a preparation process from an empty method or step.	Chose a method or a step which is not empty before pressing start.
Tube(s) not selected for cleaning push knob to select tube(s)"	The tube has not been selected and can therefore not be cleaned.	Push knob to toggle between yes and no in the select column – yes must be selected if you want to clean the tube.
The following abrasive is not configured: " xx "	The abrasive chosen for a certain preparation has not been configured and the preparation can not proceed.	In the CONFIGURATION MENU it is possible change the set-op for the different abrasives. (See Setup Bottle Configuration)
Method name already in use, please rename the method	A method name can only be used once.	Use a different name.

*AbraPol-20*  
*Instruction Manual*

<b>Message</b>	<b>Explanation</b>	<b>Action</b>
Disc motor overloaded	The disc motor was overloaded and therefore overheated.	Wait till the motor has cooled off and reduce the force before restarting the process.
Sample motor overloaded	The sample motor was overloaded and therefore overheated.	Wait till the motor has cooled off and reduce the force before restarting the process.
Pump motor overloaded	Water hose blocked or too much swarf in coolant.	Replace coolant. Inspect pump.
Main supply voltage too low	Supply voltage insufficient.	Await normalisation of power grid.
Removal rate too low, phase time exceeded	It has not been possible to grind/polish the samples to the expected level within 15 minutes.	Select a different surface or/and increase the force.
Sample holder unable to move, upwards after process	It was not possible to move the sample holder upwards after finishing a process.	The pressure in the compressed air system is too low.
		Force regulation error – please contact a Struers Service Technician.
Force regulation error	It is not possible to reach the selected force.	The pressure in the compressed air system is too low.
		Force regulation error – please contact a Struers Service Technician.
Air pressure too low	Missing or incomplete air supply.	Check that the air hoses are tight and properly clamped.
Stock removal sensor not installed	Stock removal sensor has not been installed or has not been calibrated.	If stock removal sensor (accessory) is not installed this must be done before the stock removal mode can be used.
		If the stock removal sensor is installed it is not calibrated correctly, please look in the manual for the stock removal sensor.



*AbraPol-20*  
*Instruction Manual*

<b>Fatal Errors</b>	<b>Explanation</b>	<b>Action</b>
15 V DC supply in pcb missing	Fault in the internal power supply.	Turn off unit at Main Switch. Please contact a Struers Service..
24 V DC supply in pcb missing	Fault in the internal power supply.	
No serial communication	No contact between machine system and Control panel.	
Program version mismatch	Conflict between software in machine control system and Control panel.	

## 5. Technical Data

Subject		Specifications	
		Metric/ International	US
<i>Disc</i>	Rotational speed	50-500 rpm in steps of 10	50-500 rpm in steps of 10
	Size	300/350 mm	11.8"/13.7"
	Power Consumption	2.2 kW	3 Hp
<i>Specimens</i>	Speed	50-300rpm in steps of 10	50-300rpm in steps of 10
	Direction	CW/CCW	
	Force	0-700 N	0-150 lbf
	Motor power consumption	0.55 kW	0.75 Hp
<i>Dosing Unit</i>	Level	0-20	
	No. of pumps	3 (6 with Additional Dosing Unit)	
<i>Software and electronics</i>	LC Display	320x240 pixels	
	Controls	Touch pads/Push-turn knob	
	Memory	EPROM/RAM/NV-RAM	
<i>Dimensions and weight</i>	Width	840 mm	33.1"
	Depth	980 mm	38.6"
	Height	1560 mm	61.4"
	Weight	400 kg	880 lbs
<i>Environment</i>	Safety standards	Please refer to the Declaration of Conformity	
	Noise level (idle 300/300)	77 dbA	
	Surrounding temperature	5-40°C	
	Humidity	Max. 95%RH	
<i>Water mains</i>	Water supply max. 10 bar	max. 10 bar	
<i>Compressed air</i>	Compressed air supply Recommended quality, ISO 8573-1, class 5.6.4 for normal use	6-10 bar	

AbraPol-20  
Instruction Manual

Subject	Specifications				
<b>Electrical Data</b>					
	Power consumption	3 kW			
	No. of phases	3 (3L+PE)			
	Output, main motor	2.2 kW			
	Voltage/frequency:	Max. load			
	3 x 200 - 210 V / 50/60Hz	16.5 A			
	3 x 220 - 240 V / 50/60 Hz	15.6 A			
	3 x 380 - 415 V / 50/60 Hz	9.0 A			
	3 x 460 - 480 V / 50/60 Hz	7.2 A			
<i>Mains Cable Recommendation</i>	<i>Voltage/frequency:</i>	<i>Min. Fuse size</i>	<i>Minimum cable size @ Min. fuse</i>	<i>Max. Fuse size</i>	<i>Minimum cable size @ Max. fuse</i>
	3 x 200 - 210 V / 50/60Hz	25 A	3xAWG12 / 4 mm <sup>2</sup> + PE	50 A	3x AWG10 / 4 mm <sup>2</sup> + PE
	3 x 220 - 240 V / 50/60 Hz	25 A	3x AWG12 / 4 mm <sup>2</sup> + PE	50 A	3x AWG10 / 4 mm <sup>2</sup> + PE
	3 x 380 - 415 V / 50/60 Hz	20 A	3x AWG12 / 4 mm <sup>2</sup> + PE	50 A	3x AWG10 / 4 mm <sup>2</sup> + PE
	3 x 460 - 480 V / 50/60 Hz	20 A	3x AWG12 + PE	50 A	3xAWG10 + PE
<i>Protective Earth Cable Recommendation</i>	<i>Voltage/frequency:</i>	<i>Cable size</i>			
	3 x 200 - 210 V / 50/60Hz	AWG 10			
	3 x 220 - 240 V / 50/60 Hz	AWG 10			
	3 x 380 - 415 V / 50/60 Hz	4 mm <sup>2</sup>			
	3 x 460 - 480 V / 50/60 Hz	AWG 10			
	<p><b>Important:</b> Local standards may overrule the recommendations for the main supply cable. If necessary, please contact a qualified electrician to verify which option is suitable for the local installation setup.</p>				
<i>Residual Current Circuit Breaker</i>	type B, 30 mA (or better) is REQUIRED.				

## 6. Menu Overview

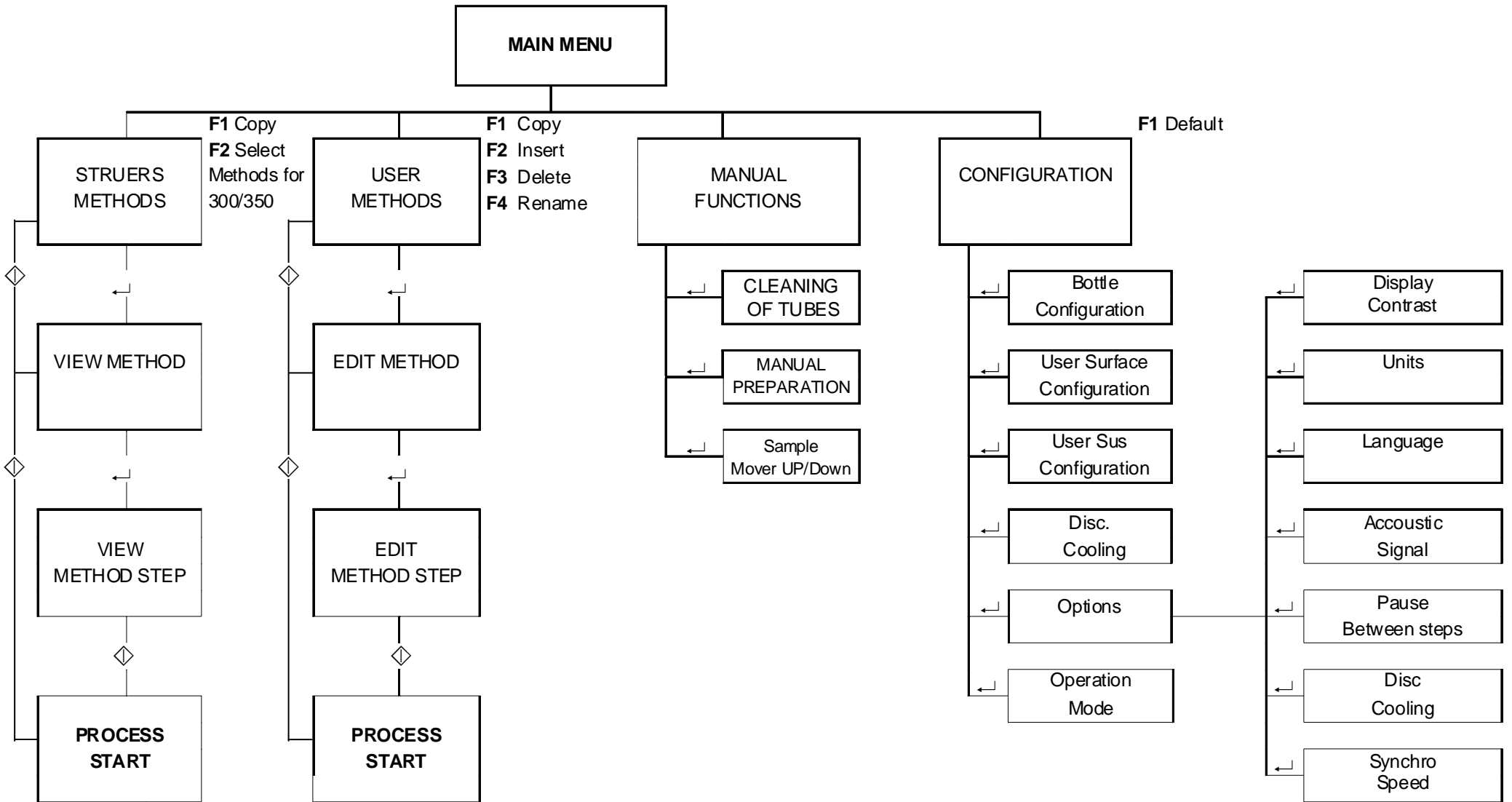

# Quick Reference Guide

## **Description**

AbraPol-20 is an automated machine ideal for laboratories or workplaces carrying out quality control testing on a large number of specimens. AbraPol-20 has the unique possibility of preparation on a 350 mm disc. Furthermore, the Speed of specimen holder and speed of disc can be set to 300 rpm, resulting in reduced grinding and polishing time.

## **Main Controls**

### *Main Switch*

The main switch is located at the right side of the machine.

### *Emergency Stop*

Red push button on the front of the machine. Stops all ongoing operations. Release the emergency stop by pulling the button.

### *Double Start Buttons*

Start the actual preparation by pressing the two buttons simultaneously.

## **Front Panel Controls**

### *Manual Functions*

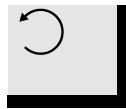

Start the Rotation of the disc

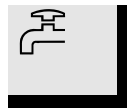

Switch the Water on



Manual dosing of Lubricant



Manual dosing of Abrasive

### *Function Keys*

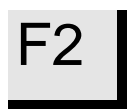
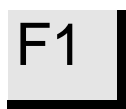

Controls for various purposes.  
See the bottom line of the individual screens.

### *Stop and ESC*

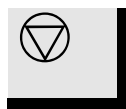

Stops the grinding or polishing process



Leaves the present menu or aborts Edit functions/changes

### *Turn / Push Knob*

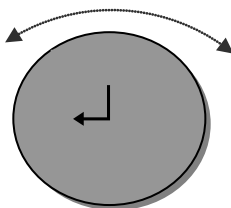

The Knob is used for entering and changing steps and parameters.

Combined cursor and enter key.

### **Running a Struers Method**

- Press ESC to get up to Main Menu.
- Select Struers Methods in Main Menu, by turning the knob.
- Push the knob for entering Struers Methods.
- Turn the knob to select the chosen Struers Method.
- View Method by pushing the knob.
- Start the preparation by pressing the two double start buttons simultaneously.

### *Editing process*

- For editing the process, push knob during the process.

### **Copying a Preparation Method**

- Turn the knob to select the preparation method you want to copy.
- Press **F1** for copying a Preparation Method
- Press **F1** to accept copying
- Enter the screen USER METHODS press **F2** to insert the method

### **Editing Names**

- Select the method name you want to edit.
- Edit name by pressing **F4**.
- Use knob to select/insert character.
- Move the cursor left or right by pressing **F1** or **F4**.
- Press **F2** to accept the new name.

### **Modifying a Preparation Method**

- Select User Methods in Main Menu, by turning the knob.
- Push the knob for entering User Methods.
- Select the Preparation Method and the step you want to change.
- Turn the knob to the parameter you want to change.
- Push the knob and select the new parameter.
- Save changes by pressing **F4**.

English

## Declaration of Conformity

 Struers

**Manufacturer,  
responsible for  
Technical File**

Struers ApS  
Pederstrupvej 84  
DK-2750 Ballerup, Denmark  
Telephone +45 44 600 800

Herewith declares that

<i>Product Name:</i>	AbraPol-20
<i>Type No.:</i>	588
<i>Machine Type:</i>	Grinding and polishing machine

is in conformity with the provisions of the following directives:

**Safety of Machinery** 2006/42/ EC according to the following standard(s):  
EN ISO 12100:2010, EN ISO 13849-1:2008/AC:2009, EN ISO 13849-2:2012, EN ISO 13850:2008,  
EN 60204-1:2006/AC:2010, EN 574:1996+A1:2008, EN 953:1997+A1:2009.

**EMC-Directive** 2014/30/EU according to the following standard(s):  
EN 61000-6-1:2007, EN61000-6-3:2007/A1:2011.

**RoHS** 2011/65/EU according to the following standard(s):  
EN 50581:2012.

**Supplementary Information** The equipment complies with the American standards:  
UL508, NFPA70:2014; NFPA79:2012. FCC 47 CFR part 15.

**The above has been declared according to the global method, module A**

Date: 23.02.2016

  
Christian Skjold Heyde,  
Vice President, R & D and Production, Struers ApS

Dansk

## Overensstemmelseserklæring

 Struers

**Fabrikant,  
ansvarlig for Teknisk  
Dossier**

Struers ApS  
Pederstrupvej 84  
DK-2750 Ballerup, Danmark  
Telefon 44 600 800

erklærer herved, at

<i>Produktnavn:</i>	AbraPol-20
<i>Type nr.:</i>	588
<i>Maskintype:</i>	Slibe og poliemaskine

er i overensstemmelse med følgende EU-direktiver:

**Maskindirektivet** 2006/42/EF efter følgende norm(er):  
EN ISO 12100:2010, EN ISO 13849-1:2008/AC:2009, EN ISO 13849-2:2012, EN ISO 13850:2008,  
EN 60204-1:2006/AC:2010, EN 574:1996+A1:2008, EN 953:1997+A1:2009, EN 60204-  
1:2006/AC:2010.

**EMC-direktivet** 2014/30/EU efter følgende norm(er):  
EN 61000-6-1:2007, EN61000-6-3:2007/A1:2011.

**RoHS** 2011/65/EU efter følgende norm(er):  
EN 50581:2012.

**Supplerende oplysninger** Endvidere overholdes de amerikanske normer:  
UL508, NFPA70:2014; NFPA79:2012. FCC Part 15.

**Ovenstående overensstemmelse(r) er erklæret iflg. den globale metode, modul A**

Dato: 23.02.2016

  
Christian Skjold Heyde,  
Vice President, Udvikling og Produktion, Struers ApS

# Letter of conformity

Date 2013-03-14

## Struers A/S

Pederstrupvej 84  
DK-2750 Ballerup, Denmark

Phone +45 44 600 800

Fax +45 44 600 801

struers@struers.dk

www.struers.com

Bankers:

Nordea Bank Denmark A/S

Account no.: 2191-0126305060

VAT no.: 15683309

## **Letter of conformity: Safety hood/window for the following equipment**

AbraPlan-20	PETG thickness: 8 mm
AbraPol-20	PETG thickness: 8 mm
Discotom-5/-6/-10/-60/-65/-100	PETG thickness: 4 mm
Labotom-3	PETG thickness: 4 mm
Labotom-5	PETG thickness: 3 mm
Labotom-15	PETG thickness: 5 mm
Axitom/-5	PETG thickness: 4 mm
Exotom-100/-150	PETG thickness: 4 mm
Magnutom-400/-500	PETG thickness: Front: 10mm, Side: 8mm

The safety hoods/window primary function is to protect against samples not clamped properly.

The safety hood is made from PETG, which is generally used in all Struers machines as "safety glass".

PETG is resistant to scratches and chemicals and provides the highest degree of safety for the operator.

**Commodity Supplier:** RIAS A/S, Industrivej 11, 7000 Roskilde, Denmark

**Producer:** NEOPLAST ApS, Tingbjergvej 4, 4632 Bjæverskov, Denmark

**Supplier:** Struers A/S, Pederstrupvej 84, 2750 Ballerup, Denmark

This is to certify that the product is produced according to regulations from the Commodity Supplier.

Yours faithfully

Flemming Perret-Gentil  
R&D Manager  
R&D Department, Equipment

+45 44 600 913 (direct)

+45 27 130 890 (mobile)

[flemming.perret.gentil@struers.dk](mailto:flemming.perret.gentil@struers.dk)

[www.struers.com](http://www.struers.com)







Pederstrupvej 84  
DK-2750 Ballerup  
Denmark

# AbraPol-20



## Spare Parts and Diagrams

Manual No.: 15887001

Date of Release GH01 .201H



*AbraPol-20*  
*Spare Parts and Diagrams*

---

**Always state *Serial No* and *Voltage/frequency*  
if you have technical questions or when ordering spare parts.**

The following restrictions should be observed, as violation of the restrictions may cause cancellation of Struers legal obligations:

**Instruction Manuals:** Struers Instruction Manuals may only be used in connection with Struers equipment covered by the Instruction Manual.

**Service Manuals:** Struers Service Manuals may only be used by a trained technician authorised by Struers. The Service Manual may only be used in connection with Struers equipment covered by the Service Manual.

Struers assumes no responsibility for errors in the manual text/illustrations. The information in this manual is subject to change without notice. The manual may mention accessories or parts not included in the present version of the equipment.

**Original instructions.** The contents of this manual are the property of Struers. Reproduction of any part of this manual without the written permission of Struers is not allowed.

All rights reserved. © Struers 201H

**Struers A/S**  
Pederstrupvej 84  
DK-2750 Ballerup  
Denmark  
Telephone +45 44 600 800  
Fax +45 44 600 801

---

# Spare Parts and Diagrams

## Table of contents

## Drawing

### AbraPol-20

#### *Drawings*

AbraPol-20, complete.....	15880001O
Casing with electrical, assembled.....	15880005E
Casing with motors, assembly.....	15880007C
Casing, assembly.....	15880010I
Main mechanism, assembly.....	15880020F
Box for tub, assembly.....	15880050C
Tub, assembled.....	15880058D
Sample motor, assembly.....	15880045E
Plate with PCB and pneumatic distr. assembled.....	15880034B
Control box AbraPol-20, assembled.....	15880082I
Front, assembly.....	15880025B
Dosing Arm, assembled.....	15090055E
Safety guard, assembly.....	15890080D
Top water valve.....	15880095D
Window, assembled.....	15090004
Quick-release coupling, complete.....	15090009C
Disc, assembled.....	15090005
Air connection, assembled.....	15090032E
Pumps module, assembly.....	15880051F
Valves for Cooli water.....	15880090C

#### *Diagrams*

Transformer Connections (2 pages).....	15093452A
Air diagram.....	15882000C
Water connections.....	15882005B
Block diagram.....	15883050E
Circuit diagram main voltage.....	15883100E
CPU Board A1 (5 pages).....	15883120F
Doser connection board.....	15883200A
Wiring diagram (10 pages).....	15883450E
Overview, variant parts AbraPol-20.....	15887600D

Some of the drawings may contain position numbers  
not used in connection with this manual.

## **Spare Part list for AbraPol-20**

**Drawing**

15880001

<b>Pos.</b>		<b>Cat no.</b>
	<b>AbraPol-20, complete</b>	
0120	Splash ring.	15090900
0140	Tube connection	15090920
0170	Flange bearing GFM-2528-21	2BG00089
0210	Bevel washer 16 DIN 125B FZB	2ZC11630
0230	Safety guard, assembly	15890080
0240	Down arm	15890930
0270	Flange bearing GFM-2023-07	2BG00088
0290	Top water valve	15880095
0320	CLIMADUCT GF 2in 2750	2NU30300
0400	Windows, assembled	15090004
0410	Quick-release coupling, complete	15090009
0450	Spring ring SB 16	2ZM30160
0480	Turntable w. quad rings (ø350 mm)	15090005
0640	Rubber	15890508
1040	1.0AT aM-fuse 10x38	2FC10010
1030	16.0AT aM-fuse 10x38	2FC10160
1040	1.0 AT Cl.-CC fuse 10x38 CSA	2FC11010
1040	2.0 AT Cl.-CC fuse 10x38 CSA	2FC11020
1040	2.0 AT Cl.-CC fuse 10x38 CSA	2FC11020
1030	15.0 AT Cl.-CC fuse 10x38 CSA	2FC11150
1030	20.0 AT Cl.-CC fuse 10x38 CSA	2FC11200
1030	20.0 AT Cl.-CC fuse 10x38 CSA	2FC11200
1050	CAN-module f. Lenze freq.conv.	2PU82000
1000	Lenze freq.conv. 3x230V 3.0kW	2PU82302
1000	Lenze freq.conv. 3x400V 3.0kW	2PU84302

15880005

	<b>Casing with electrical, assem.</b>	
0140	Connector 9-pol.male 715270211	2XM11527
0180	Dust cap 9-pol.D-sub male	2XM90009
0220	Universal angle type F-90 PG21	2GK20045
0230	Check-nut PG21 Brass DIN46320	2TD20109
0310	Neoprene bushing ø20/ø28/ø36-4	2GK90147
0380	Tube for wires PA ø31.3/ø23.7	2NU32004

## **Spare Part list for AbraPol-20**

**Drawing**

[15880007](#)

<b>Pos.</b>		<b>Cat no.</b>
	<b>Casing with motors, assembly</b>	
0060	Rubber bushing	15090690
0070	Rubber disc Ø12/Ø26.4	11440069
0100	Conduit BA6 15015	2GO80015
0270	Pressure spring Ø12X1.5	14220365
0300	Locking rail	15090410

[15880010](#)

	<b>Casing, assembly</b>	
0030	Machine leg M75-16-070	2GB40075
0210	Key Lock Switch AZM 170-02ZRKA 24V	2SS00007
0280	Conduit BA6 30025	2GO80025
0330	Neoprene bushing ø53/ø64/ø75-2.5	2GK90459
0340	Sealing strip Grey 1.5x19	2IP10152
0390	Armed PVC HOSE 1/2" -ø12.5 for water.	2NU29316
0400	Hose clamp 12-20 / 9.0-C6 W2.	2NS21220
0410	GEKA hose connection 1-2	2NF60000

## **Spare Part list for AbraPol-20**

**Drawing**

15880020

<b>Pos.</b>		<b>Cat no.</b>
	<b>Main mechanism, assembly</b>	
0080	Cylinder EDCQ 2B 50-OD	2YC50101
0090	REED-Contact D-A73L	2KR30177
0100	Gasket, PVC 1/4"	2IF00012
0110	Nipple 2531-1/4-1/8	2NF40041
0120	Gasket, PVC O-1/8	2IF00011
0130	Banjo to quick-coupling ø5-1/8	2NF10034
0140	Banjo screw 1631-02-1/8	2NF20032
0170	Coupling FLEXO FK-M10	2JH50010
0200	Ball bushing KH4060	2BF20040
0210	INA-Sealing ring G 40x52x5	2II04052
0220	Upper guide	15090350
0275	Sealing strip Black 6x12	2IP00601
0280	Distance ring-ball bearing	14590017
0290	V-Belt SPZ-2 ø315	2JE00315
0300	Adapter 2012/ø35	2JE92035
0320	Pressure disc-V-belt	14590018
0350	V-belt XP2/3V 132mm	2JD01320
0370	Slat for tensing	15890710
0420	Sliding rail, Chromit+painted	15099007
0440	Dial rail	15090330
0460	Blocking valve R 1/4"	2YH60004
0470	Quick-coupling, straight ø5-M5	2NF10011
0480	Air tube ø5/ø3.2 Superflex	2NU12445

15880050

	<b>Box for tub, assembly</b>	
0050	Bearing housing for dosing arm, SurTec	15090160
0070	Magnet catch black, double	2GL30035
0110	Doser Conn. Board PCB, Tested	15883000
0160	Holder for waste tube	15890509



## **Spare Part list for AbraPol-20**

**Drawing**

15880058

<b>Pos.</b>		<b>Cat no.</b>
	<b>Tub, assembled</b>	
0010	Tub	15880240
0020	Nozzle for disc cooling	15090885
0040	Quick-coupling conical S6510-04-1/8	2NF10006
0050	Tube for tub	15880241
0060	Elbow 87° for hose, ø38/pipe socket, ø40	2NG20440
0070	Tube with coupling Ø40x250 18 6011 025	2NG40025

15880045

	<b>Sample motor, assembly</b>	
0040	Motor 3x230VD/50 0,55kW 2p CSA	2MD10000
0080	Coupling	15490410
0100	Flex hose PMA PIST-17S.30	2NU31200
0110	Hose union	2NM10471
0120	Hose union 45° SVAO-P167T	2NM10437

15880034

	<b>Plate with PCB and pneumatic d</b>	
0060	Air tube ø5/ø3.2 Superflex	2NU12445
0070	Pressure nipple RTU PK3/3	2NF40242
0080	Neoprene nipple ø36/ø47/ø54-2.5	2GK90457
0130	Pressure Regulator, 5-8.5 bar 1/4in	2YR00001
0140	Quick release angle swivel connector ø5-1/8"	2NF10082
0150	Gasket, PVC 1/4"	2IF00012
0160	Cork 2611 1/4"	2NF40072
0170	Gasket, PVC O-1/8	2IF00011
0180	Throttle-sound absorber. RSS-111-M35-1/8	2YL00035
0190	Nipple 2531-1/4-1/8	2NF40041
0200	Banjo screw 1631-03-1/8"	2NF20080
0210	Banjo til quick-coupling ø5-1/8	2NF10034
0250	Magnetic valve. 3/2 24V DC 1/8	2YM10030
0260	quick-coupling 6511-5- 1/8	2NF10012
0280	Gasket, PVC M5	2IF00010
0300	Quick-coupling ø5-M5	2NF10081
0310	Sound absorber, SINTER 2931-M5	2YL00015
0330	3/2 solenoid valve 24VDC	2YM10124
0340	Strip int. adhesive 2-2.25mm	2GX20008
0380	PCB AbraPol-20 A2, tested	15883002

## **Spare Part list for AbraPol-20**

**Drawing**

[15880082](#)

<b>Pos.</b>		<b>Cat no.</b>
	<b>Control box AbraPol-20, assemb</b>	
0025	Window for display	15480465
0030	Display, 320X240 w. white LED	2HD32024
0080	2 channel opt. encoder w. pressure 24p	2HR12411
0100	O-ring 21.2 x 3.00 72 NBR 872	2IO30008
0110	Turn - Push Button	15090600
0130	Pushbutton Head RVAT DG stainl.	2SA00400
0140	Module holder f.3 elem. MHR-3	2SA41603
0160	Emergency stop ø22 type RV	2SA10400
0210	Main PCB, AbraPol-20, tested	15883001
0295	PCB for SMM, Tested	15483004

[15090055](#)

<b>Pos.</b>		<b>Cat no.</b>
	<b>Dosing Arm, assembled</b>	
0020	Vibration damper ø8x8-M3x6	2GS00108
0030	INA sealing ring SD 14x20x3	2II21420
0035	Cock spindle	15090125
0050	Gasket, PVC O-1/8	2IF00011
0055	reducer-muffe 2520-1/8-1/4 in	2NF40021
0060	Gasket, PVC 1/4"	2IF00012
0065	hose nipple 2601-12-1/4	2NF40087
0080	O-ring snor ø4	2IM10004
0090	Tube connection ø8x1 l=30	15090181
0100	Silicone hose 7/ø10	2NU19207
0110	Water pipe OB. GB	15090180
0120	Spray nozzle	13000032
0130	Doser arm OB:GL	15090150
0140	Cylinder pin	2ZS01410
0150	Nozzle block	15090140
0170	Nozzle pipe	14600034
0180	Tygon tube, enft. 21 Ø2.06	2NU91221
0210	OP-nozzle pipe	14600209
0220	Silicone tube Ø4/Ø6	2NU11454
0270	Reinforced tube 3/8 X 300	2NU29312
0290	Spring for dosing arm	15090151

## **Spare Part list for AbraPol-20**

**Drawing**

[15890080](#)

<b>Pos.</b>		<b>Cat no.</b>
	<b>Safety guard, assembly</b>	
0010	Hood for safety guard	15890440
0060	Flange bearing GFM-2023-07	2BG00088
0140	Straight Actuator AZ 17/170-B1	2SS10017

[15880095](#)

<b>Pos.</b>		<b>Cat no.</b>
	<b>Top water valve</b>	
0010	Solenoid valve, Triple 24Vdc green 311	2YM12311
0020	Reinforced tube 3/8 X 300	2NU29312
0050	Gasket, PVC O-1/8	2IF00011
0060	Single banjo 1/8	2NF10029
0070	Throttle valve	2YH00008
0080	Reduction coupling	2NF40061
0090	Hose nipple 2601-12-1/4	2NF40087
0095	Gasket, PVC 1/4"	2IF00012
0100	Reinforced tube 3/8 X 300	2NU29312
0110	Cork 2611 1/4"	2NF40072
0120	Socket 2543-1/4	2NF40052

[15090004](#)

<b>Pos.</b>		<b>Cat no.</b>
	<b>Window, assembled</b>	
0001	Window for doser module	15090225
0002	Glass door hinge set, 3-6MM, black	2GG20010
0003	Glass door handle 3-6MM, black	2GH50010

[15090009](#)

<b>Pos.</b>		<b>Cat no.</b>
	<b>Quick-release coupling, complete</b>	
0010	Pressure foot	12600711
0020	Guide	15490430
0030	Pressure spring Ø4.3X0.7	12600718
0040	Driving pin	12600717
0050	Shaft	15490400
0065	Ball KU 5.556 (ø7/32 in) RS.	2BA00055
0070	Locking ring A25, stainless DIN 471	2ZL30250
0080	Locking ring A48, stainless I DIN 471	2ZL30480

## Spare Part list for AbraPol-20

**Drawing**

15090005

Pos.		Cat no.
	<b>Disc, assembled</b>	
0004	Quad-ring 4326-366Y	2IQ04326
0005	Quad-ring 4441-366Y	2IQ04441
0006	Quad-ring 4450-366Y	2IQ04450
0010	Disc OB:E1	15090470

15090032

Pos.		Cat no.
	<b>Air connection, assembled</b>	
0040	Air filter, air regulation EAW3000-F02D-6	2YF00005
0050	Stop angle filter/regu.	2YR40320
0090	Gasket, PVC 1/4"	2IF00012
0100	Nipple 2531-1/4-1/8	2NF40041
0110	Gasket, PVC O-1/8	2IF00011
0120	Banjo screw 1631-03-1/8"	2NF20080
0130	Banjo for quick-coupling ø5-1/8	2NF10034
0140	PVC-Hose, clear 13/32"-Ø10	2NU19313
0145	PVC-pipe 10 mm	2NP00010
0150	Air tube ø5/ø3.2 Superflex	2NU12445
0160	Quick coupling	2NF10024
0170	End piece	2NF40071
0190	Angle Quick coupling, Ø8-1/4"	2NF10087
0200	Distance nipple.2525-1/4-1/4-27	2NF40181

15880051

Pos.		Cat no.
	<b>Pumps module, assembly</b>	
0020	DP pump complete with cables	15600026
0070	Neoprene bushing ø2/ø6.5/ø11-1.5	2GK90102
0080	Elbow pipe III	14600038
0090	Tygon tube, ENFT 21 Ø2.06	2NU91221

15880090

Pos.		Cat no.
	<b>Valves for Cooli water</b>	
0010	Ball valve 3-ways 3/8" internal	2YH03629
0020	Cock 3/8"-3/8", ballofix	2YH10602
0030	Gasket PVC 6-3/8	2IF00013
0040	Hose nipple 2601-12-3/8	2NF40088

## **Spare Part list for AbraPol-20**

**Drawing**

<b>Pos.</b>		<b>Cat no.</b>
	<b>Accessories</b>	
0010	Instruction Manual for AbraPol-20	15887000
0020	Bottle 1l. Complete	15090091
0030	Lid for Bottle 0.5L, Complete	14600603
0040	Plastic bottle Nat.Dia.76mm 0,5l	71000119
0070	Band 32-50 / 9.0-C6 W3	2NS23250
0080	PUR L suction hose Ø40	2NU30404
0085	PVC-pipe 40	2NP00040
0090	PUR L Suction hose Ø40	2NU30404
0100	Water hose, grey 3/4angle-3/4straight	2NU93020
0110	Transition tube 1/2" inside 3/4" outside	2NG30013
0120	Gasket Ø11/Ø24 x 1.5	13590359
0130	Gasket w filter 3/4 in	2IX20410
0150	Hose nipple OB. NI	13688045
0160	Pressure hose PVC 1/4in ARM.	2NU12403
0170	Tensioner NORMA S12/9Zy	2NS11209

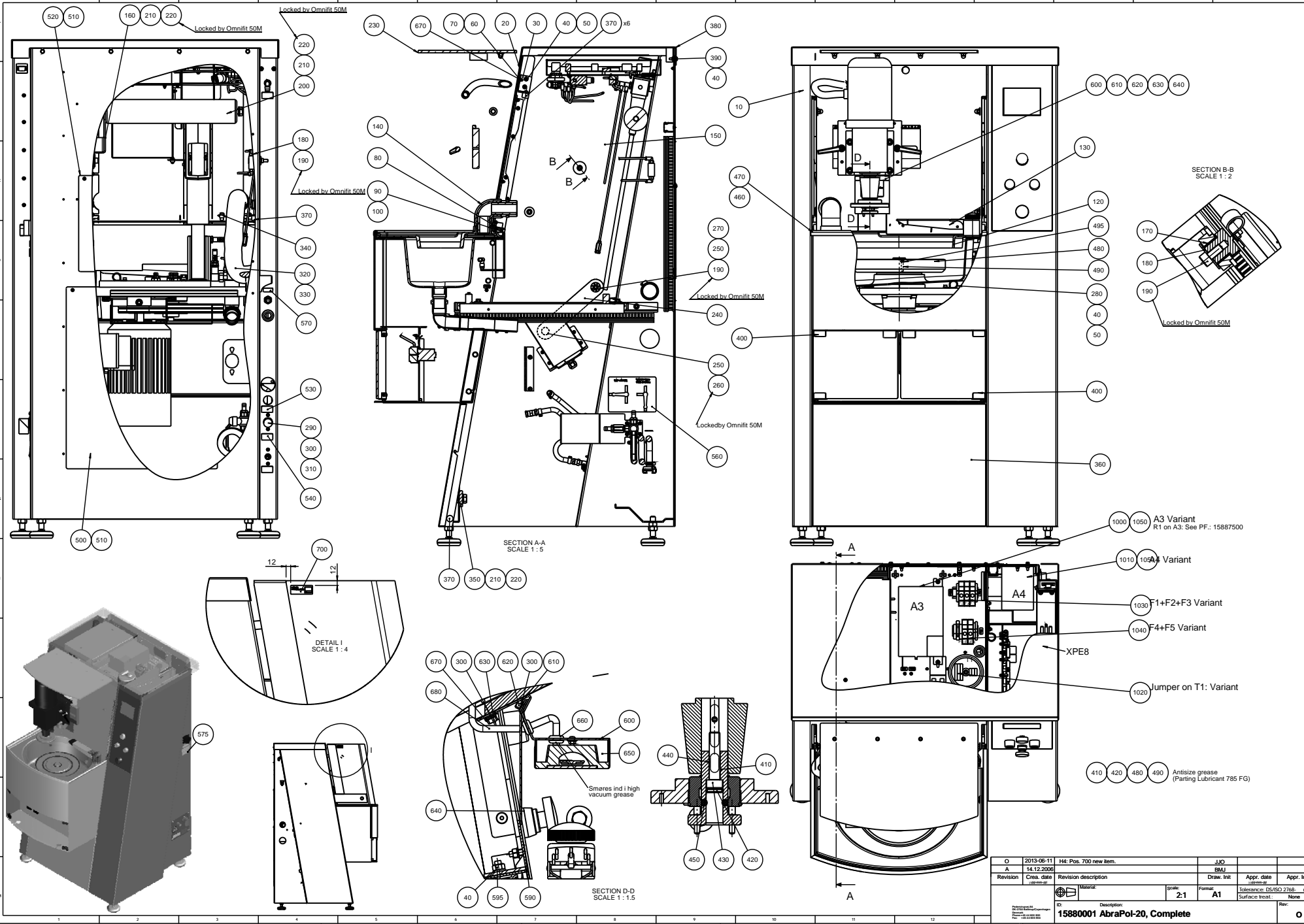

SECTION A-A  
SCALE 1 : 5

SECTION B-B  
SCALE 1 : 2

DETAIL I  
SCALE 1 : 4

SECTION D-D  
SCALE 1 : 1.5

O	2013-06-11	Hlt: Pos. 700 new item.	JJO		
A	14.12.2006	Revision description	BMJ		
Revision	Creo. date	Revision description	Draw. Int	Appr. date	Appr. Int
			scale: 2:1	Form: A1	Tolerance: DS/ISO 2768_mK
					Surface treat: None
ID: 15880001 AbraPol-20, Complete					Rev: O

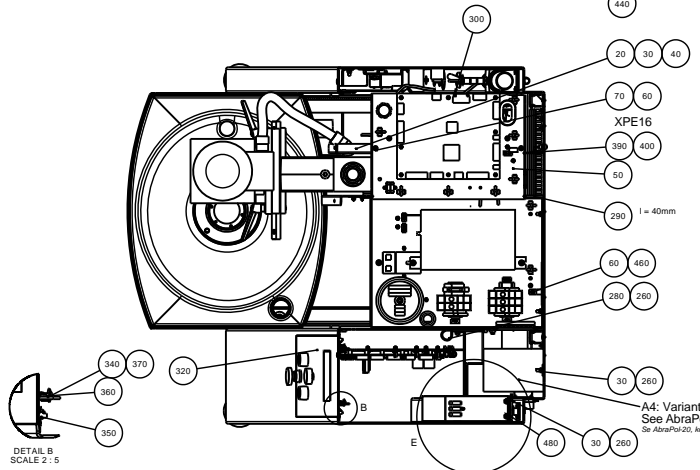
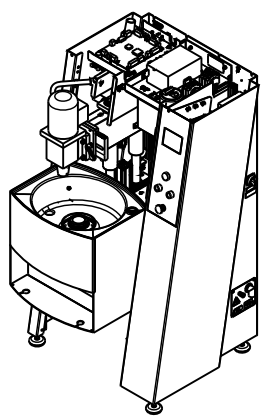
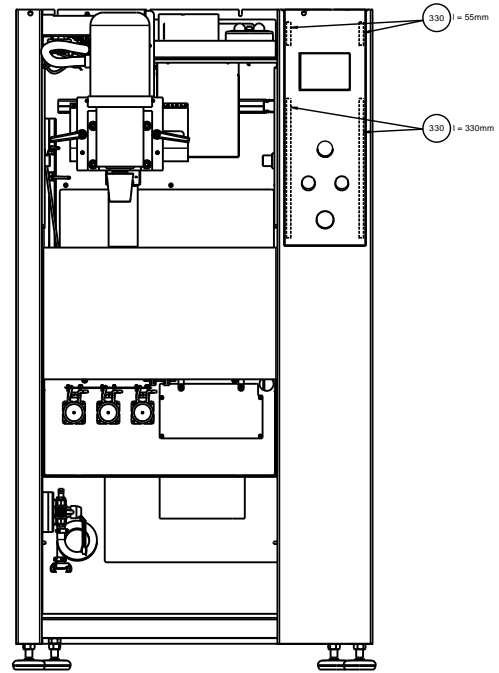
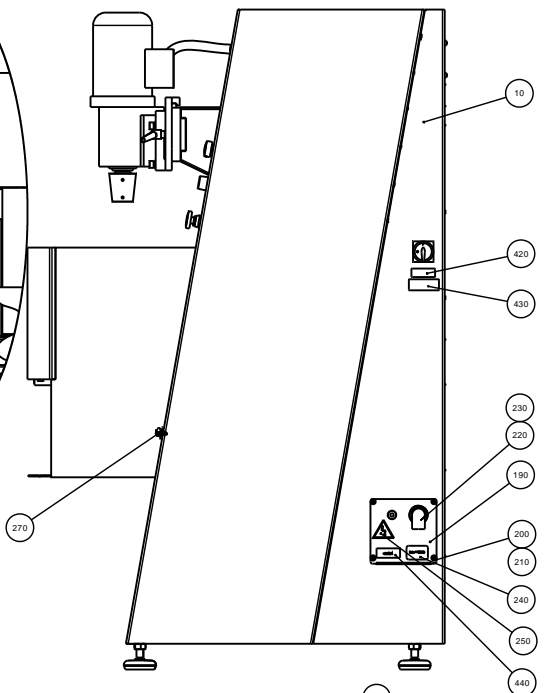
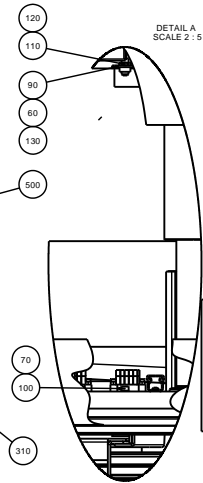
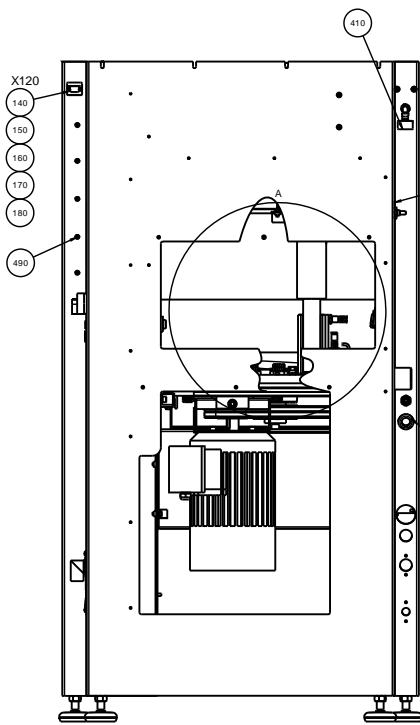

A4: Variant  
See AbraPol-20, complete  
(in AbraPol-20, komplet)

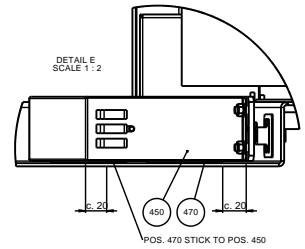

DETAIL B  
SCALE 2 : 5

E	2012-05-07	Pos. 500 lithogr.	JTV	2012-05-07	JTV
A	05-12-2006		IMJ		
Revision	Chra. date	Revision description	Draw. int.	Appr. date	Appr. int.
Material	Scale	Format	Surface treat.	None	
	1:5	A1			
Description					Rev.
15880005 Casing with electrical, assembly					E

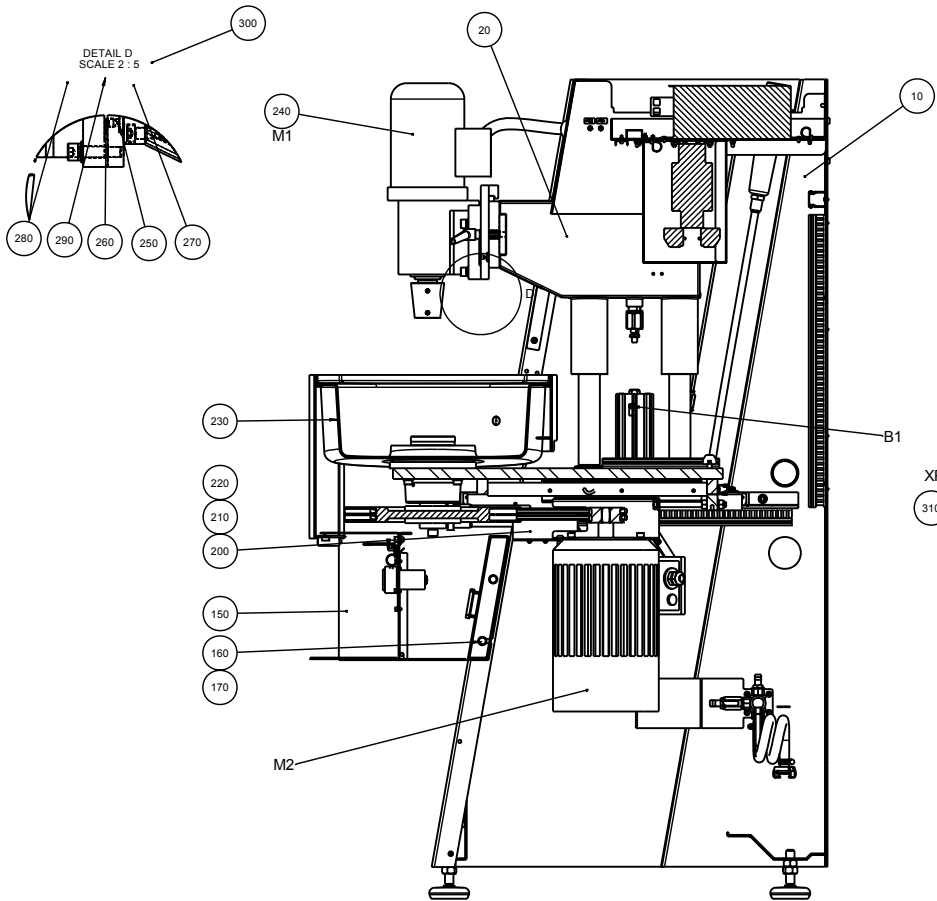

SECTION A-A  
SCALE 1:5

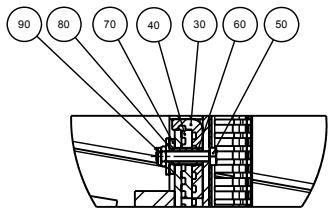
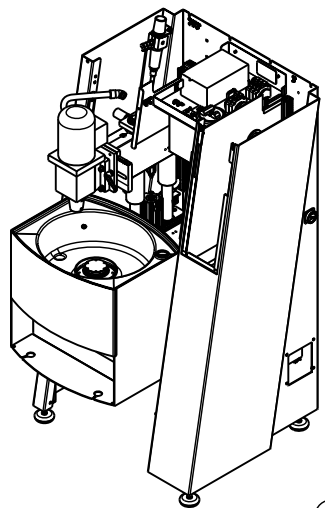

SECTION G-G  
SCALE 1:2

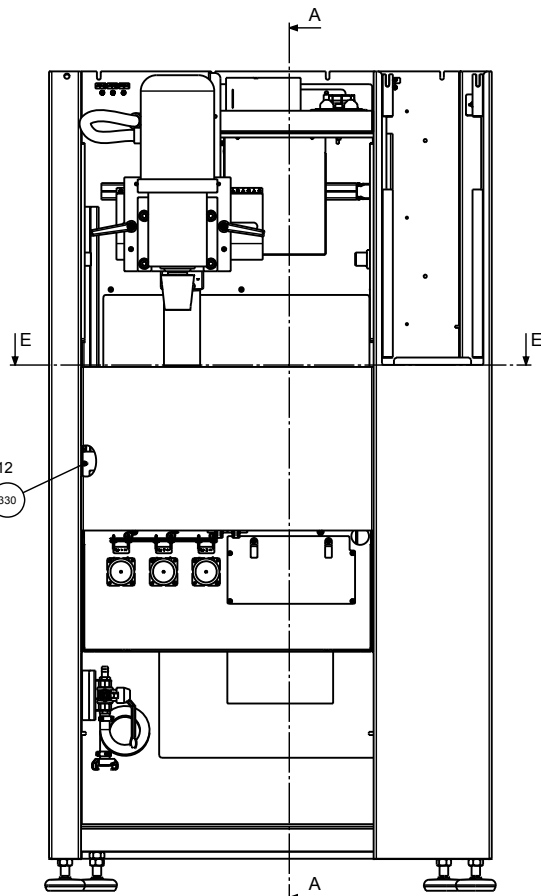

- 120
- 110
- 100
- 100
- 110
- 120
- 130
- 140

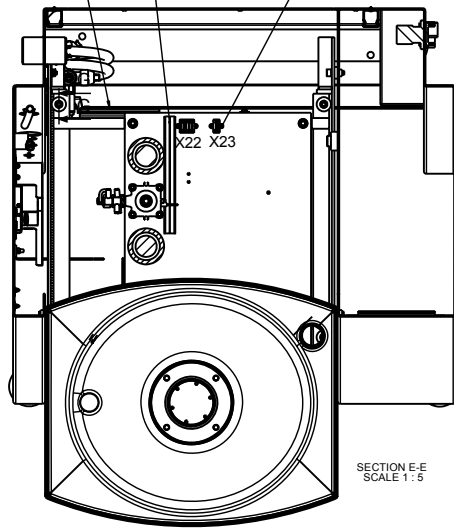

SECTION E-E  
SCALE 1:5

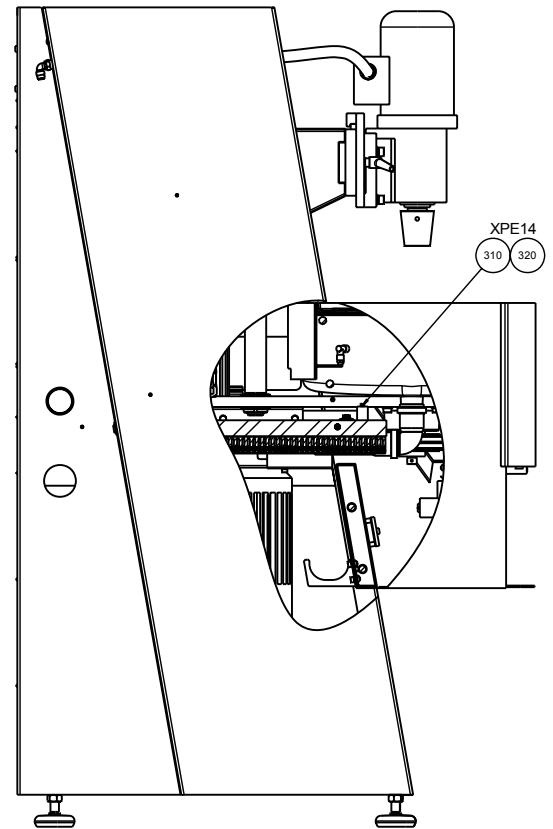

260 minifit 50

C	29.10.2007	Pos. 180 15890509+Pos. 190+2xpos.210 moved to 15880050	SPE	29.10.2007	
B	14.02.2007	Changed pos.130: 2G234308->2G244208	jF	14.02.2007	MD
A	07-12-2006		BMJ		
Revision	Crit. date	Revision description	Scale	Draw. Init	Appr. date
			1:2	A1	
		Material:		Tolerance: D5/ISO 2768-	Surface treat:
				None	
<b>15880007 Casing with motors, assembly</b>					Rev: c



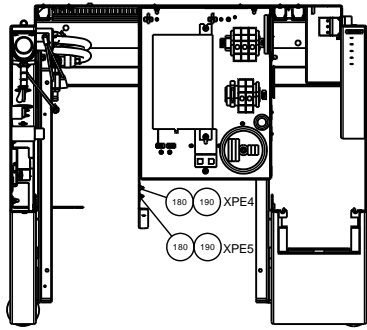
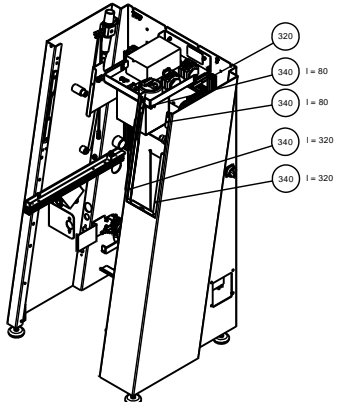
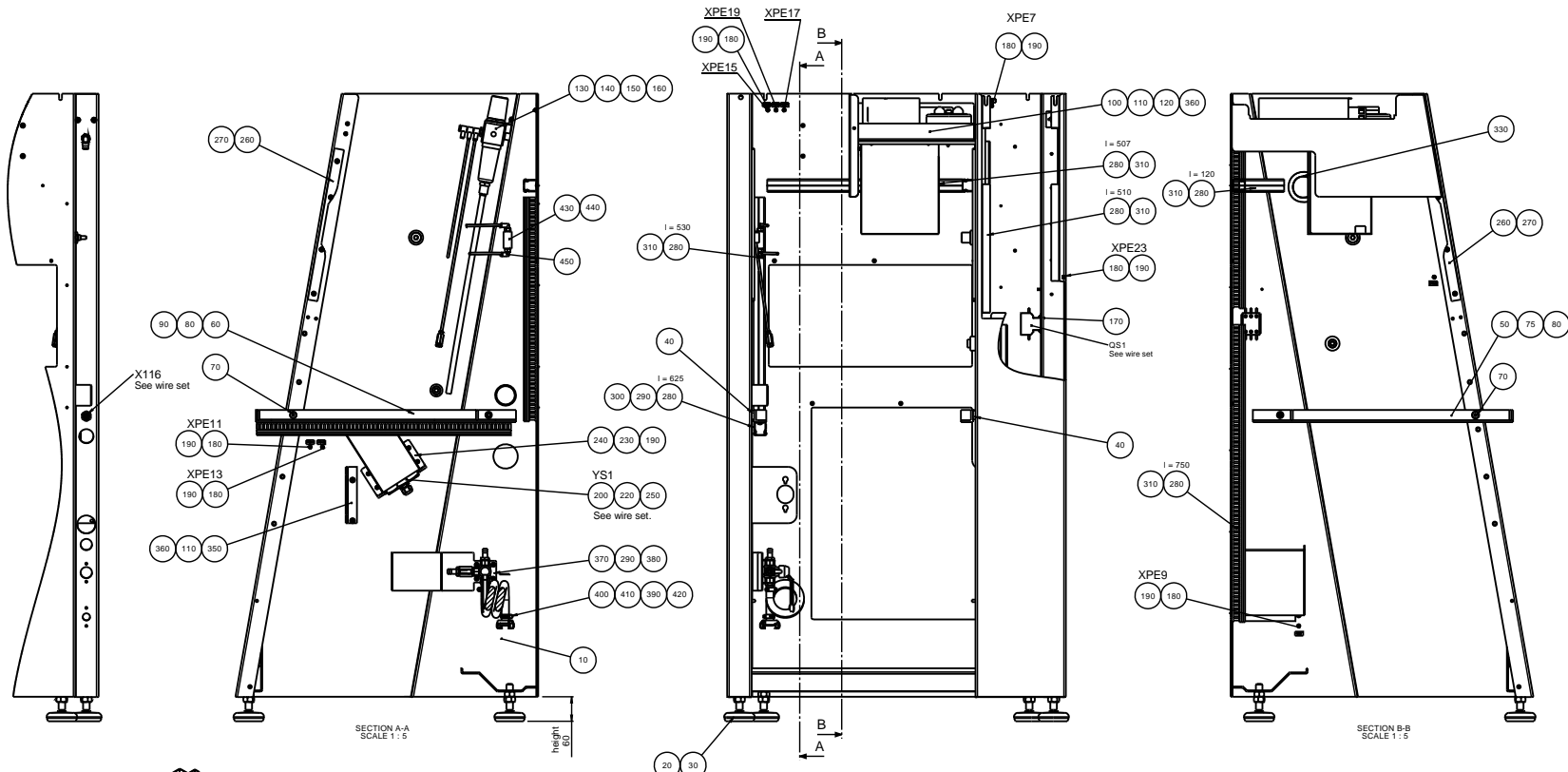

30 Pos 30 to be adjusted 60 0/+6mm from the floor to the edge of the cabinet (see section A-A).

I	2013-06-14	F7: Pos. 210 removed. Text added.	JJO		
A	06-12-2008		BMJ		
Revision	Crta. date	Revision description	Draw. int.	Appr. date	Appr. int.
		Format	Scale	Material	Surface treat.
		A1	2:1	ES/SGS 2765	None
Description:			Rev.		
15880010 Casing, assembly			I		

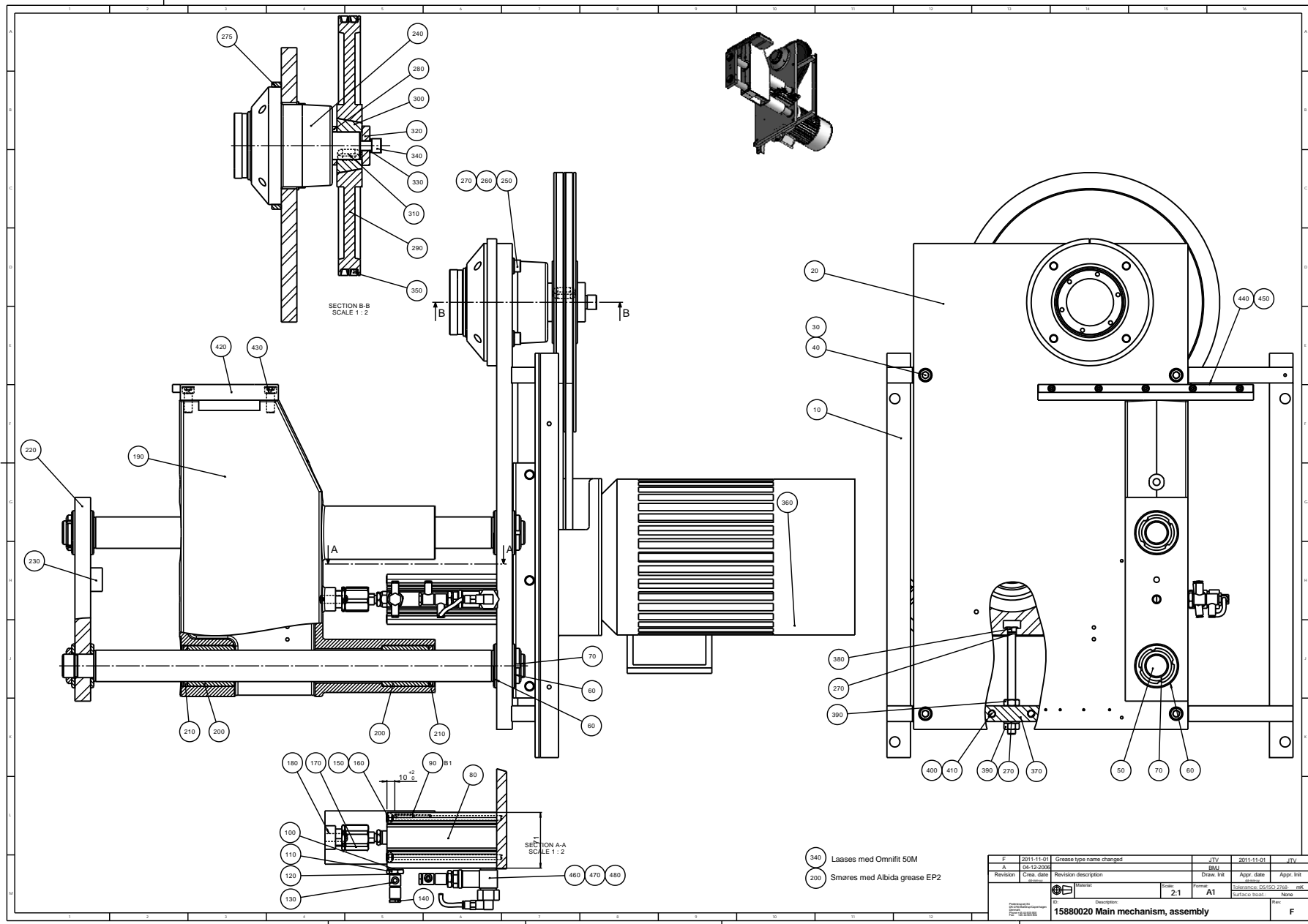

F	2011-11-01	Grease type name changed	JTV	2011-11-01	JTV
A	04-12-2006		BMJ		
Revision	Crsk. date	Revision description	Draw. int.	Appr. date	Appr. int.
				04-12-2006	BMJ
Material		Scale	Form	None	
		2:1	A1		
Description:					Rev.
15880020 Main mechanism, assembly					F

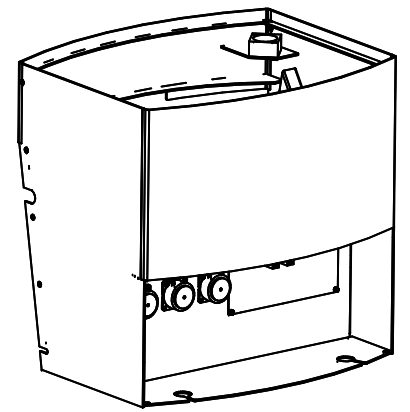
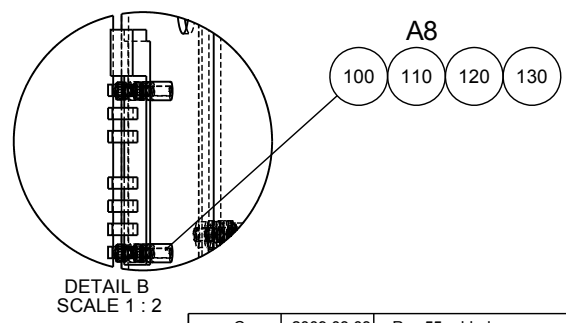
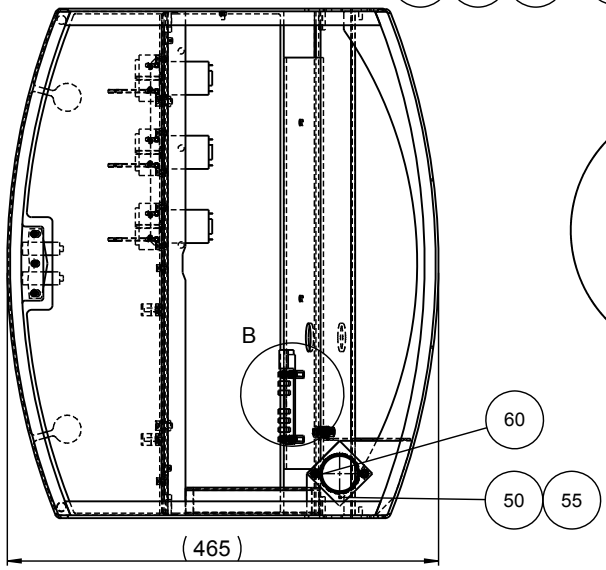
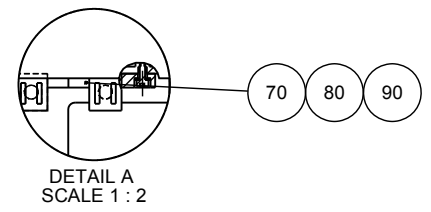
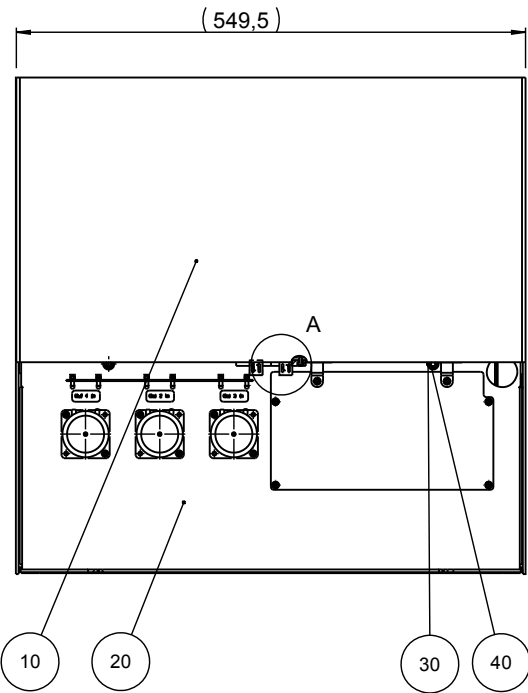
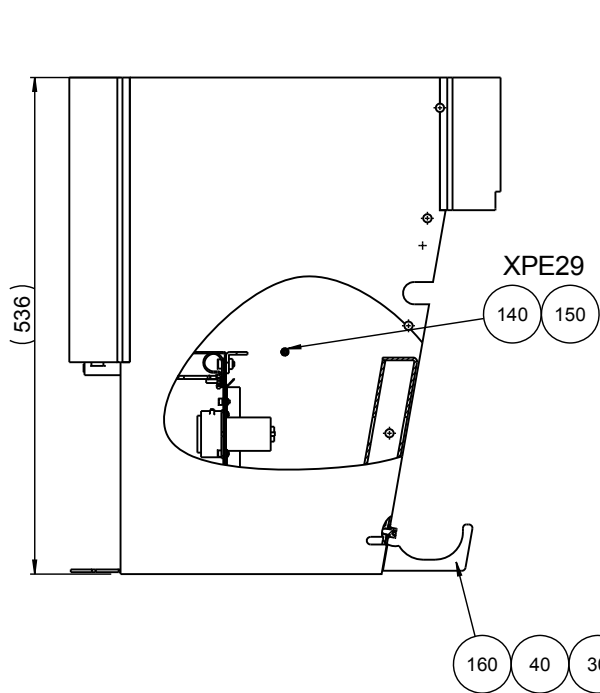

ISOMETRIC VIEW

C	2009.03.03	Pos.55 added	SPE	2009.03.03	
A	26.01.2006		JF	26.01.2006	FPG
Revision	Crea. date yyyy-mm-dd	Revision description	Draw. Init	Appr. date yyyy-mm-dd	Appr. Init
			Material:	Scale: 1:5	Format: A3
<small>Industrihøjvej 84 DK-2750 Ballerup/Copenhagen Denmark Phone: +45 44 600 800 Fax: +45 44 600 804</small>			ID:	Description:	Tolerance: DS/ISO 2768- mK Surface treat.: None
<b>15880050 Box for tub, assembly</b>					Rev: <b>C</b>

Limes med PVC lim

50

Pos. 50  
PVC rør udvides med værktøj  
15881501 i produktionen.

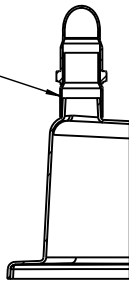

SECTION A-A

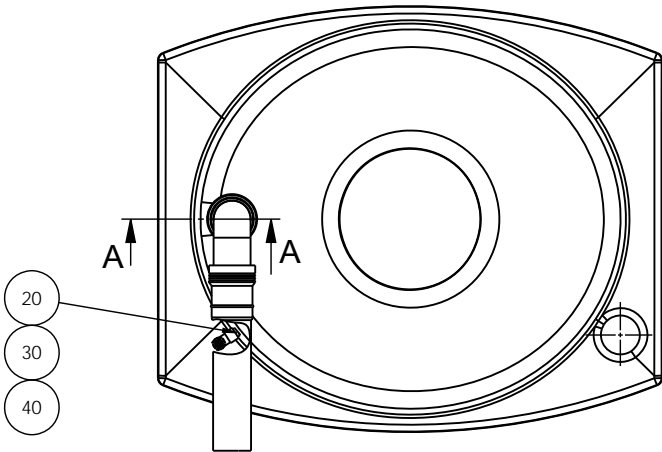
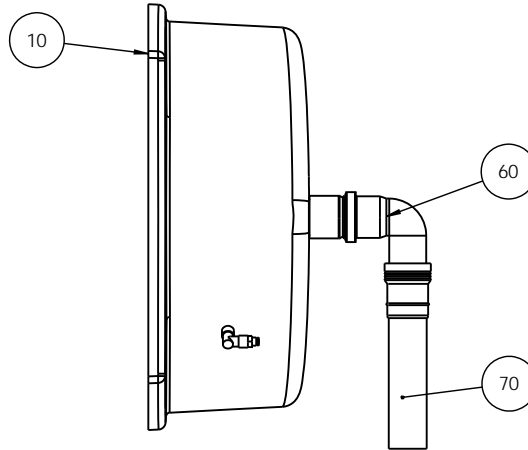
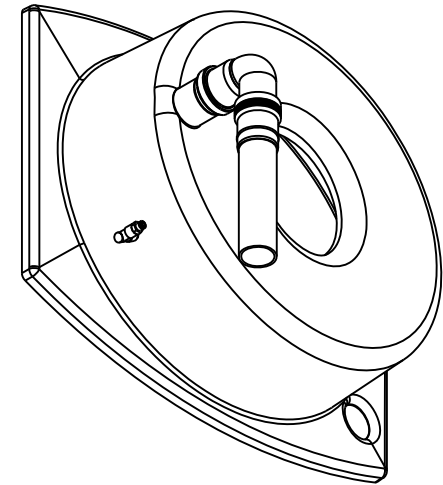

20

30

40

20 Seal Omnifit 100M

D	29.10.2008	Pos.70 15880242 added; See 1588LD01 list removed	SPE	29.10.2008	BRY
A	04.12.2006		SPE		
Revision	Crea. date dd-mm-yy	Revision description	Draw. Init	Appr. date dd-mm-yy	Appr. Init
	ID:	Material:	Scale: 1:5	Format: A3	Tolerance: DS/ISO 2768- mK
					Description: 15880058 Tub, assembled
					Rev: D



Pødenhusvej 84  
 DK-2750 Ballerup/Copenhagen  
 Denmark  
 Phone: +45 44 600 800  
 Fax: +45 44 600 804

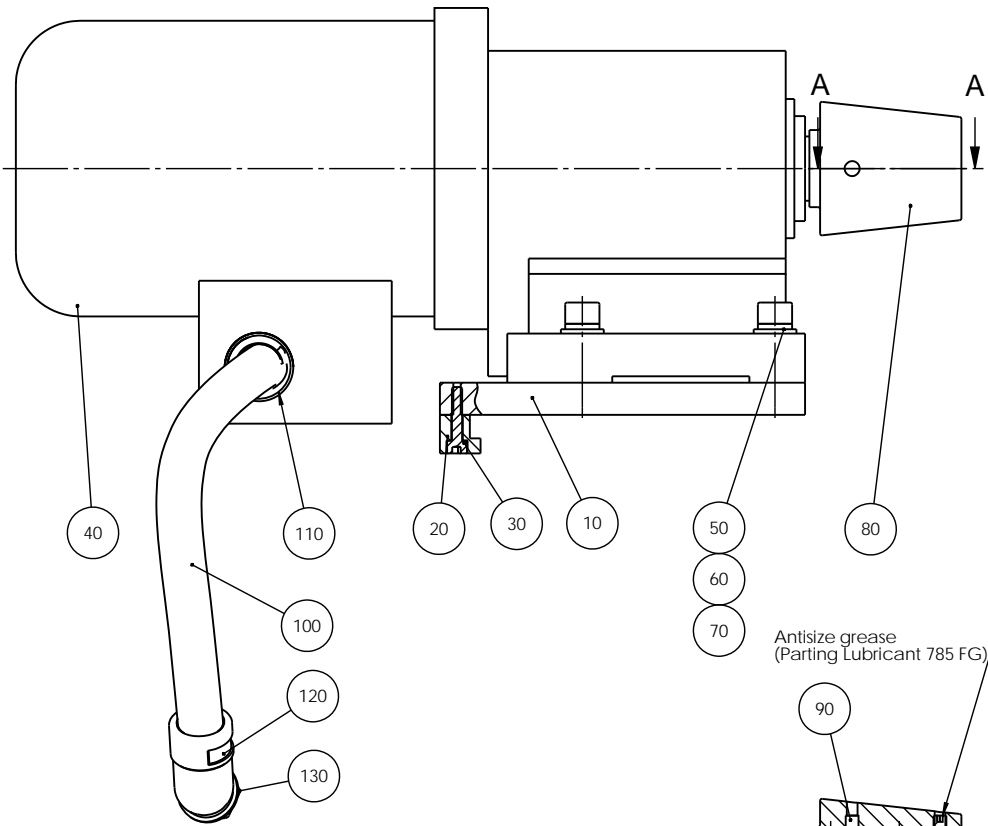
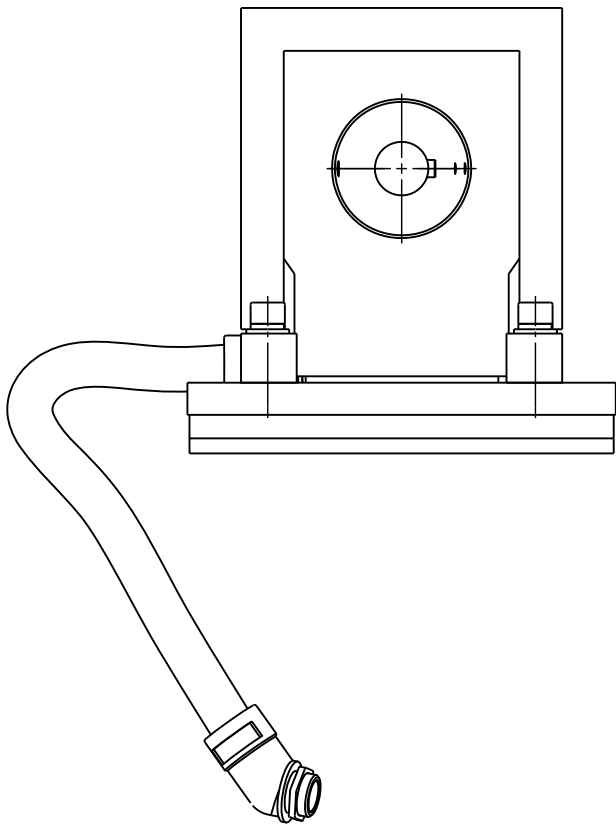

Antisize grease  
(Parting Lubricant 785 FG)

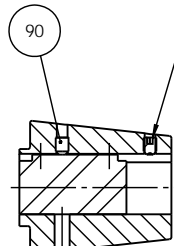

SECTION A-A  
SCALE 1 : 2

- 80 Varmes op til 150°C og krympes paa
- 90 Omnifit 50

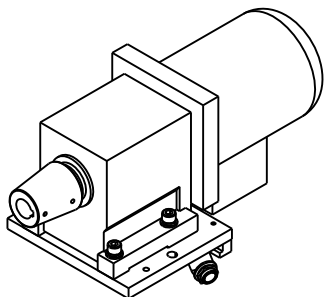

E	2013.07.31	PMA fittings changed Pos.100, 110,120,130	SPE	2013.07.31	
A	28-11-2006		YKJ		
Revision	Crea. date dd-mm-yy	Revision description	Draw. Init	Appr. date dd-mm-yy	Appr. Init
		Material:	Scale: 1:2	Format: A3	Tolerance: DS/ISO 2768- mK Surface treat.: None
		ID:	Description: <b>15880045 Sample motor, assembly</b>		Rev: <b>E</b>

Federstrømsgvej 84  
DK-2750 Ballerup-Copenhagen  
Denmark  
Phone: +45 44 600 800  
Fax: +45 44 600 804

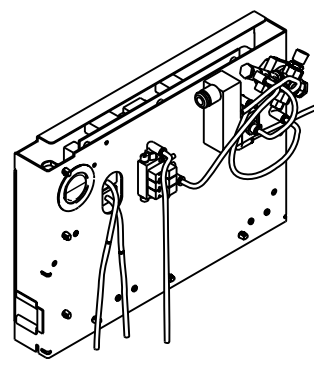
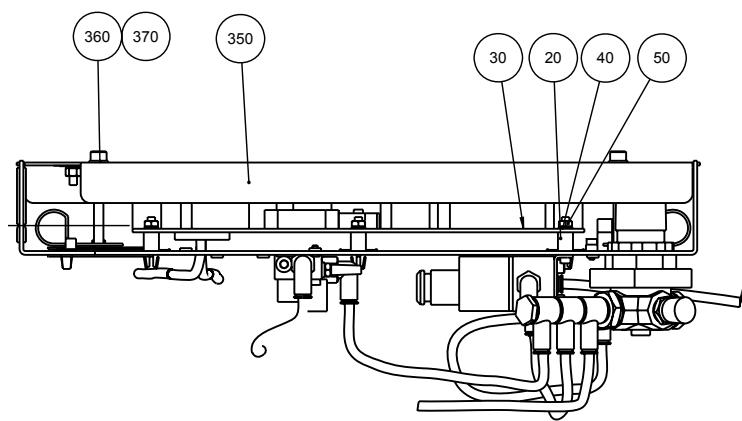
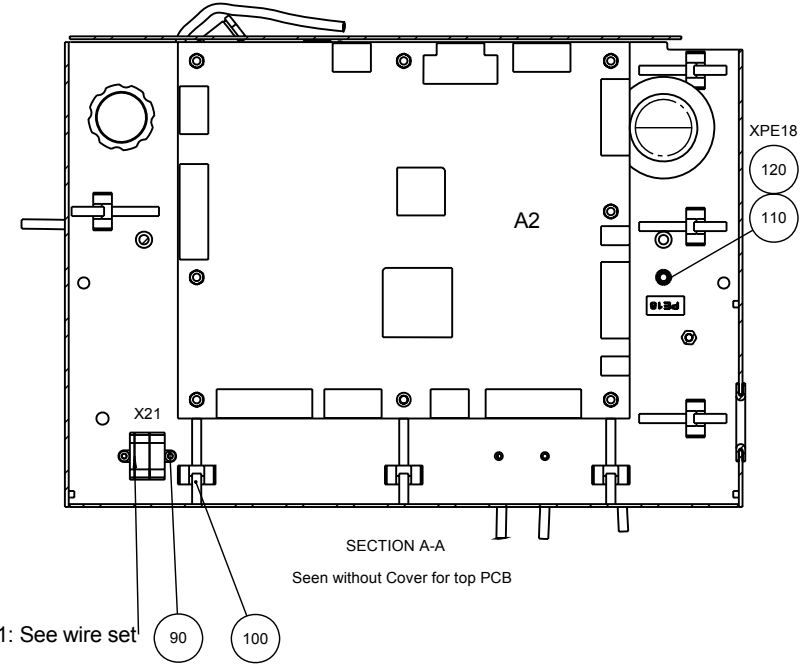
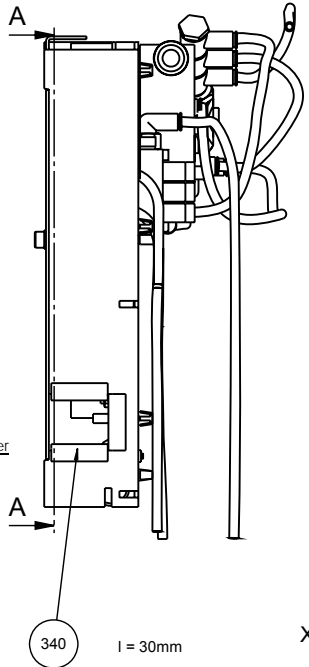
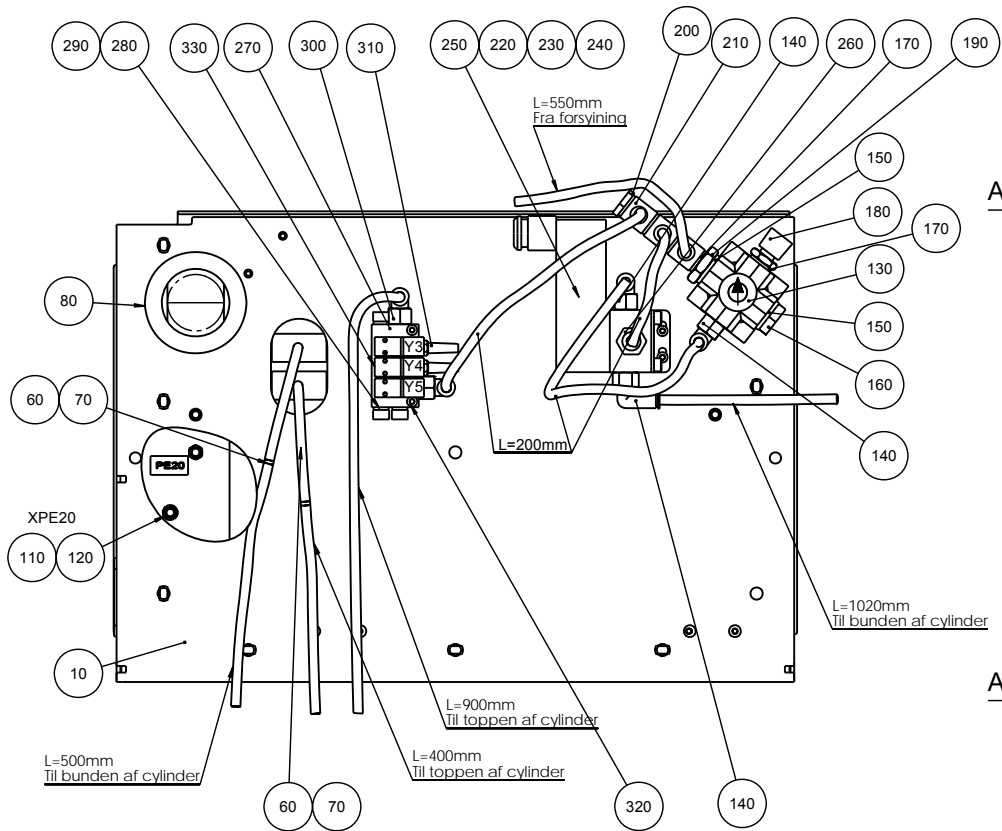

C					
B	12.09.2007	Pos. 140 have changed place with 180.	SPE	12.09.2007	
A	30-11-2006		YKJ		
Revision	Crea. date dd-mm-yy	Revision description	Draw. Init	Appr. date dd-mm-yy	Appr. Init
		Material:	Scale: 1:2	Format: A2	Tolerance: DS/ISO 2768- Surface treat.: mK None
ID:	Description: <b>15880034 W. PCB and pneu. distr., assembly</b>				Rev: <b>B</b>

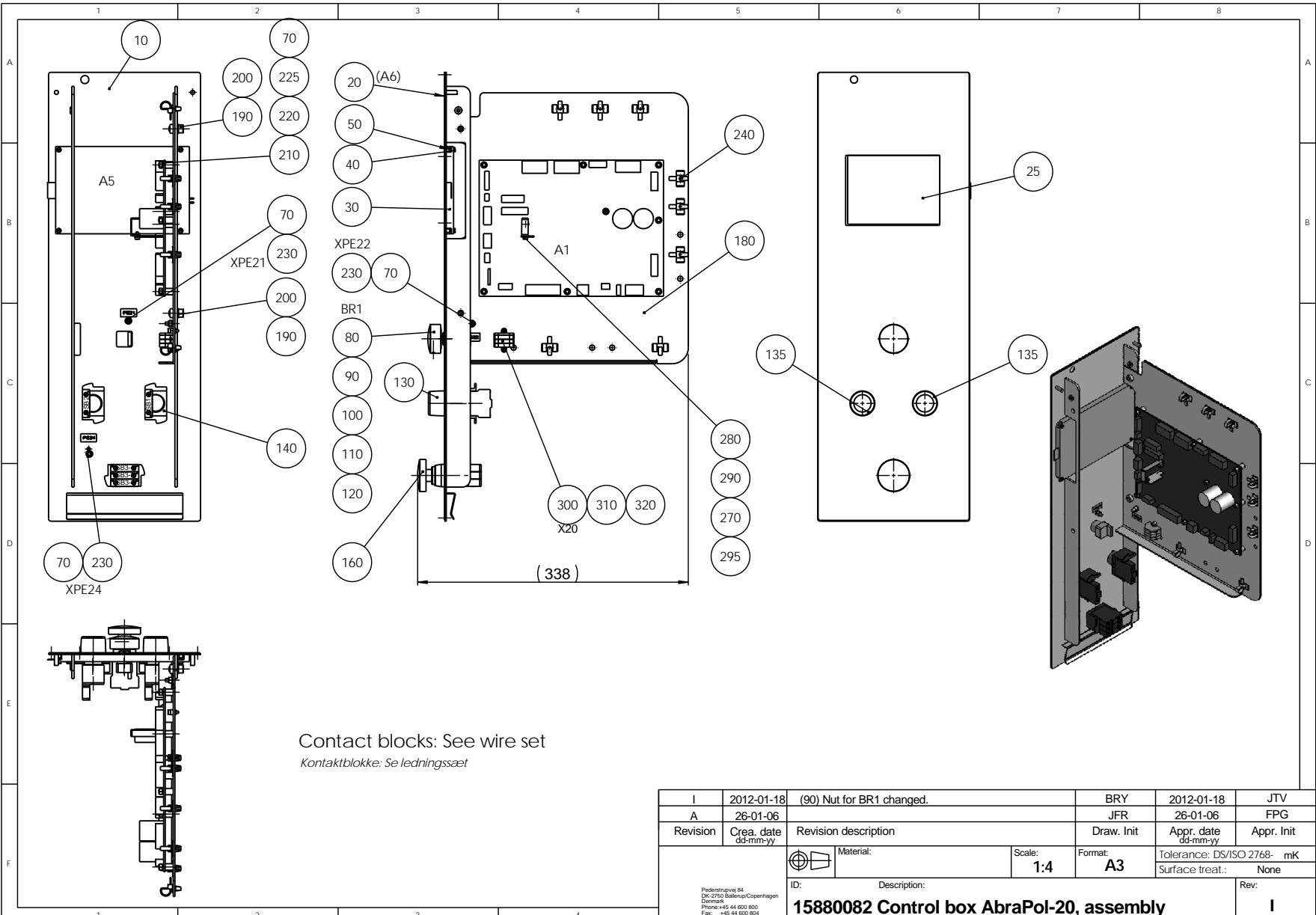

Contact blocks: See wire set  
 Kontaktblokke: Se ledningssæt

I	2012-01-18	(90) Nut for BR1 changed.	BRY	2012-01-18	JTV
A	26-01-06		JFR	26-01-06	FPG
Revision	Crea. date dd-mm-yy	Revision description	Draw. Init	Appr. date dd-mm-yy	Appr. Init
		Material:	Scale: <b>1:4</b>	Format: <b>A3</b>	Tolerance: DS/ISO 2768- Surface treat.: mK None
ID:		Description: <b>15880082 Control box AbraPol-20, assembly</b>			Rev: <b>I</b>

Pedersbølvej 84  
 DK-2750 Ballerup/Copenhagen  
 Denmark  
 Phone: +45 44 600 800  
 Fax: +45 44 600 804

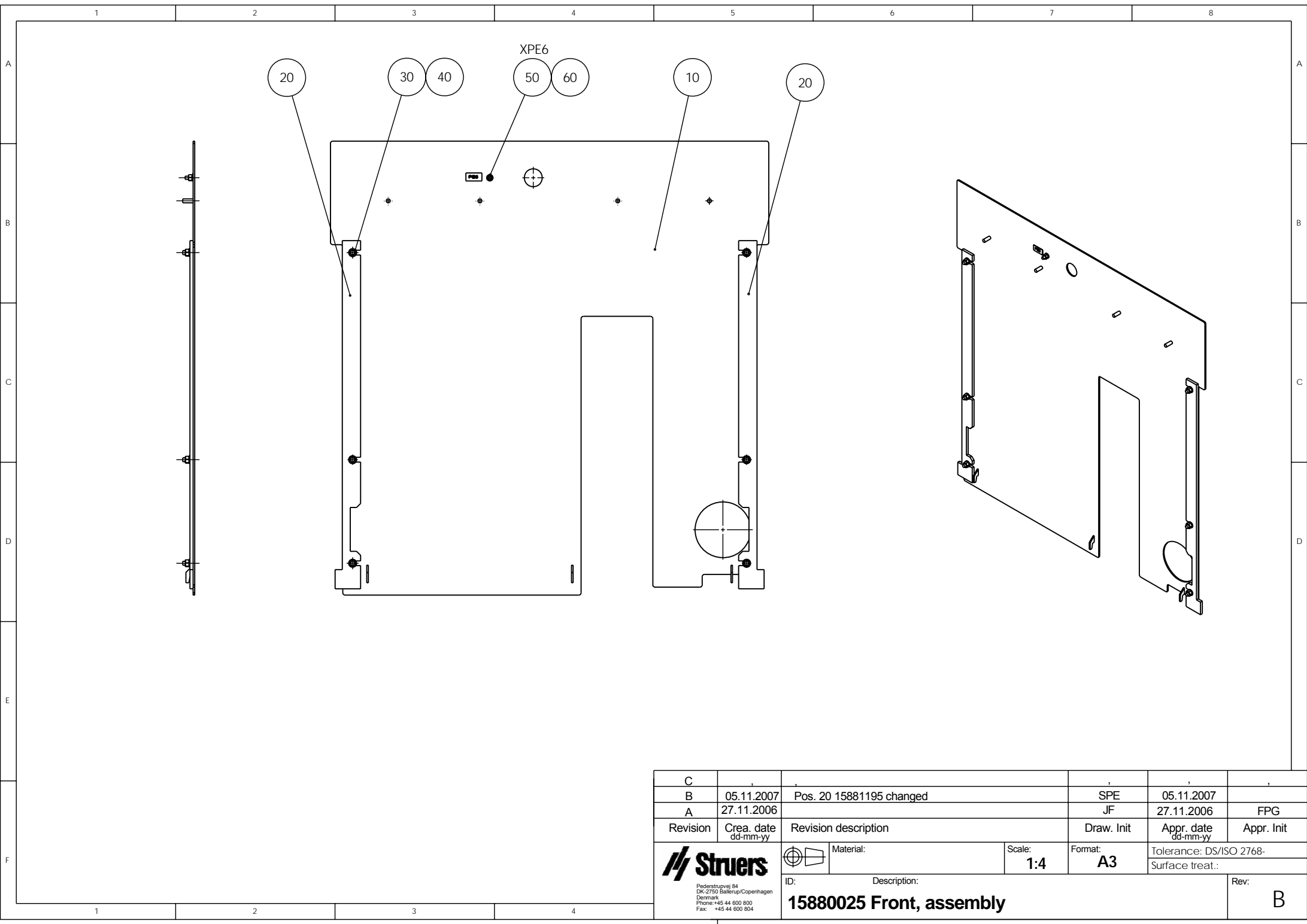

C					
B	05.11.2007	Pos. 20 15881195 changed	SPE	05.11.2007	
A	27.11.2006		JF	27.11.2006	FPG
Revision	Crea. date dd-mm-yy	Revision description	Draw. Init	Appr. date dd-mm-yy	Appr. Init
		Material:	Scale: <b>1:4</b>	Format: <b>A3</b>	Tolerance: DS/ISO 2768- Surface treat.:
ID:	Description:				Rev:
	<b>15880025 Front, assembly</b>				<b>B</b>



Pederstrupvej 84  
DK-2750 Ballerup/Copenhagen  
Denmark  
Phone: +45 44 600 800  
Fax: +45 44 600 804



Material:

Scale:

**1:4**

Format:

**A3**

Tolerance: DS/ISO 2768-  
Surface treat.:

ID: Description:

**15880025 Front, assembly**

Rev:

**B**



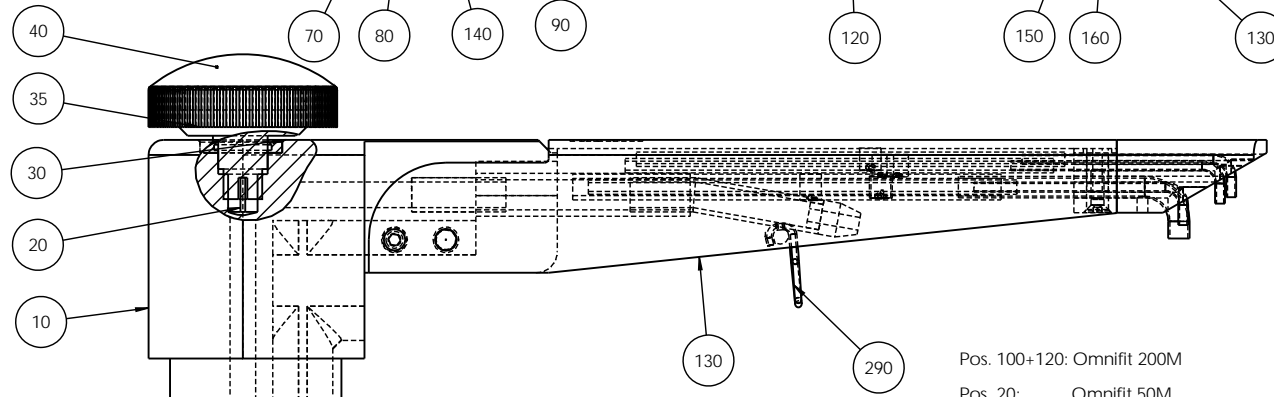
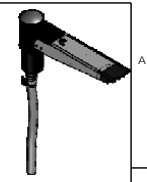
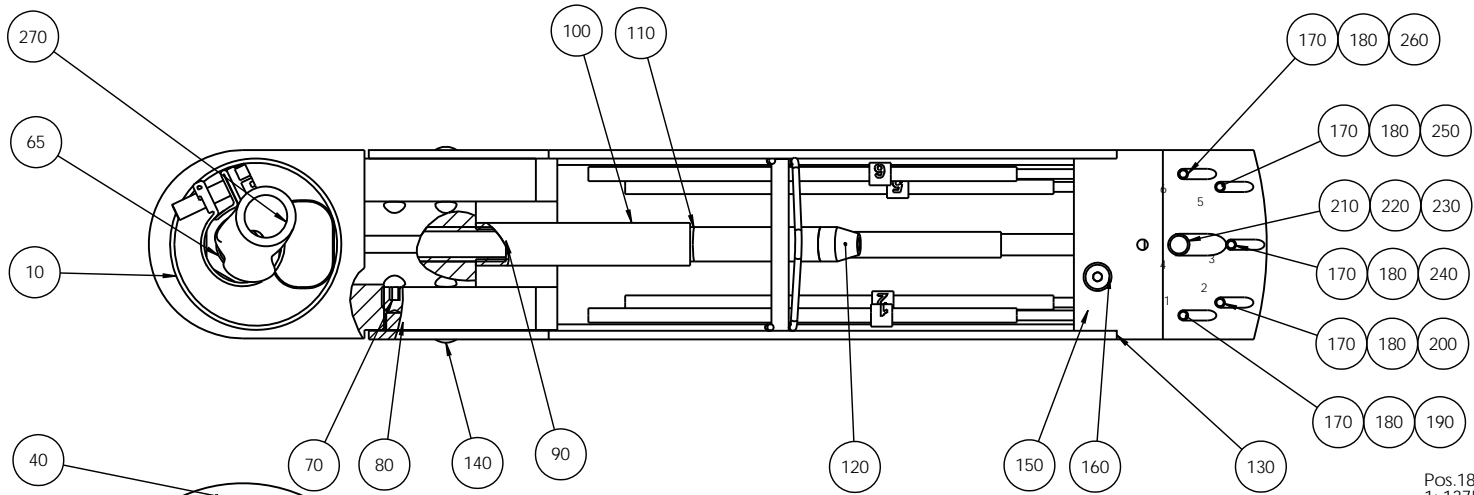

Pos. 180 Slangelængder:  
 1: 1375mm  
 2: 1305mm  
 3: 1230mm

5: 1110mm  
 6: 1010mm

Pos. 220 Slangelængder:  
 4: 1150mm

- Pos. 100+120: Omnifit 200M
- Pos. 20: Omnifit 50M
- Pos. 35: High Vacuum Grease på gevind og ø14.
- Pos. 90: Omnifit eal 50H

E	2012.09.18	2NS11709->2NS14169	SPE	2012.09.18	
A	27.01.2000		rje	11.03.2000	KLB
Revision	Crea. date yyy-mm-dd	Revision description	Draw. Init	Appr. date yyy-mm-dd	Appr. Init
Material:		Scale: 1:1	Format: A3	Tolerance: DS/ISO 2768- mK	g
ID:	Description:		Weight:		
<small>           Pedestrupvej 84            DK-2750 Ballerup/Copenhagen            Denmark            Phone: +45 44 600 800            Fax: +45 44 600 804         </small>		<b>15090055 Doserarm, monteret</b>			Rev: E

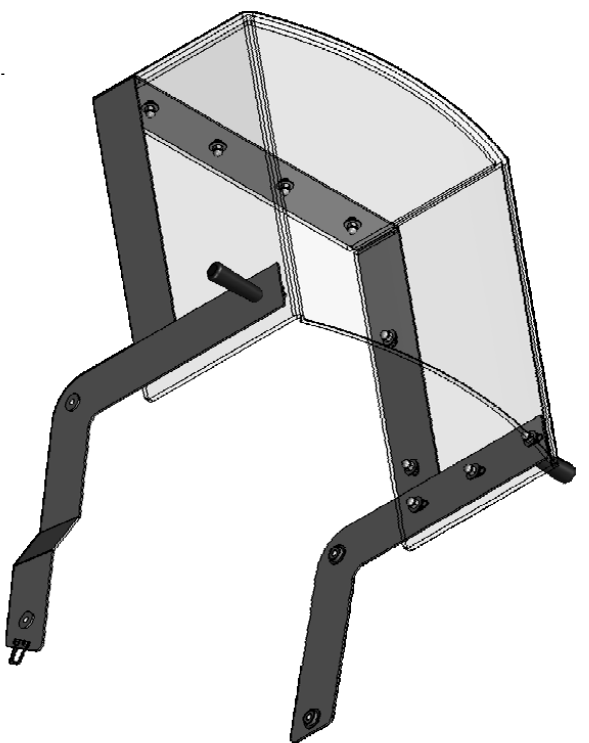
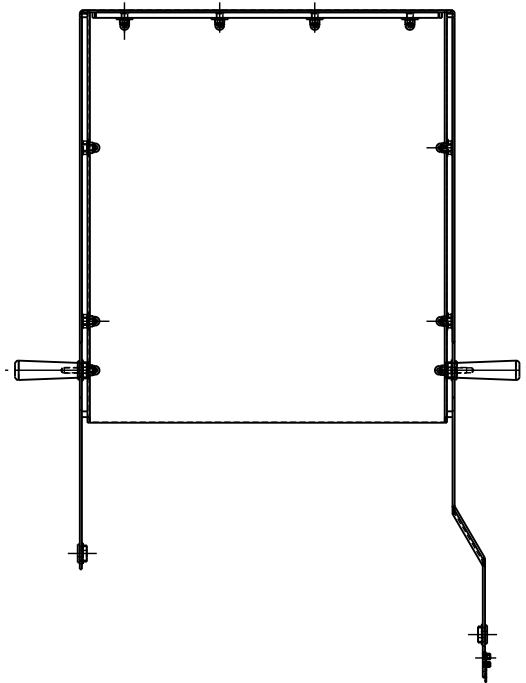
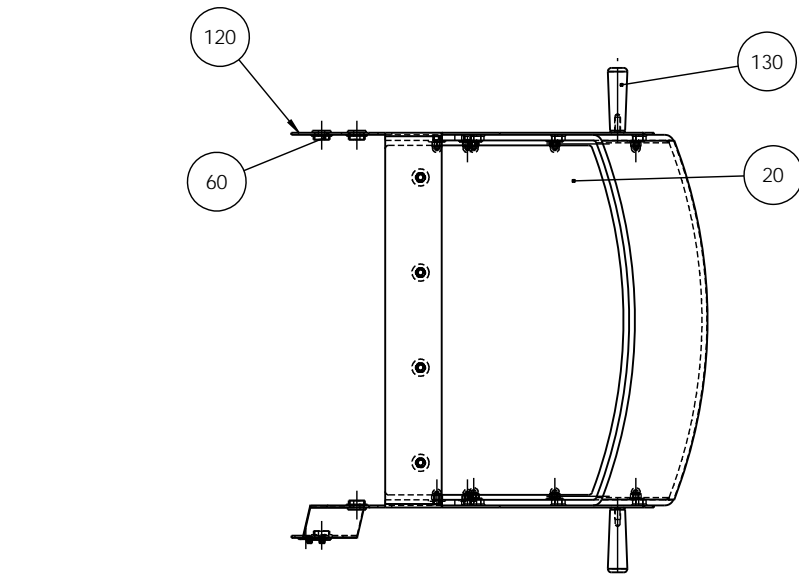
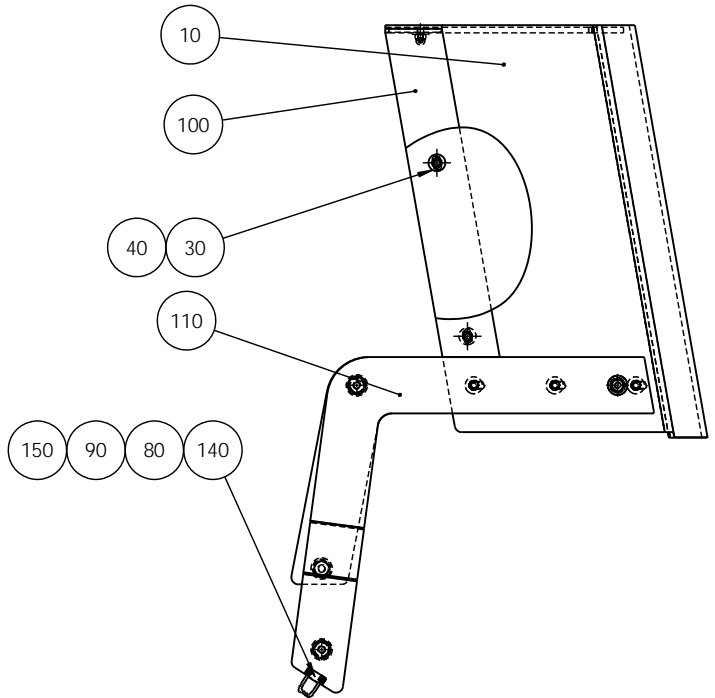

- 40 Clamping torque: 2Nm.  
Use Loctite 243/Omnifit 100M.
- 30 Round edges against plastic.

D	2010-03-16	Text about (30)(40) added.	BRY	2010-03-16	JTV
A	02.02.2006		JF	02.02.2006	FPG
Revision	Crea. date yyyy-mm-dd	Revision description	Draw. Init	Appr. date yyyy-mm-dd	Appr. Init
		Material:	Scale: 1:7	Format: A3	Tolerance: DS/ISO 2768- mK Surface treat.: None
		ID:	Description:		Rev:
<small>Pæderstrupvej 84 DK-2750 Ballerup/Copenhagen Denmark Phone: +45 44 600 800 Fax: +45 44 600 804</small>		<b>15890080 Safety guard, assembly</b>			<b>D</b>

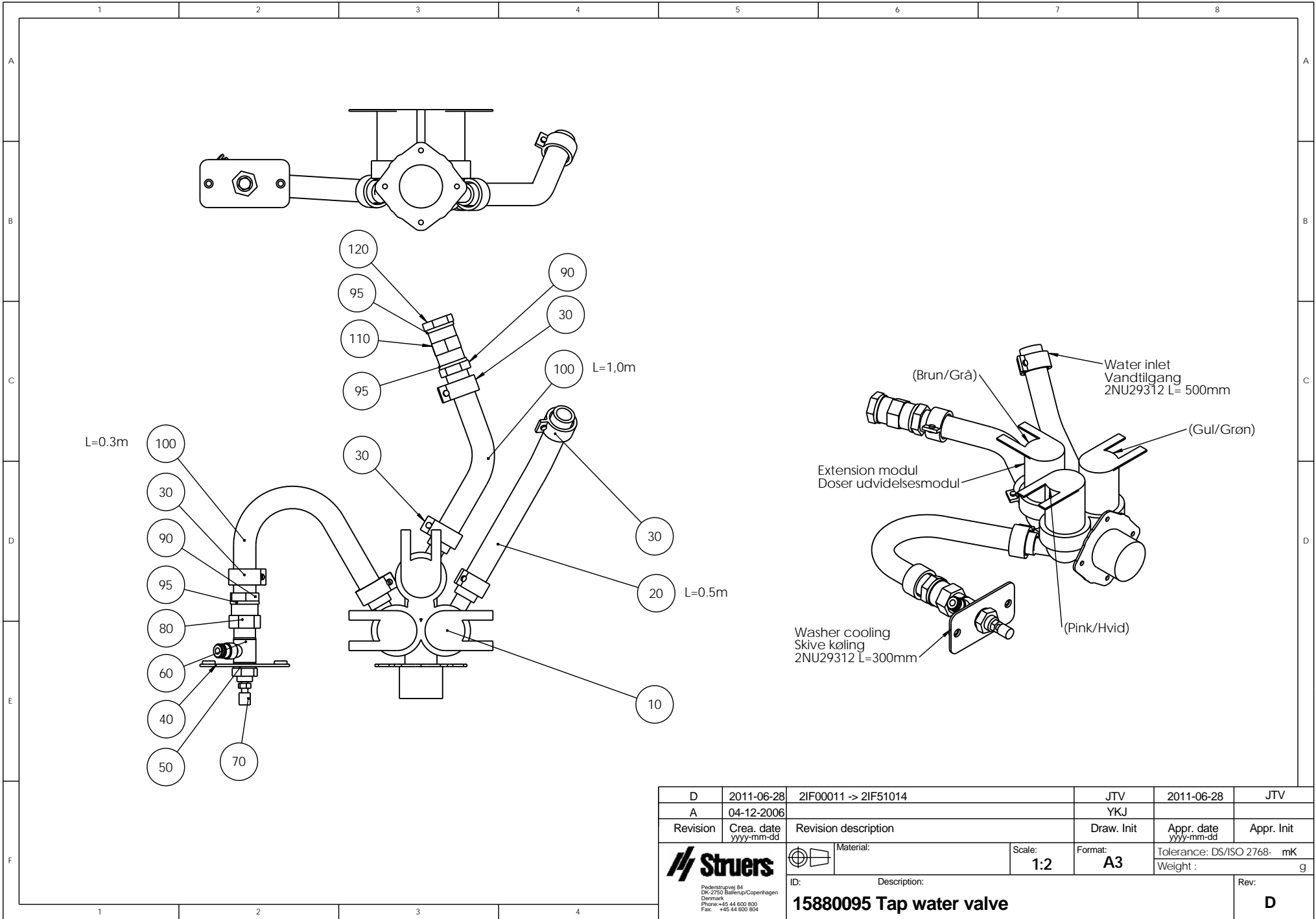

D	2011-06-28	2IF00011 -> 2IF51014	JTV	2011-06-28	JTV
A	04-12-2006		YKJ		
Revision	Crea. date yyyy-mm-dd	Revision description	Draw. Init	Appr. date yyyy-mm-dd	Appr. Init
		Material:	Scale: 1:2	Format: A3	Tolerance: DS/ISO 2768- mK
		Description:	Weight :		g
<b>15880095 Tap water valve</b>					Rev: <b>D</b>

**Struers**  
 Pedestrupvej 84  
 DK-2750 Ballerup/Copenhagen  
 Denmark  
 Phone: +45 44 600 800  
 Fax: +45 44 600 804

Venstre rude

Højre rude

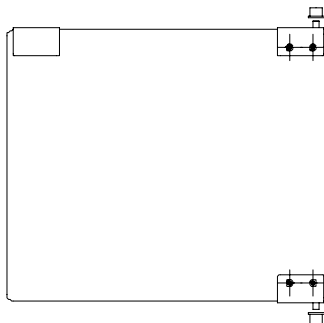
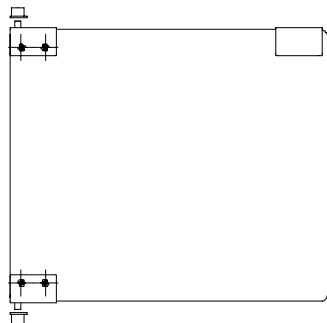

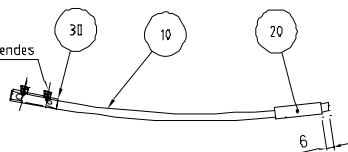

Bøsning placeres i kabinnet for afløbsskar

Medfølgende skruer anvendes



30 Justeres ved montagen.

Matr.:	Overfl. beh.:	Måkerkædt:	Ikke ang. tol. afLÆR DS/ISO 2768-	
	Prejektionsmetode: 	1:2.5	Dato	Sign.
			Tegn. 160300	BWJ
Ruder for dosermadul, mont.			Kont. 180700	KLB
Eneb.:			15090004	

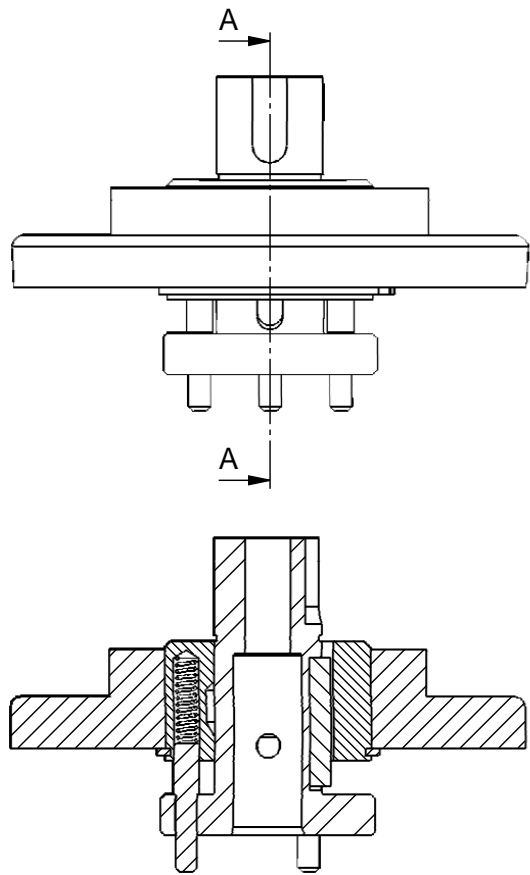

SECTION A-A

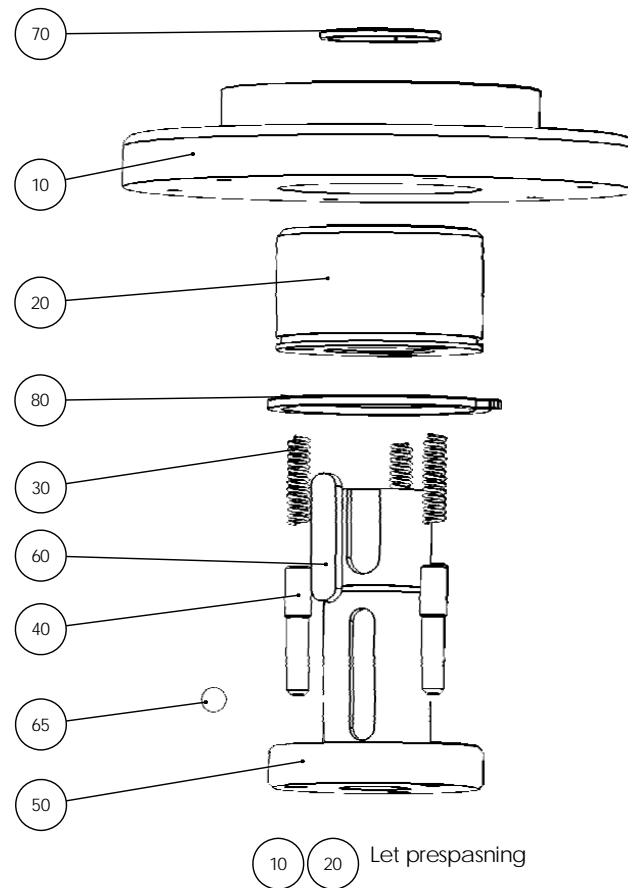

10 20 Let prespasning

POS. NO.	AMOUNT	DRAW. NO.	NAME	NOTE
10	1	12600711	Tryksko	
20	1	15490430	Styr	
30	3	12600718	Trykfjeder d4.3x0.7	
40	3	12600717	Medbringertap	
50	1	15490400	Aksel	
60	1	12600723	Feder	
65	2	2BA00055	Kugle KU 5,556 ø7 Rustfri	
70	1	2ZL30250	Laasering A25 Rustfri DIN471	
80	1	2ZL30480	Laasering A48 Rustfri DIN471	

C	2012.05.15	Drawing updated	TOS	2012.05.15	
A	2001.06.11		BMJ	2001.06.11	
Revision	Crea. date yyyy-mm-dd	Revision description	Draw. Init	Appr. date yyyy-mm-dd	Appr. Init
		Material:	Scale: <b>1:1</b>	Format: <b>A3</b>	Tolerance: DS/ISO 2768- Weight :                      g
<small>           Pederstrupvej 84            DK-2750 Ballerup/Copenhagen            Denmark            Phone: +45 44 600 800            Fax: +45 44 600 804         </small>		ID:	Description:		Rev:
<b>15090009 Opspaendingsenhed, monteret</b>					<b>C</b>

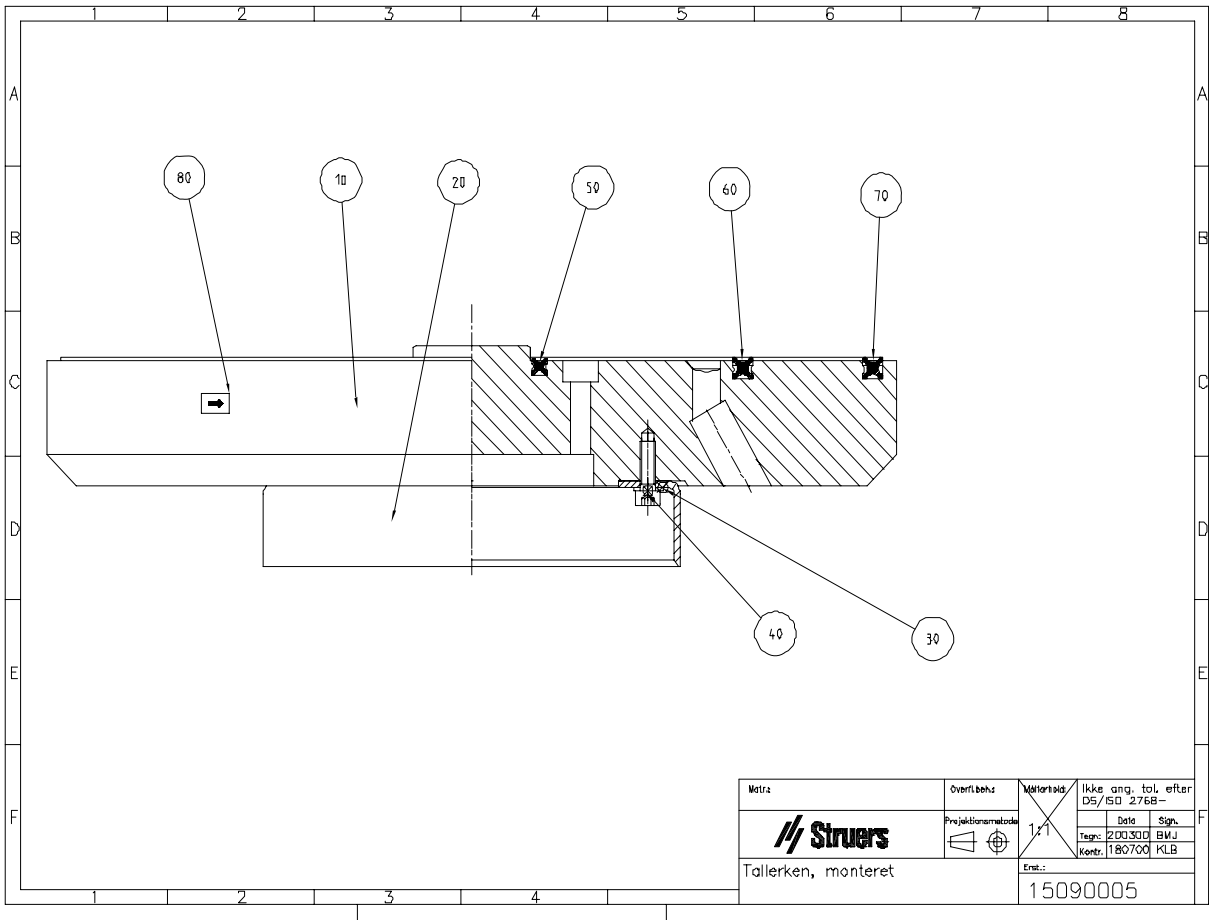

Matr:	Overf. behv:	Material:	Ikke ang. tol. efter DS/ISO 2768-
<b>Struers</b>	Projektionsmetode	1:1	Dato: _____ Tegn: 200300 BMJ Kontr: 180700 KLB
Tallerken, monteret			Erst.: 15090005

1

2

3

4

A

B

C

D

E

F

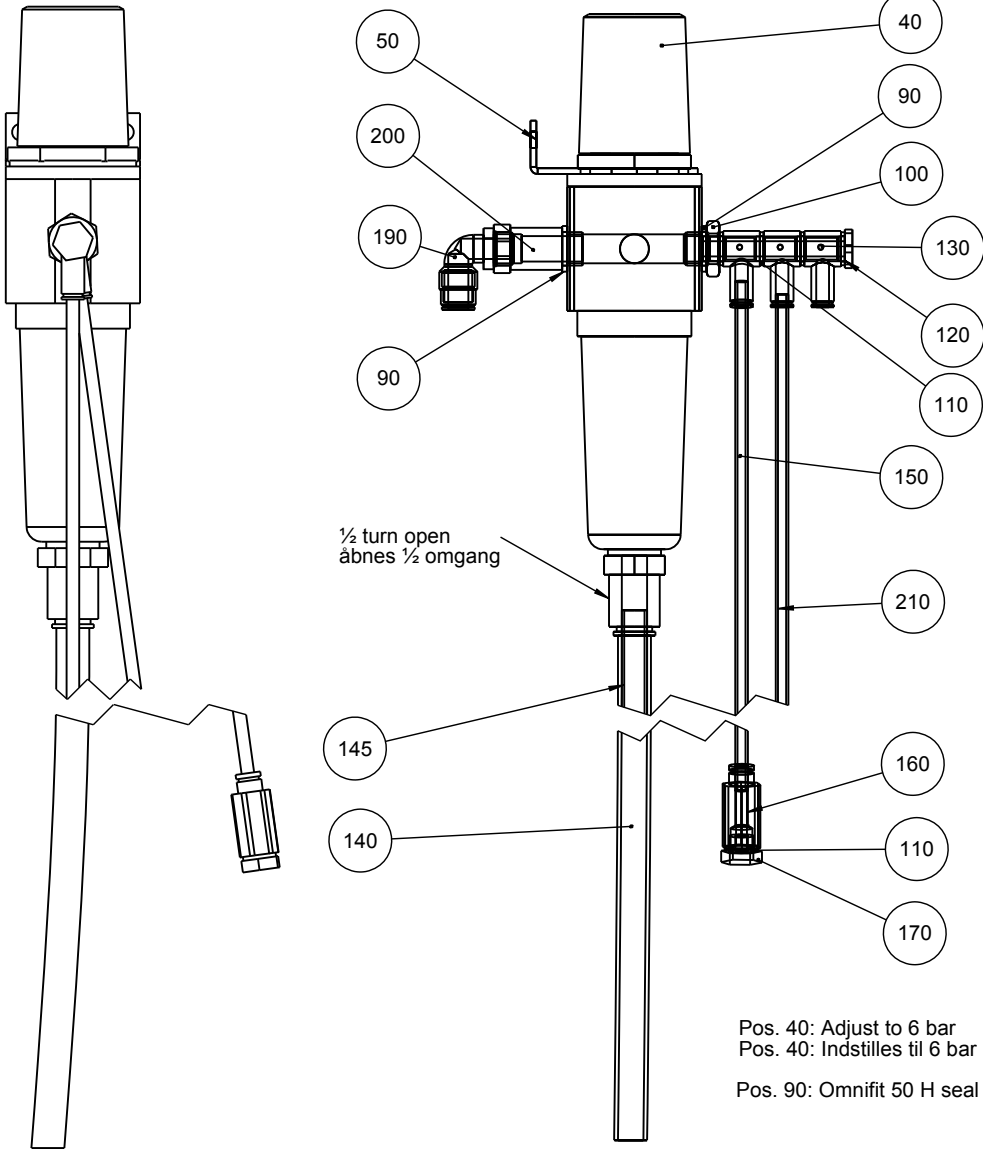

Pos. 40: Adjust to 6 bar  
 Pos. 40: Indstilles til 6 bar

Pos. 90: Omnifit 50 H seal

E	08.09.2008	Pos.210 added, pos. 110+150+160+170 moved.	SPE	08.09.2008	
A	29-02-08		SPE	02-04-07	JTV
Rev	Crea. date dd-mm-yy	Revision description	Draw. Init	Appr. date dd-mm-yy	Appr. Init
<p>Federstrupvej 84        DK-2750 Ballerup        Copenhagen        Denmark        Phone: +45 44600 800        Fax: +45 44600 804</p>	<p>Material:</p>	<p>ID: Description:</p> <p><b>15090032 Air connection, assembled</b></p>	<p>Scale: <b>1:2</b></p>	<p>Format: <b>A4</b></p>	Tolerance: DS/ISO 2768 - mK
					Surface treat.:
					Rev: <b>E</b>

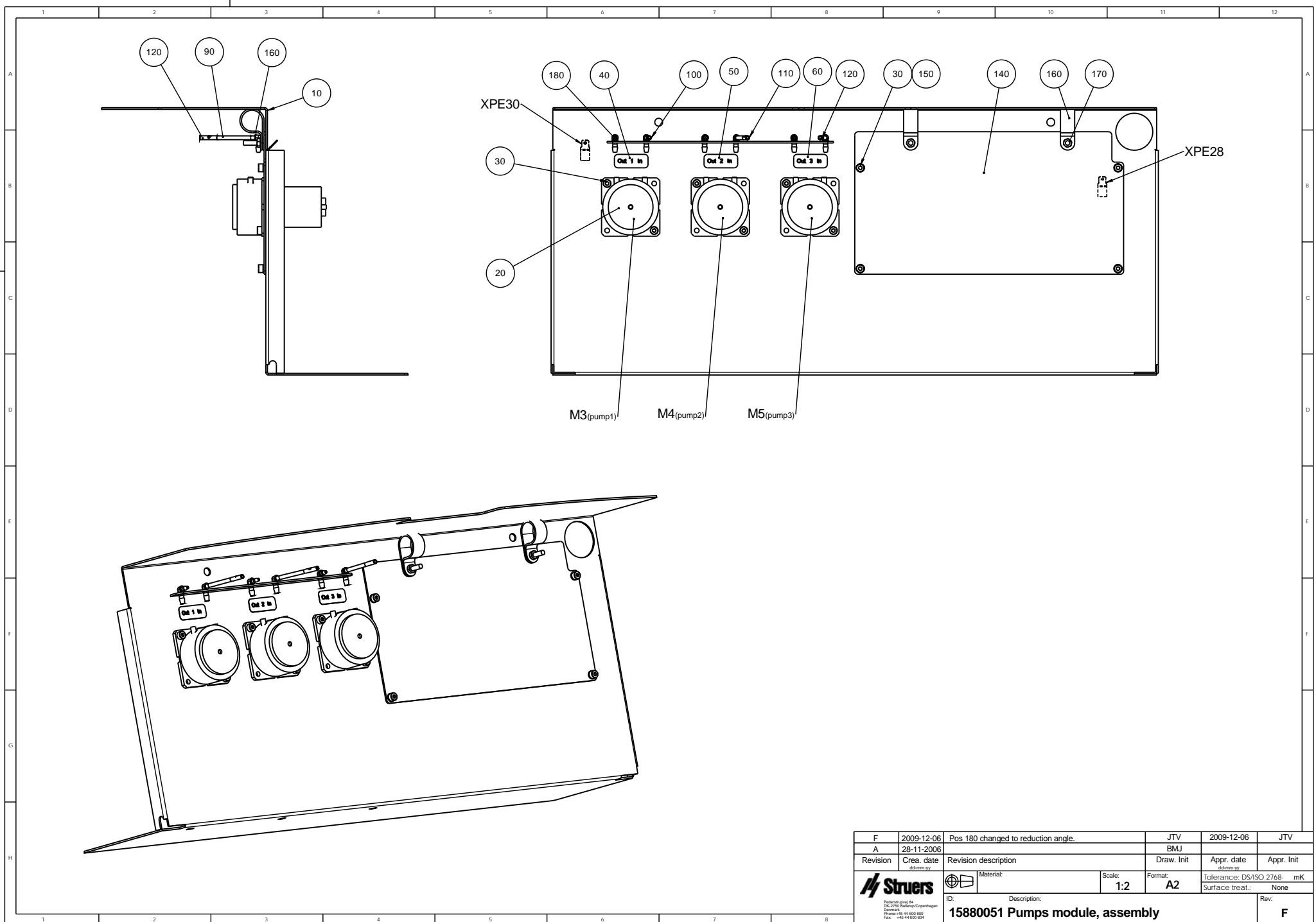

F	2009-12-06	Pos 180 changed to reduction angle.	JTV	2009-12-06	JTV
A	28-11-2006		BMJ		
Revision	Crea. date	Revision description	Draw. Init	Appr. date	Appr. Init
	dd.mm.yy			dd.mm.yy	
			Material:	Scale: 1:2	Format: A2
			Tolerance: DS/ISO 2768- mK		
			Surface treat.: None		
ID: 15880051 Pumps module, assembly			Description:		Rev: F



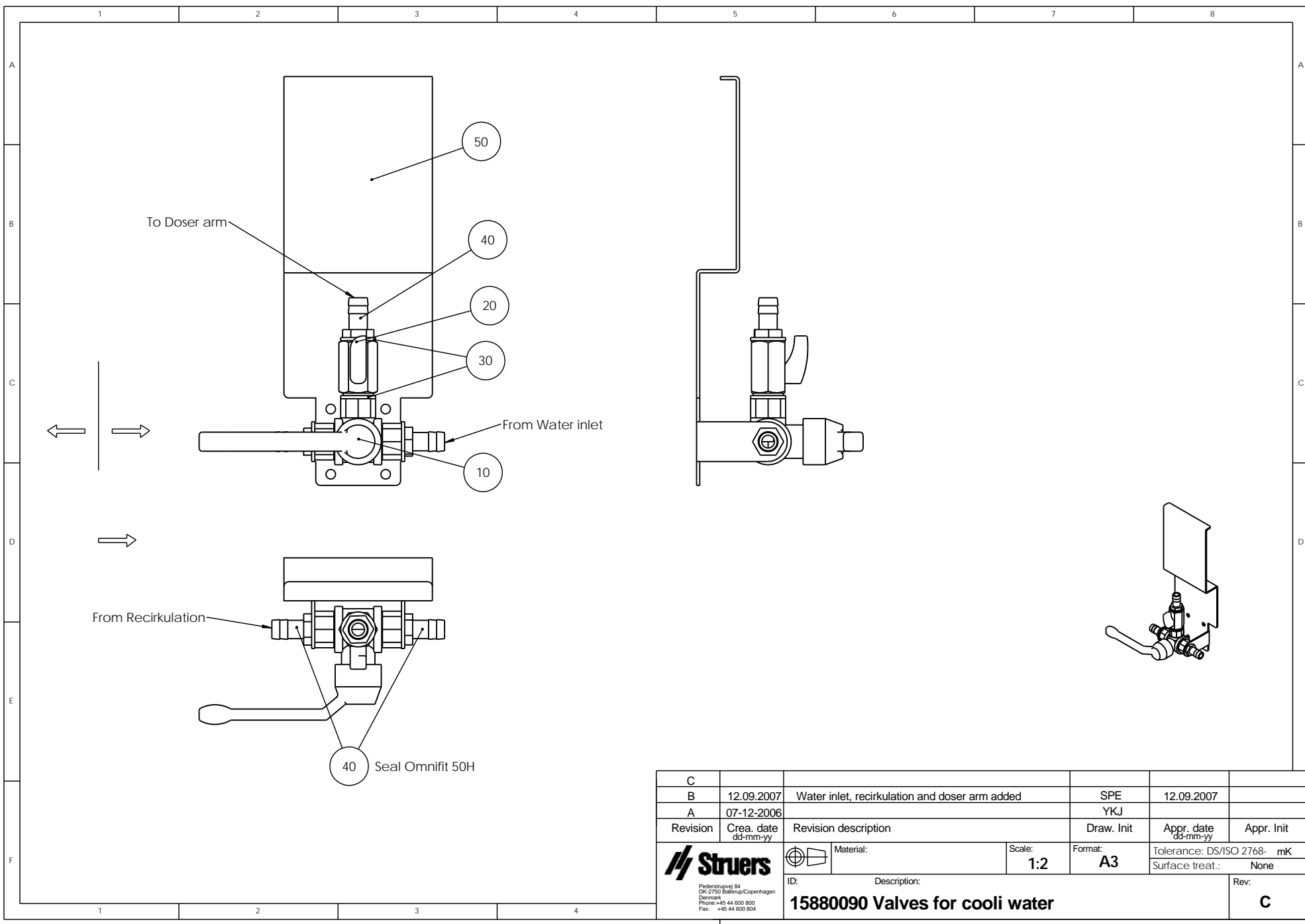

C					
B	12.09.2007	Water inlet, recirkulation and doser arm added	SPE	12.09.2007	
A	07-12-2006		YKJ		
Revision	Crea. date dd-mm-yy	Revision description	Draw. Init	Appr. date dd-mm-yy	Appr. Init
		Material:	Scale: 1:2	Format: A3	Tolerance: DS/ISO 2768- mK Surface treat.: None
ID:	Description:				Rev:
15880090 Valves for cool water					C

Frederiksborgvej 64  
 DK-2750 Ballerup/Copenhagen  
 Denmark  
 Phone: +45 44 600 800  
 Fax: +45 44 600 804

5 4 3 2 1  
**CONNECTION FOR 200V / 50Hz**

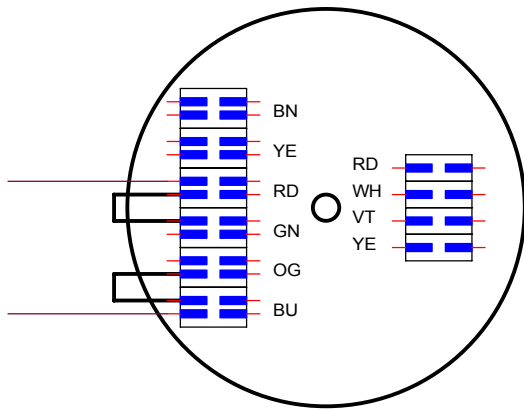

**CONNECTION FOR 200-210V / 60Hz**

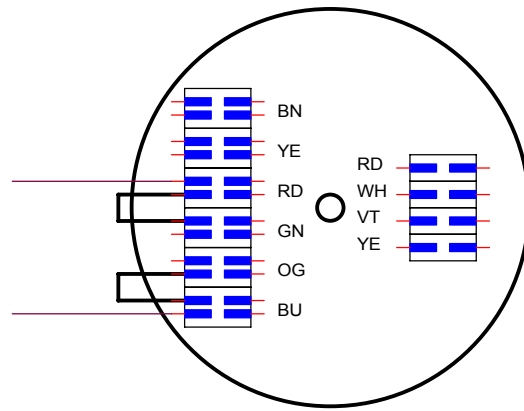

**CONNECTION FOR 220-230V / 50Hz**

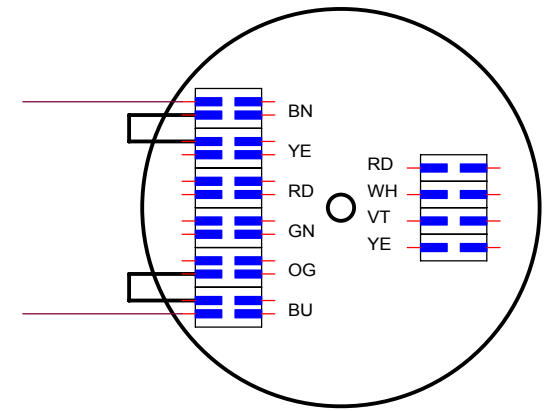

**CONNECTION FOR 220-240V / 60Hz**

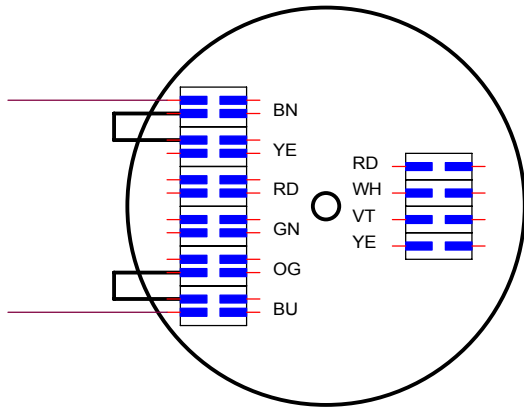

**CONNECTION FOR 380-415V / 50Hz**

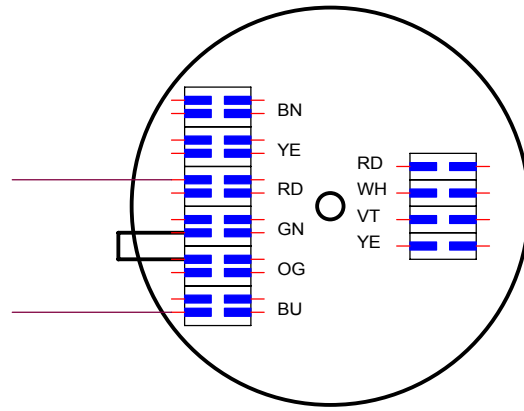

**CONNECTION FOR 380-415V / 60Hz**

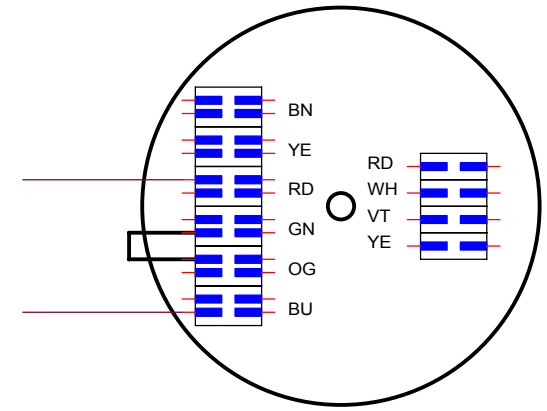

**CONNECTION FOR 430-460V / 60Hz**

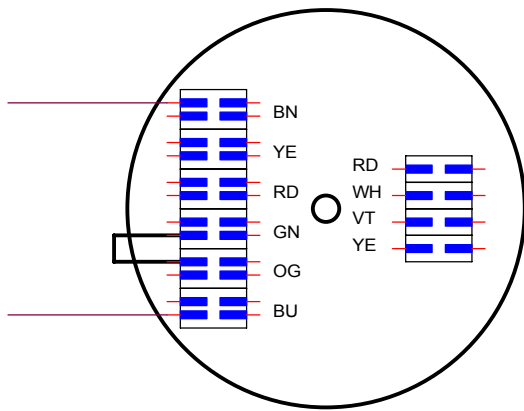

**CONNECTION FOR 460-480V / 60Hz**

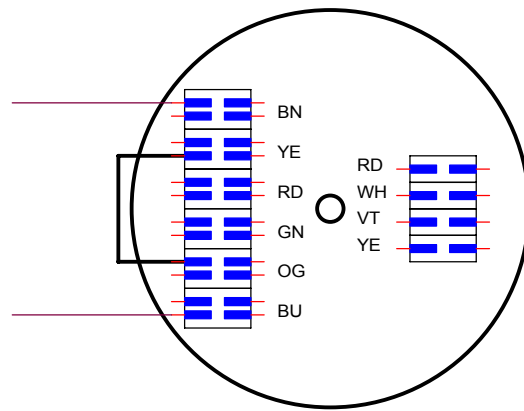

**COLOR CODES:**

- BK = BLACK
- BN = BROWN
- RD = RED
- OG = ORANGE
- YE = YELLOW
- GN = GREEN
- BU = BLUE
- VT = VIOLET
- GY = GREY
- WH = WHITE

Rev. A: Baan PDM		STRUERS A/S VALHOEJS ALLE 1176 DK-2610 ROEDOVRE DENMARK PHONE: + 45 3670 3500		
<b>Transformer connections.</b>				
FILE NAME.: 5093452.DSN PAGE1.SCH	Size A3	CAGE Code <Cage Code>	DWG NO <b>15093452</b>	Rev <b>A</b>
Thursday, September 21, 2000	Scale	SLN / SLN		Sheet 1 of 3

Primær:

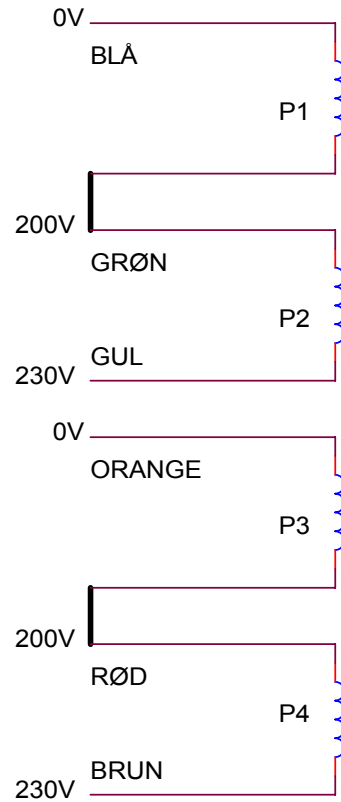

Sekundær:

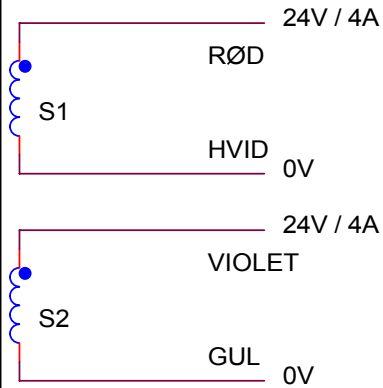

| = intern forbindelse

Rev. A: Baan PDM	STRUERS A/S VALHØJES ALLE 1176 DK-2610 ROEDOVRE DENMARK PHONE: + 45 3670 3500			
	Transformator Construction - electrical			
FILE NAME.: 5093452.DSN PAGE2.SCH	Size A4	CAGE Code <Cage Code>	DWG NO <b>15093452</b>	Rev <b>A</b>
Thursday, September 21, 2000	Scale	<b>SLN / SLN</b>	Sheet 2 of 3	

A

B

C

D

E

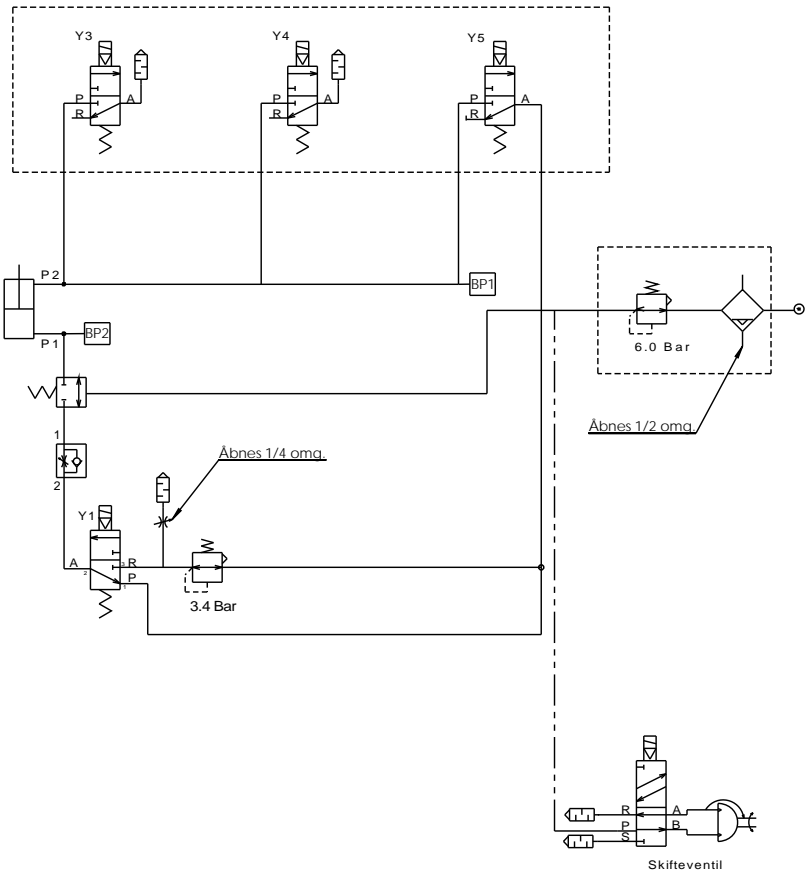

C	2011-06-08	Speed adjustment valve added	JTV	2011-06-08	JTV
A	18.11.2006		JF	18.11.2006	FPG
Rev	Crea. date	Revision description	Draw. Init	Appr. date	Appr. Init
	yyyy-mm-dd			yyyy-mm-dd	



Pederstrupvej 84  
DK-2750 Ballerup  
Copenhagen  
Denmark  
Phone : +45 44600 800  
Fax : +45 44600 804



Material:

Scale:  
**1:1**

Format:  
**A4**

Tolerance: DS/ISO 2768 -  
Surface treat.:

ID: Description:  
**15882000 Air diagram AbraPol-20**

Rev:  
**C**

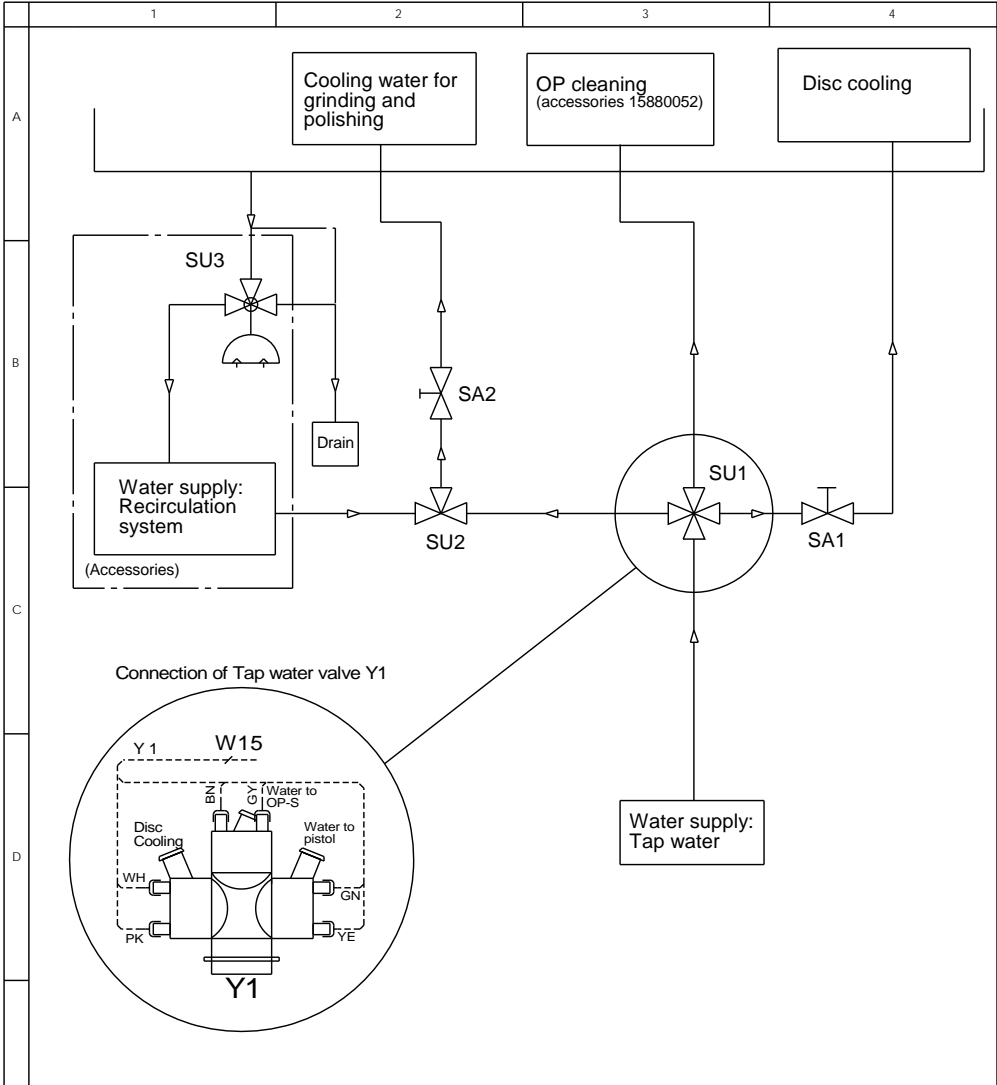

SA1 Throttle-valve (Assy:15880095, part: 2YH00008) for regulation of inflow water for disc cooling (Assy:15880058)  
 SA2 Throttle-valve (Assy:15880090, part: 2YH10602) for regulation of inflow water for water pistol (Assy:15880055)  
 SU1 Three-way electromagnetic valve (Assy: 15880095, part: 2YH12311)  
 SU2 Three-way spherical valve (Assy: 15880090, part: 2YH03629)  
 SU3 Three-way air actuator driven valve: 15880080

B	2010-03-12	SU3 added to diagram	JTV	2010-03-12	JTV
A	15.8.2007		JF	15.8.2007	MD
Rev	Crea. date yyyy-mm-dd	Revision description	Draw. Init	Appr. date yyyy-mm-dd	Appr. Init

<p>Pederstrupvej 84 DK-2750 Ballerup Copenhagen Denmark Phone :+45 44600 800 Fax : +45 44600 804</p>	Material:	Scale: <b>1:1</b>	Format: <b>A4</b>	Tolerance: DS/ISO 2768 - Surface treat.:
	ID: Description: <b>15882005 Water connection diagram AbraPol-20</b>			Rev: <b>B</b>

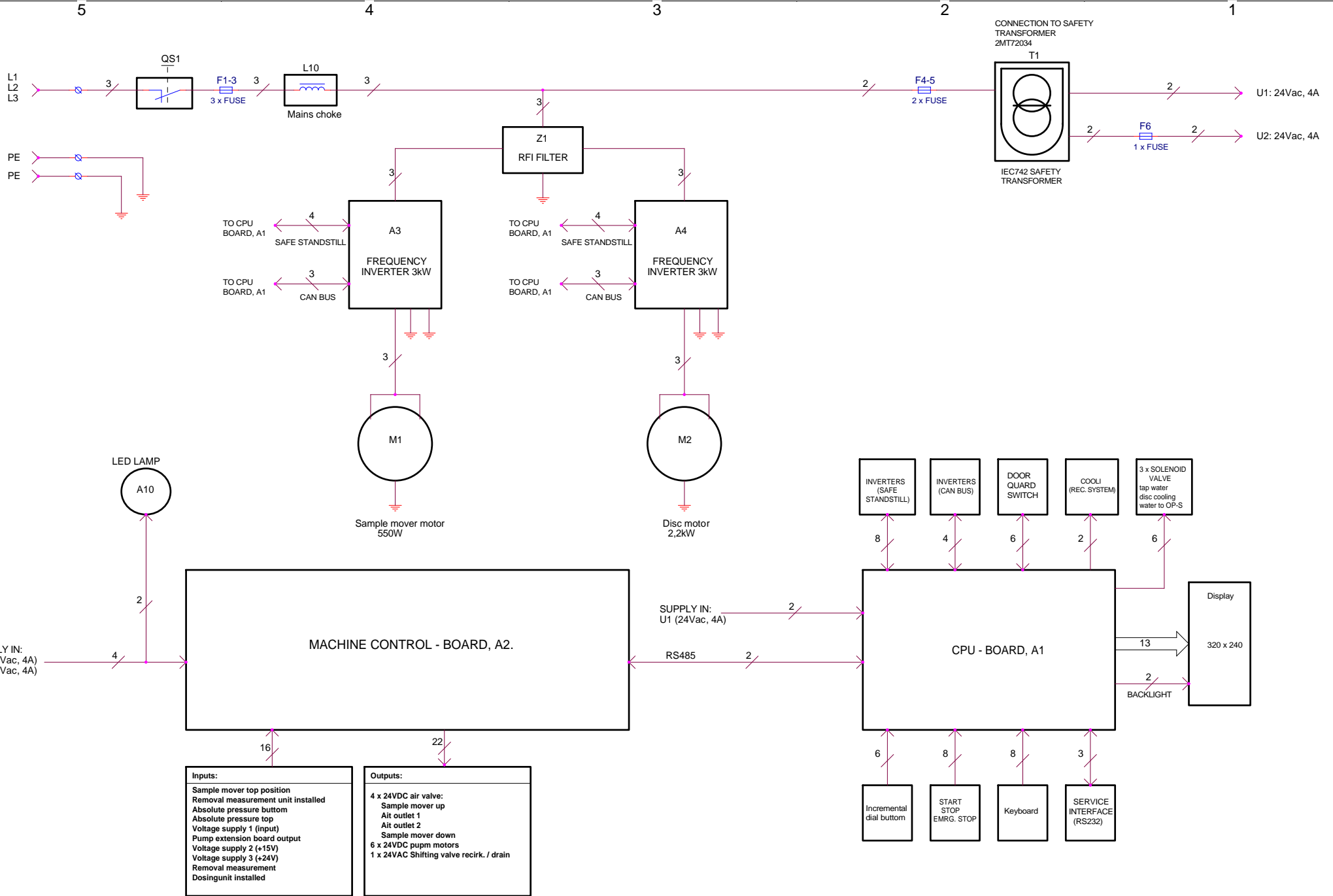

REV A: OH (2006/10/23)	STRUERS A/S Fæderstrupvej 84 DK-2750 Ballerup Denmark		
REV B: OH (2007/03/29)	<b>ABRAPOL-20, BLOCK DIAGRAM</b>		
REV C: OH (2007/07/27)			
REV D: OH (2008/11/20)	Size A2	CAGE Code	DWG NO <b>15883050</b>
REV E: TKO (2009-05-11) - A10 added	Scale	OH	Sheet 1 of 1
Monday, May 11, 2009			

SEE REQUIREMENTS FOR MAINS CABLE (EU or UL/CSA) - note #1

MUST BE EXTERNALLY FUSED  
Fmax: See note #2

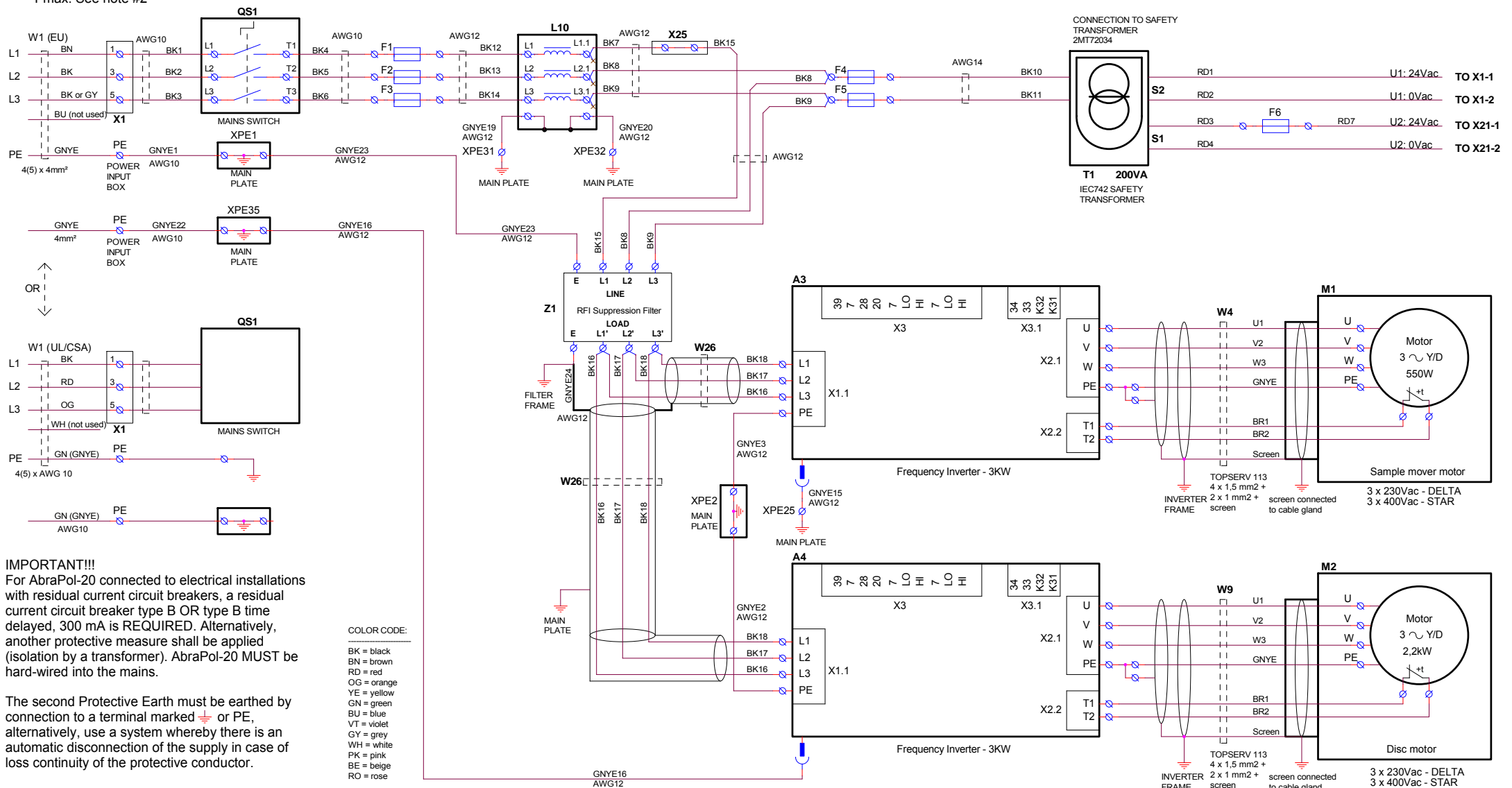

COLOR CODE:  
BK = black  
BN = brown  
RD = red  
OG = orange  
YE = yellow  
GN = green  
BU = blue  
VT = violet  
GY = grey  
WH = white  
PK = pink  
BE = beige  
RO = rose

**IMPORTANT!!!**  
For AbraPol-20 connected to electrical installations with residual current circuit breakers, a residual current circuit breaker type B OR type B time delayed, 300 mA is REQUIRED. Alternatively, another protective measure shall be applied (isolation by a transformer). AbraPol-20 MUST be hard-wired into the mains.

The second Protective Earth must be earthed by connection to a terminal marked PE, alternatively, use a system whereby there is an automatic disconnection of the supply in case of loss continuity of the protective conductor.

VOTAGE / FREQ. (from nameplate)	VOTAGE / FREQ. (depending on country)	note #1 W1 - mains cable	note #2 max. ext. fuse	F1+F2+F3 (fuse size) See note #3	F4+F5 (fuse size) See note #3	F6 (fuse size)	M1+M2 Connection
3 x 200-210V 50/60Hz	3 x 200V / 50Hz	4mm <sup>2</sup>	3 x 50AT	3 x 20AT (CC)	2AT (CC)	4AT	DELTA
	3 x 200-210V / 60Hz	AWG = 10	3 x 50AT	3 x 20AT (CC)	2AT (CC)	4AT	DELTA
3 x 220-240V 50/60Hz	3 x 220-230V / 50Hz	4mm <sup>2</sup>	3 x 50AT	3 x 20AT (CC)	2AT (CC)	4AT	DELTA
	3 x 220-240V / 60Hz	AWG = 10	3 x 50AT	3 x 20AT (CC)	2AT (CC)	4AT	DELTA
3 x 380-415V 50/60Hz	3 x 380-415V / 50Hz	4mm <sup>2</sup>	3 x 50AT	3 x 16AT (aM)	1AT (aM)	4AT	STAR
	3 x 380-415V / 60Hz	AWG = 10	3 x 50AT	3 x 16AT (aM)	1AT (aM)	4AT	STAR
3 x 460-480V 60Hz	3 x 460-480V / 50Hz	4mm <sup>2</sup>	3 x 50AT	3 x 15AT (CC)	1AT (CC)	4AT	STAR
	3 x 460-480V / 60Hz	AWG = 10	3 x 50AT	3 x 15AT (CC)	1AT (CC)	4AT	STAR

Note #3:  
F1, F2, F3, F4, F5 are time delay fuses  
CC...Class-CC characteristic  
aM...aM characteristic

REV E: OHO (2008/11/20)  
- Z1, GNYE23, GNYE24, W26 added  
- BK7, BK8, BK9 for con. L10-A3 removed  
- connection with BK16, BK17, BK18 added  
- BK15, BK8, BK9 reconnected

REV A: OH (2006/10/06)  
REV B: OH (2007/01/24)  
- max. value for ext. fuse changed  
- fuses F1-F5 changed  
REV C: OH (2007/03/29)  
- variants of mains cable added  
- L10, X25 added -> changed connections  
- BK15, BK13, BK14, BK15 added  
- XPE31, XPE32, GNYE19, 20 added  
REV D: OH (2007/07/31)  
- PE, XPE35 and GNYE22 added  
- XPE28 removed, GNYE16 reconnected

STRUERS A/S Pederstrupvej 84 DK-2750 Ballerup Denmark		<b>ABRAPOL-20, CIRCUIT DIAGRAM - MAIN VOLTAGE</b>	
Size A2	CAGE Code	DWG NO <b>15883100</b>	Rev I E
Scale	OHO	Sheet	1 of 1

A1

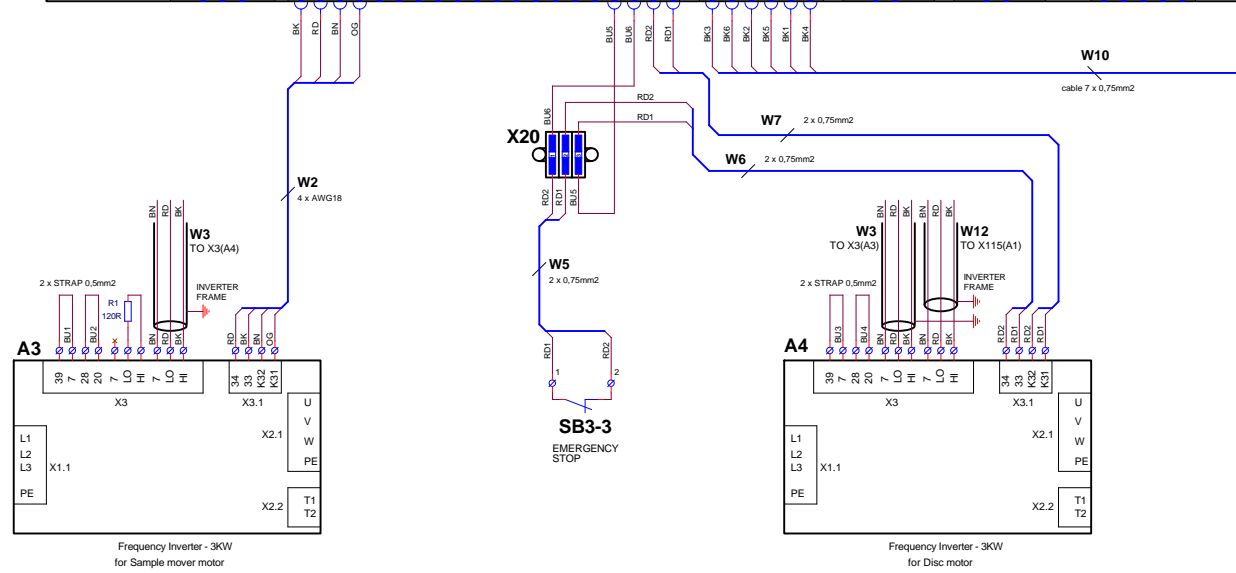
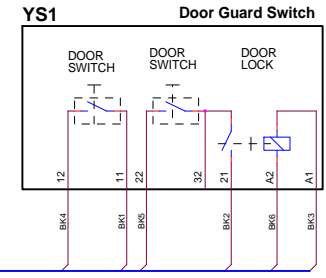
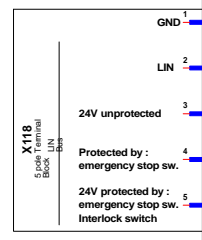
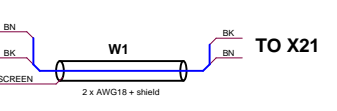
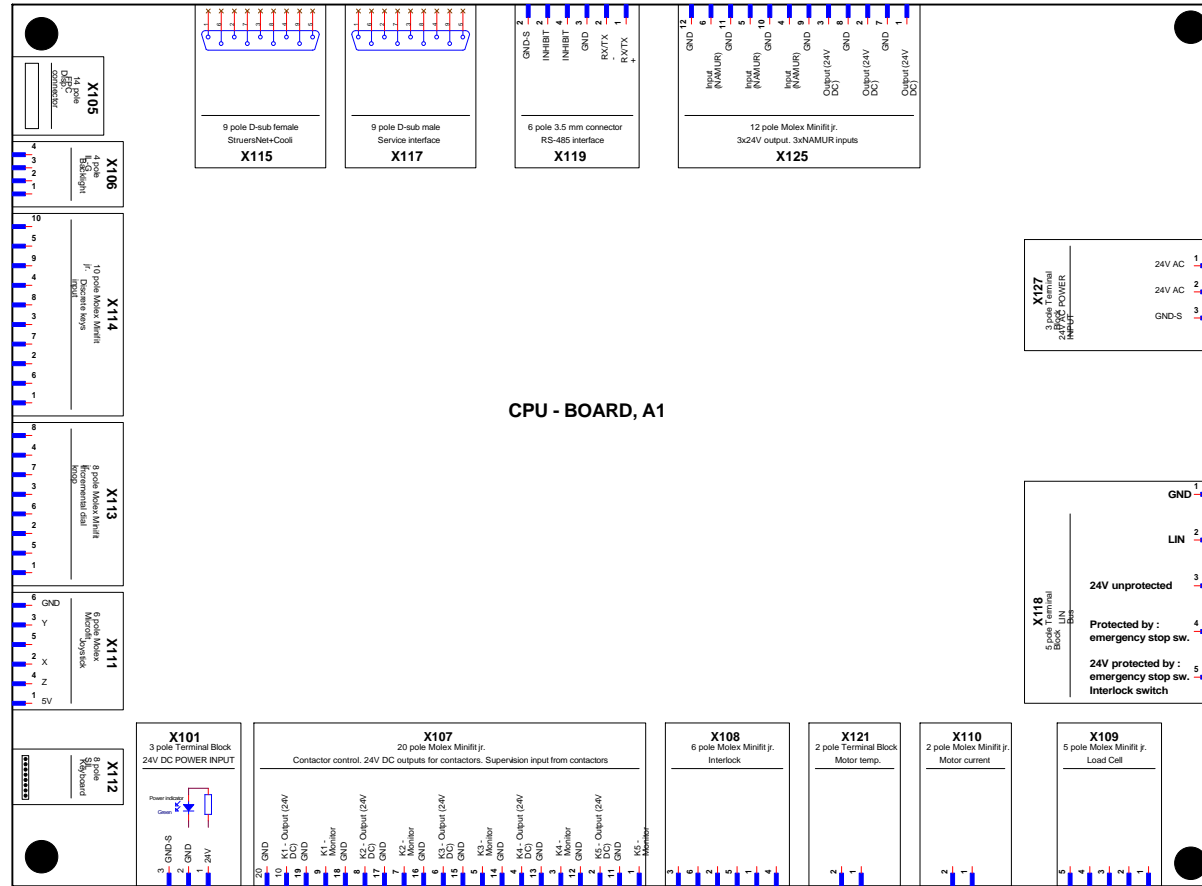

- COLOR CODE:**
- BK = black
  - BN = brown
  - RD = red
  - OG = orange
  - YE = yellow
  - GN = green
  - BU = blue
  - VT = violet
  - CV = grey
  - WH = white
  - PK = pink
  - BE = beige
  - RO = rose
  - GNYE = yellow-green

REV. A: CH (2006/10/08) REV. B: CH (2007/01/04) - W12 removed to W12 - W10 changed REV. C: CH (2007/07/27) REV. D: CH (2007/07/27) REV. E: CH (2007/07/27) REV. F: CH (2007/07/27) www.chenghe.com	STRALERS A/S Fruerholmen 64 DK-2700 Ballerup Denmark	<b>ABRAPOL-20, CIRCUIT DIAGRAM CPU - BOARD, A1 (part 1)</b>
Rev: A1	Page Code: CH	Draw No: 15883120
Scale:	Sheet: 1	of 5





5

4

3

2

1

FILTER Z1

INVERTER A4

INVERTER A3

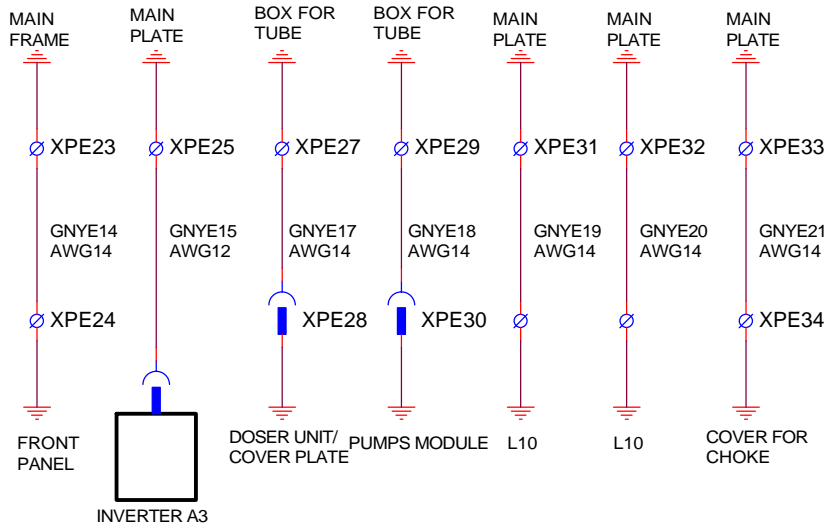
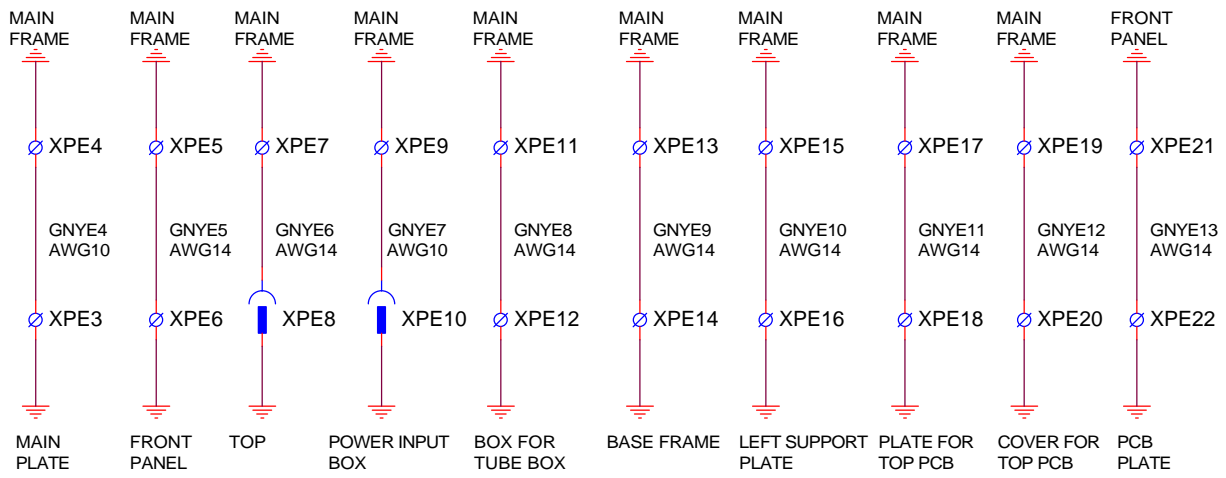
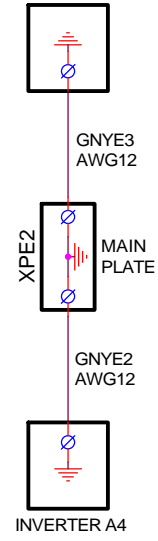
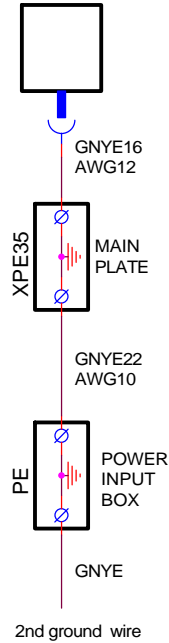
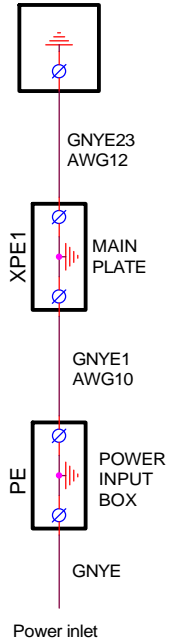

COLOR CODE:  
 -----  
 BK = black  
 BN = brown  
 RD = red  
 OG = orange  
 YE = yellow  
 GN = green  
 BU = blue  
 VT = violet  
 GY = grey  
 WH = white  
 PK = pink  
 BE = beige  
 RO = rose  
 GNYE = yellow-green

REV F: TKO (2009/04/02)  
 - see changes on page 4.

REV A: OH (2006/10/08)  
 REV B: OH (2007/01/09)  
 - see changes on other pages  
 REV C: OH (2007/05/03)  
 - XPE31,32 and GNYE19,20 added  
 - XPE33,34 and GNYE21 added  
 REV D: OH (2007/07/27)  
 - PE, XPE35 and GNYE22 added  
 - XPE26 removed, GNYE16 reconnected

STRUERS A/S  
 Pederstrupvej 84  
 DK-2750 Ballerup  
 Denmark

**ABRAPOL-20, CIRCUIT DIAGRAM  
 EARTH CONNECTIONS**

REV E: OHO (2008/11/20) - Z1, GNYE23 added	Size A3	CAGE Code	DWG NO <b>15883120</b>	Rev F
Friday, April 17, 2009	Scale	OH	Sheet 3 of 5	

5

4

3

2

1

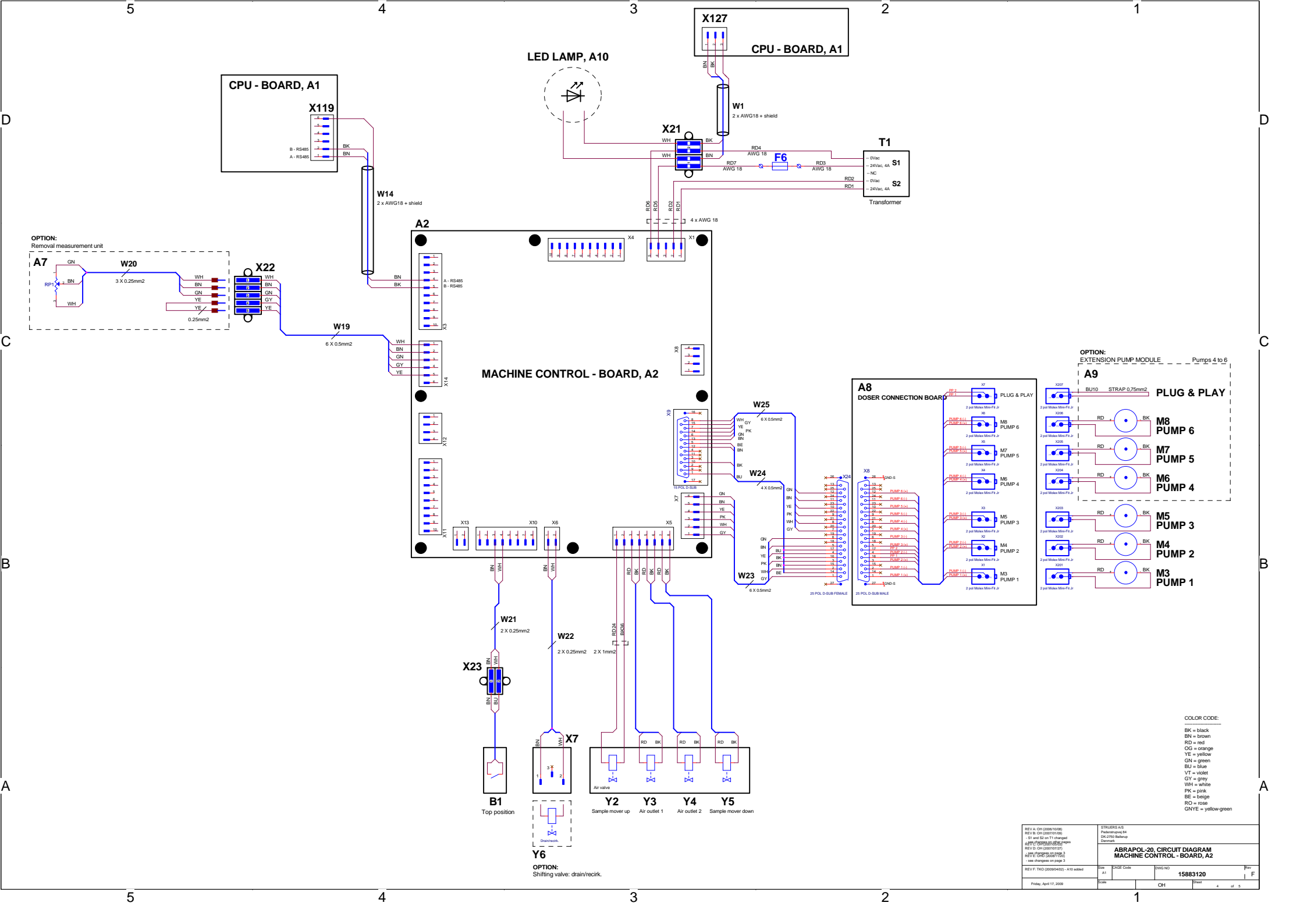

**CPU - BOARD, A1**



B - RS485  
A - RS485

**CPU - BOARD, A1**



WH  
BN  
BK

**T1**

S1  
S2  
Transformer

**MACHINE CONTROL - BOARD, A2**

**OPTION:**  
Removal measurement unit

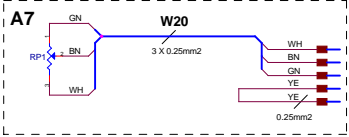

**OPTION:**  
EXTENSION PUMP MODULE - Pumps 4 to 6

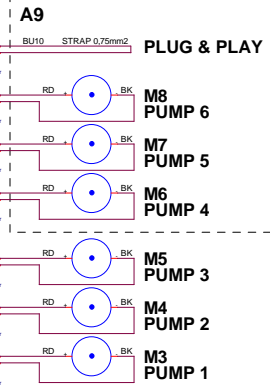

**A8 DOSER CONNECTION BOARD**

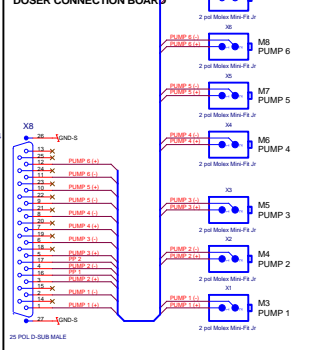

**COLOR CODE:**

- BK = black
- BN = brown
- RD = red
- OG = orange
- YE = yellow
- GN = green
- BU = blue
- VT = violet
- GY = grey
- WH = white
- PK = pink
- BE = beige
- RD = rose
- GNYE = yellow-green

REV A: GH (2009/10/30) REV B: GH (2007/01/03) REV C: GH (2007/01/03) REV D: GH (2007/01/03) REV E: GH (2007/01/03) REV F: GH (2007/01/03) * see changes on page 3	STRUISERS AS Postboksruimte 84 DK-2700 Bellingrup Denmark	<b>ABRAPOL-20, CIRCUIT DIAGRAM MACHINE CONTROL - BOARD, A2</b>	
REV F: TRC (2009/04/02) - A10 added	Scale	Sheet	15883120
Friday, April 17, 2009			

**A4**  
Frequency Inverter - 3kW, safety class 3  
(Safe standstill part only)

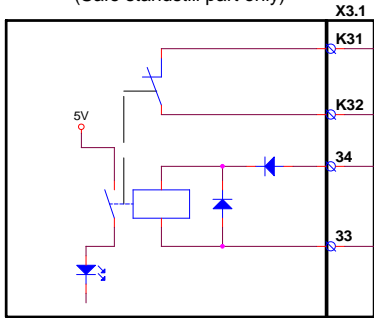

Inverter for Disc motor

**A3**  
Frequency Inverter - 3kW, safety class 3  
(Safe standstill part only)

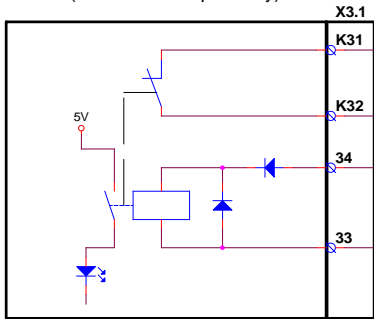

Inverter for Sample mover motor

**CPU - BOARD, A1**

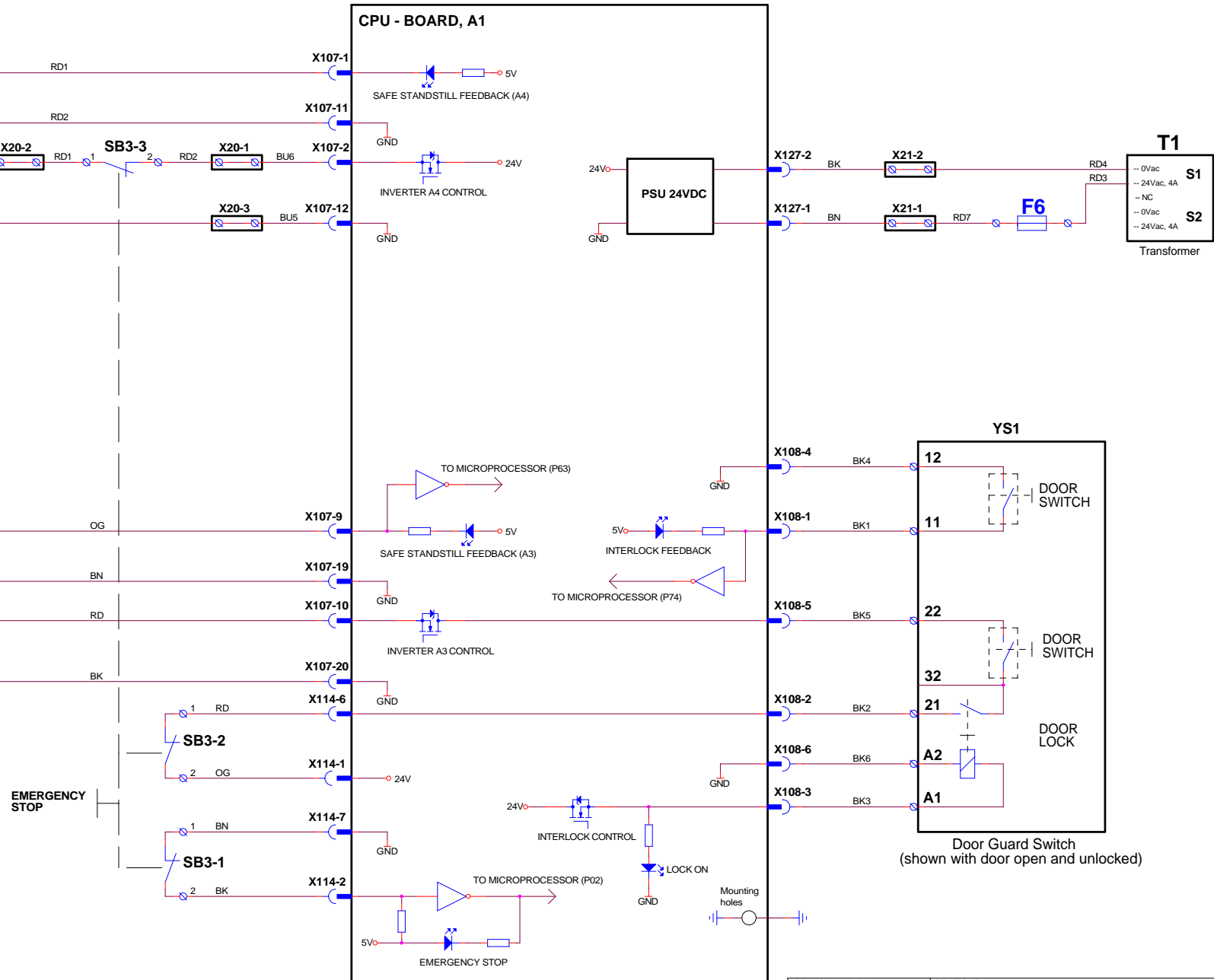

REV A: OH (2006/10/08)	STRUERS A/S		
REV B: OH (2007/01/09)	Pedestruvej 64		
- S1 and S2 on T1 changed	DK-2750 Ballerup		
- see changes on other pages	Denmark		
- cable for YS1 changed	<b>ABRAPOL-20, CIRCUIT DIAGRAM SAFETY RELATED CIRCUIT</b>		
REV C: OH (2007/05/03)			
REV D: OH (2007/03/27)			
- see changes on page 3			
REV E: OH (2008/11/20)			
- see changes on page 3	Size A2	CAGE Code	DWG NO <b>15883120</b>
REV F: TKO (2009/04/02)	Scale	OH	Sheet 5 of 5
- see changes on page 4	Friday, April 17, 2009		Rev F

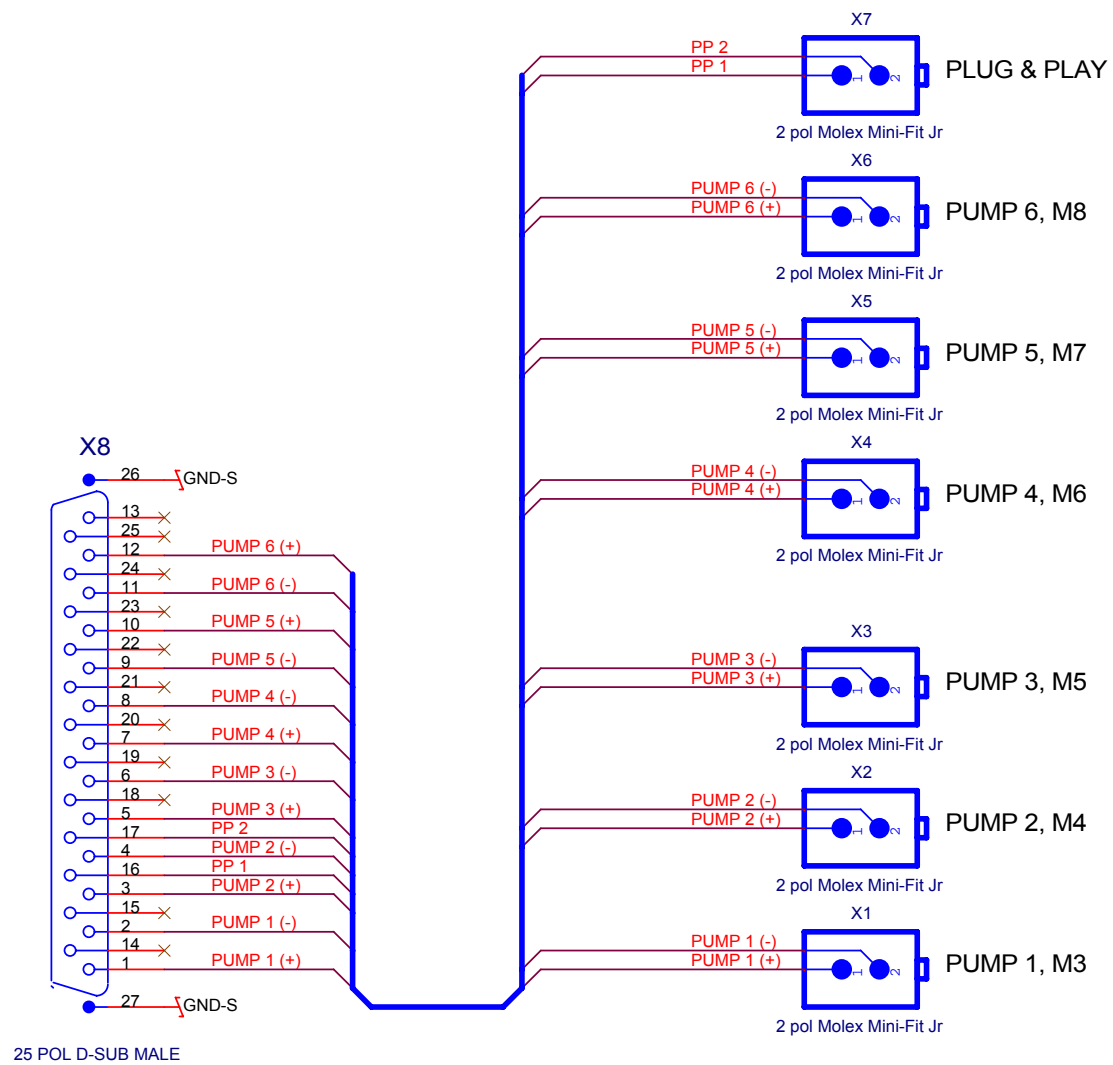

25 POL D-SUB MALE

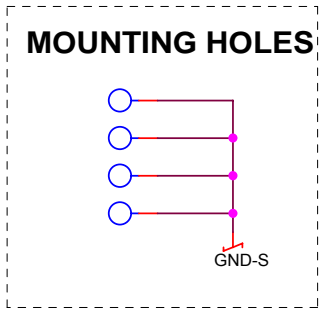

REV A: OH (2006/11/09)		STRUERS A/S PEDERSTRUPVEJ 84 DK-2750 BALLERUP DENMARK PHONE: +45 44 600 800	
<b>DOSER CONNECTION BOARD</b>			
Size A4	CAGE Code <Cage Code>	DWNG NO <b>15883200</b>	Rev <b>A</b>
Monday, December 11, 2006	Scale	OH	Sheet 1 of 1

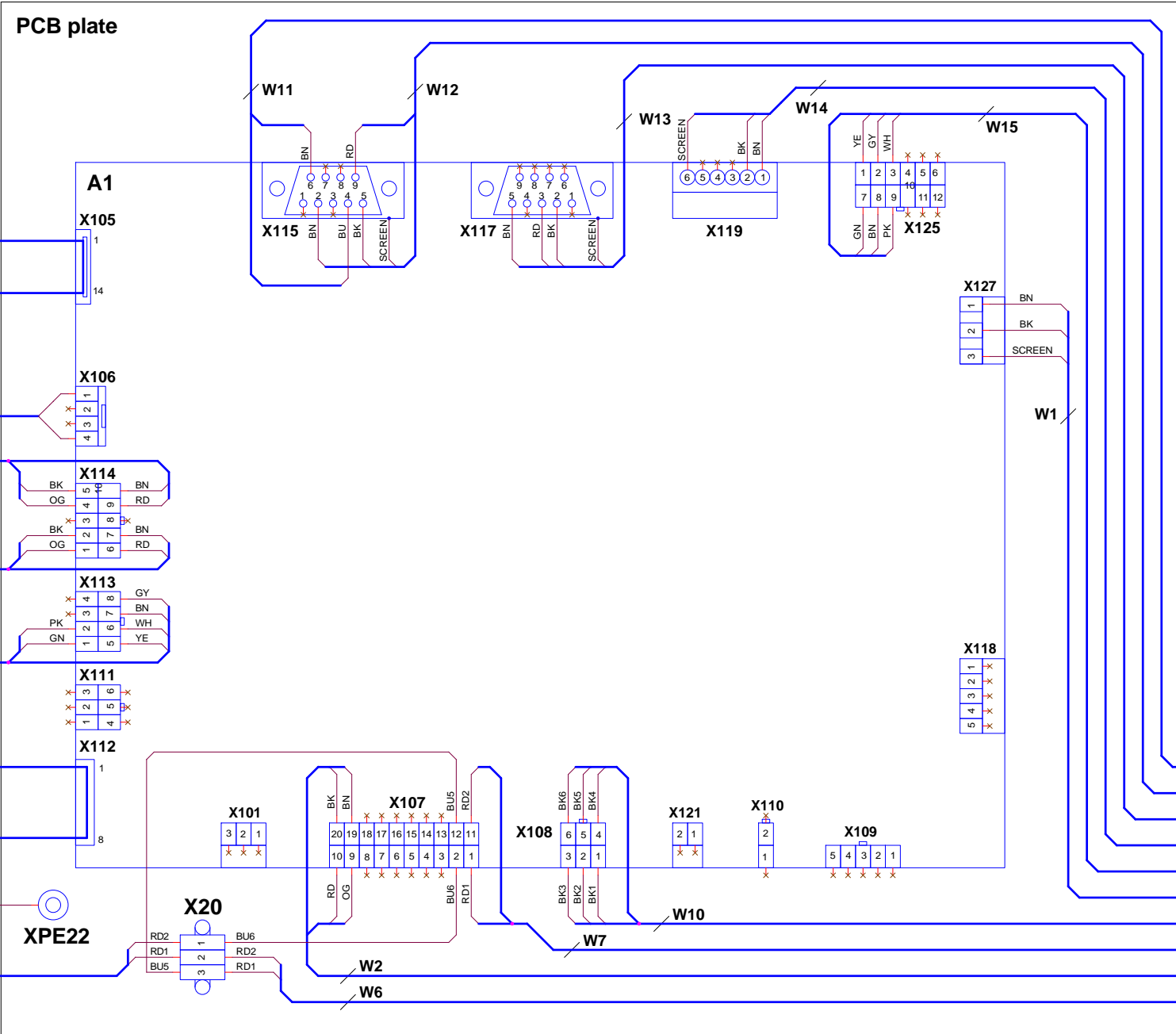

- COLOR CODE:
- BK = black
  - BN = brown
  - RD = red
  - OG = orange
  - YE = yellow
  - GN = green
  - BU = blue
  - VT = violet
  - GY = grey
  - WH = white
  - PK = pink
  - BE = beige
  - RO = rose
  - GNYE = yellow-green

A1:X105 to A5 (page 2)

A1:X106 to A5 (page 2)

A1:X114 to SB1, SB2 (page 2)

A1:X114 to SB3-1, SB3-2 (page 2)

A1:X113 to BR1 (page 2)

A1:X112 to A6 (page 2)

XPE22 to XPE21 (page 2) GNYE13

X20 to SB3-3 (page 2)

W11 A1:X115 to X116 (page 6)

W12 A1:X115 to A4:X3 (page 7)

W13 A1:X117 to X120 (page 6)

W14 A1:X119 to A2:X3 (page 3)

W15 A1:X125 to Y1 (page 6)

W1 A1:X127 to X21 (page 3)

W10 A1:X108 to YS1 (page 6)

W7 A1:X107 to A4:X3.1 (page 7)

W2 A1:X107 to A3:X3.1 (page 4)

W6 X20 to A4:X3.1 (page 7)

REV A: OH (2007/05/02)	STRUERS A/S Pederstrupvej 84 DK-2750 Ballerup Denmark		
REV B: OH (2007/07/27)	ABRAPOL-20, WIRING DIAGRAM PCB plate		
REV C: AKR (2007/09/19)	Size A2	CAGE Code	DWG NO 15883450
REV D: CHD (2008/12/03)	Scale	OHO	Sheet 1 of 10
REV E: TKO (2009/04/02)	Thursday, April 02, 2009		



# Plate for top PCB

**COLOR CODE:**  
 BK = black  
 BN = brown  
 RD = red  
 OG = orange  
 YE = yellow  
 GN = green  
 BU = blue  
 VT = violet  
 GY = grey  
 WH = white  
 PK = pink  
 BE = beige  
 RO = rose  
 GNYE = yellow-green

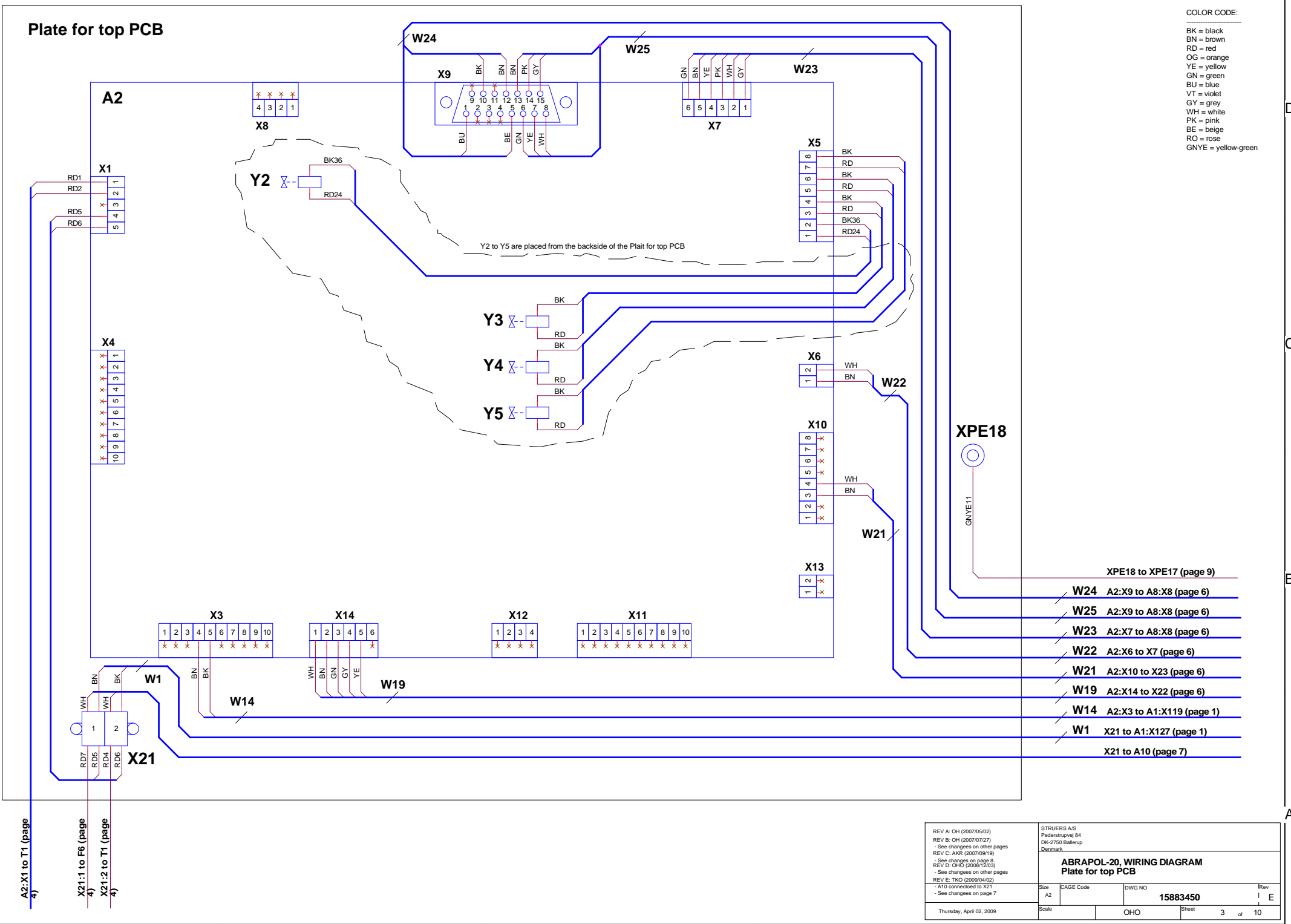

Y2 to Y5 are placed from the backside of the Plat for top PCB

- XPE18 to XPE17 (page 9)
- W24 A2:X9 to A8:X8 (page 6)
- W25 A2:X9 to A8:X8 (page 6)
- W23 A2:X7 to A8:X8 (page 6)
- W22 A2:X6 to X7 (page 6)
- W21 A2:X10 to X23 (page 6)
- W19 A2:X14 to X22 (page 6)
- W14 A2:X3 to A1:X119 (page 1)
- W1 X21 to A1:X127 (page 1)
- X21 to A10 (page 7)

A2:X1 to T1 (page 4)  
 X21:1 to F6 (page 4)  
 X21:2 to T1 (page 4)

REV A: OH (2007/05/02) REV B: OH (2007/07/27) - See changes on other pages REV C: AKR (2007/09/19) - See changes on page 8. REV D: CHS (2008/12/03) - See changes on other pages REV E: TKO (2009/04/02)	STRUERS A/S Pederstrupvej 84 DK-2750 Ballerup Denmark
<b>ABRAPOL-20, WIRING DIAGRAM Plate for top PCB</b>	
Size A2	CAGE Code DWG NO 15883450
Scale	Sheet 3 of 10
Thursday, April 02, 2009	OHO



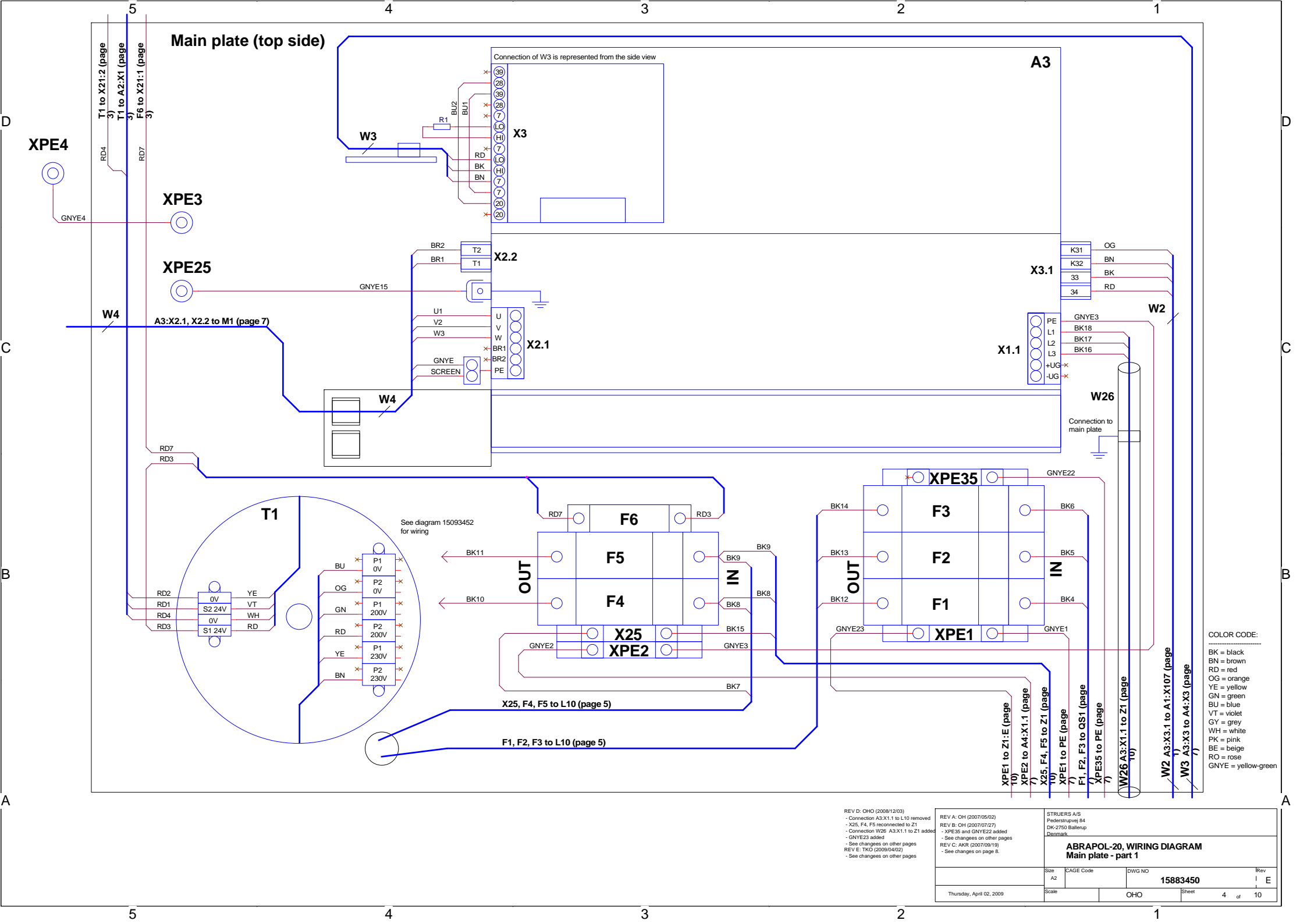

Main plate (bottom side)

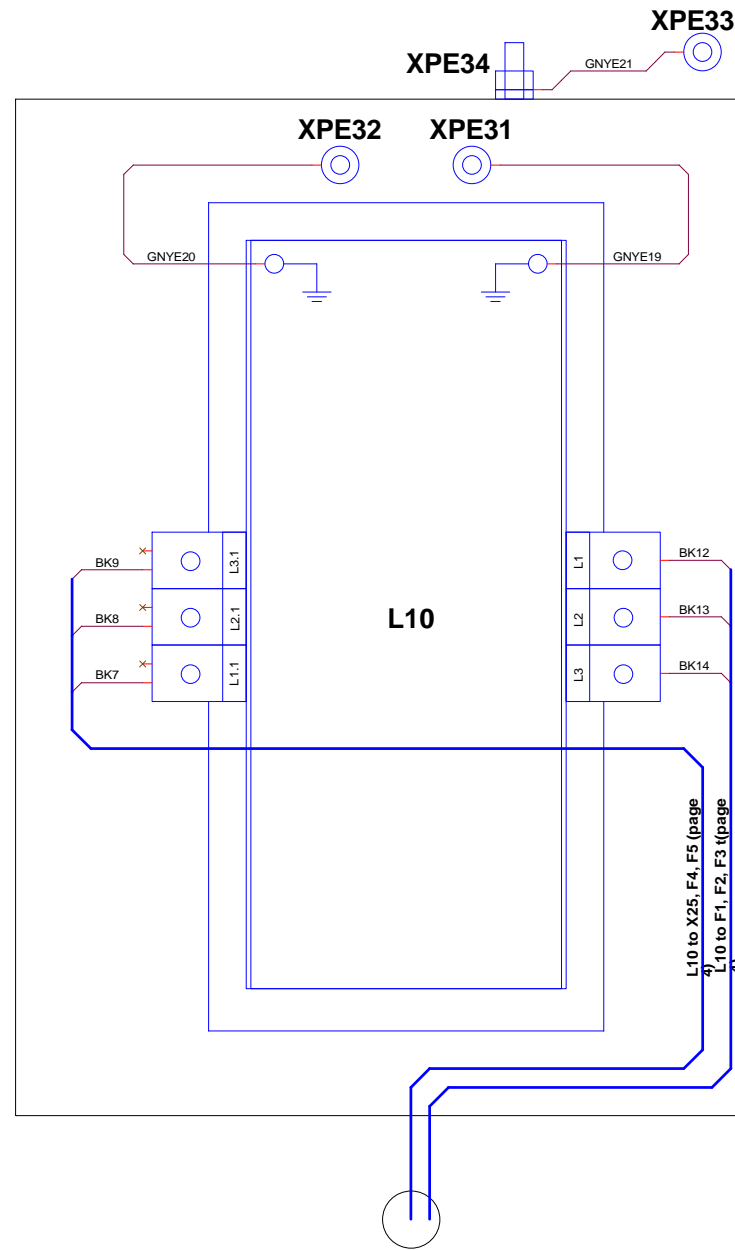

COLOR CODE:  
 BK = black  
 BN = brown  
 RD = red  
 OG = orange  
 YE = yellow  
 GN = green  
 BU = blue  
 VT = violet  
 GY = grey  
 WH = white  
 PK = pink  
 BE = beige  
 RO = rose  
 GNYE = yellow-green

REV A: OH (2007/05/02) REV B: OH (2007/07/27) - See changes on other pages REV C: AKR (2007/09/19) - See changes on page 3. REV D: CHO (2008/12/03) - Connection L10 to A3.X1.1 removed - See changes on other pages	STRUERS A/S Pederstrupvej 84 DK-2750 Ballerup Denmark	<b>ABRAPOL-20, WIRING DIAGRAM Main plate - part 2</b>		
REV E: TKO (2009/04/02) - See changes on other pages	Size A2	CAGE Code	DWG NO <b>15883450</b>	Rev I E
Thursday, April 02, 2009	Scale	OHO	Sheet 5 of 10	

### Connection on the base frame

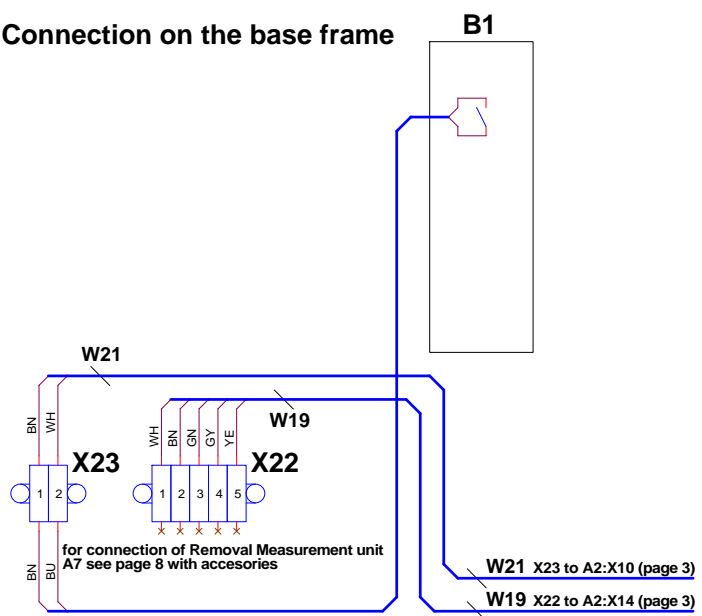

### Connection of Doser connection board A8

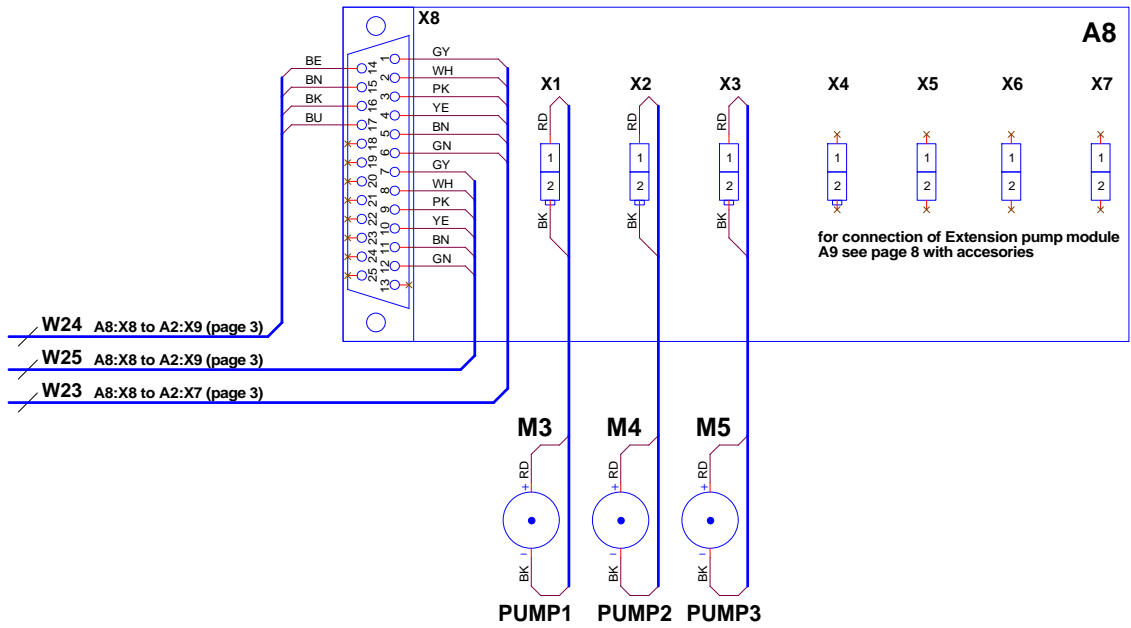

### Connection of Tap water valve Y1

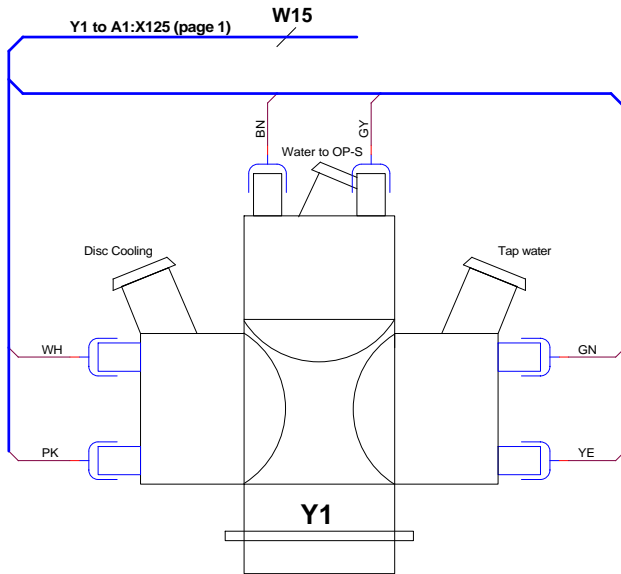

### Connection of X7 (for Shifting valve Y6)

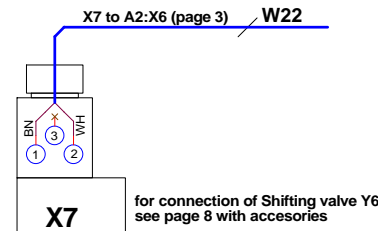

### Connection of Door Guard Switch YS1

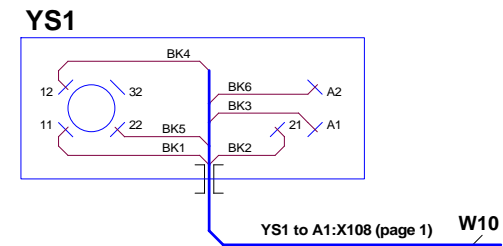

### Connection of Connector for service X120

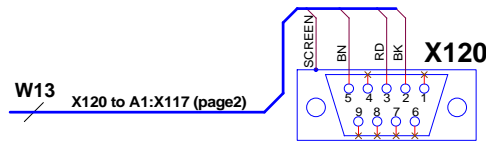

### Connection of Connector for Cooli X116

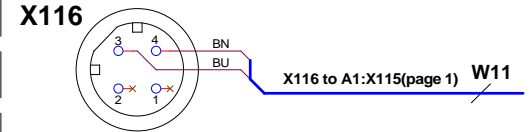

- COLOR CODE:**
- BK = black
  - BN = brown
  - RD = red
  - OG = orange
  - YE = yellow
  - GN = green
  - BU = blue
  - VT = violet
  - GY = grey
  - WH = white
  - PK = pink
  - BE = beige
  - RO = rose
  - GNYE = yellow-green

REV A: OH (2007/05/02) REV B: OH (2007/07/27) - See changes on other pages REV C: AKR (2007/09/19) - See changes on page 8. REV D: CHO (2008/12/03) - See changes on other pages	STRUERS A/S Pederstrupvej 84 DK-2750 Ballerup Denmark			
<b>ABRAPOL-20, WIRING DIAGRAM Various connections - part 1</b>				
REV E: TKO (2009/04/02) - See changes on other pages	Size A2	CAGE Code	DWG NO <b>15883450</b>	IRev 1 E
Friday, April 17, 2009	Scale	OHO	Sheet 6 of 10	



### Connection of Removal measurement unit A7

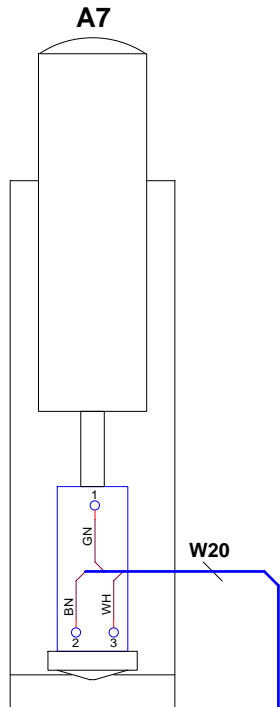

for other connection of X22 see page 6

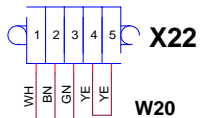

### Connection of Extension pump module A9

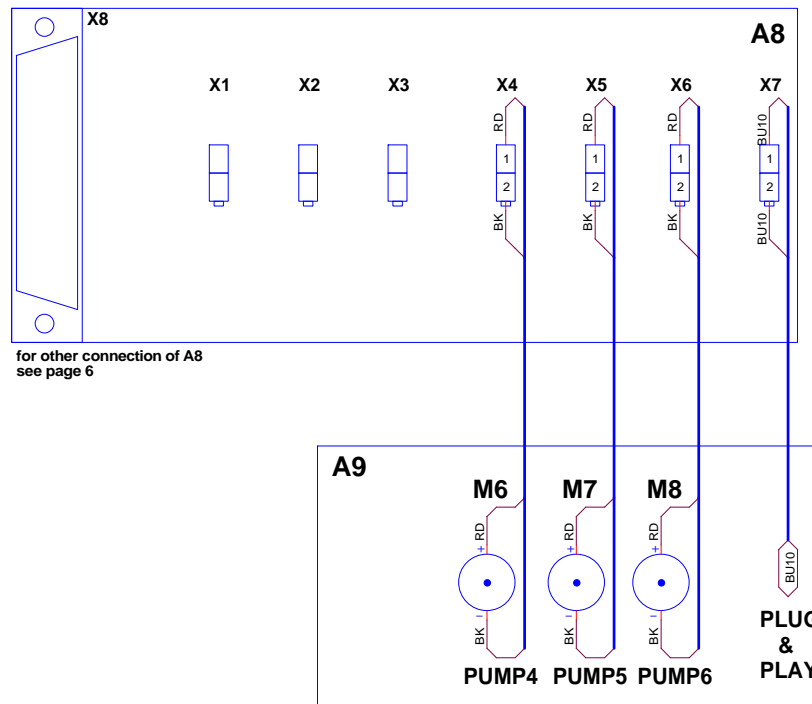

for other connection of A8 see page 6

### Connection of Shifting valve Y6

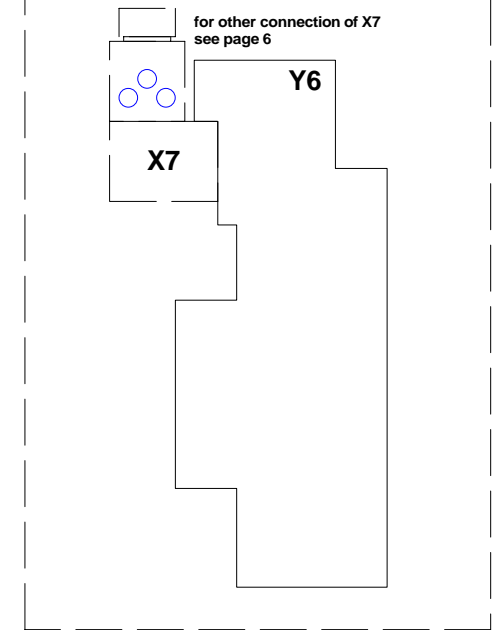

COLOR CODE:  
 BK = black  
 BN = brown  
 RD = red  
 OG = orange  
 YE = yellow  
 GN = green  
 BU = blue  
 VT = violet  
 GY = grey  
 WH = white  
 PK = pink  
 BE = beige  
 RO = rose  
 GNYE = yellow-green

REV A: OH (2007/05/02) REV B: OH (2007/07/27) - See changes on other pages REV C: AKR (2007/09/19) - RD and BK at X7 changed to BU10. REV D: OHO (2008/12/03) - See changes on other pages	STRUERS A/S Paderstrupvej 84 DK-2750 Ballerup Denmark
<b>ABRAPOL-20, WIRING DIAGRAM                  Accessories</b>	
REV E: TKO (2009/04/02) - See changes on other pages	Size A2 CAGE Code DWG NO <b>15883450</b> Rev I E
Thursday, April 02, 2009	Scale OHO Sheet 8 of 10

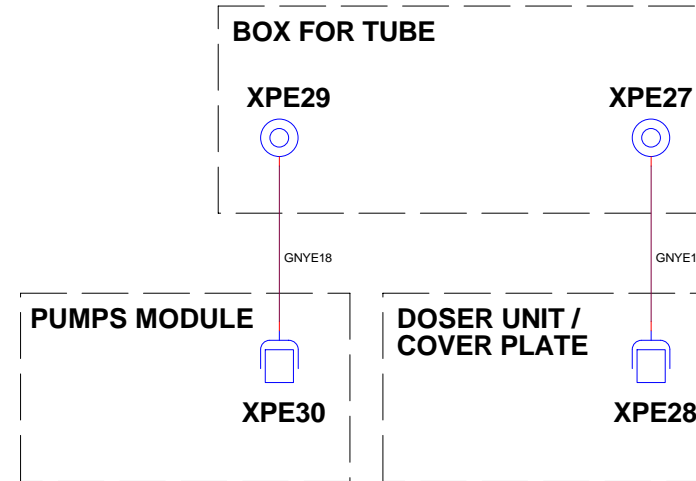
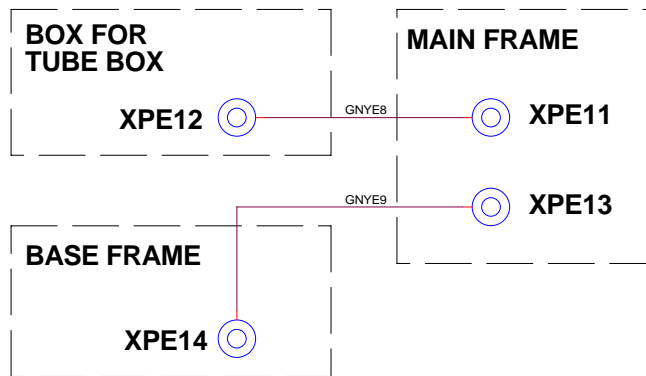
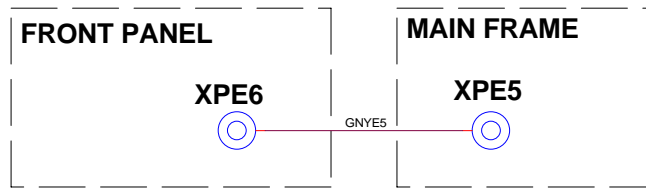
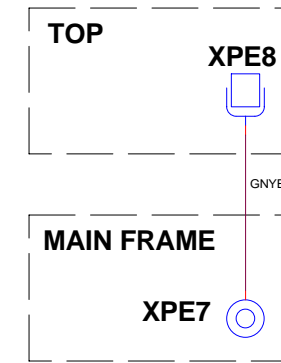
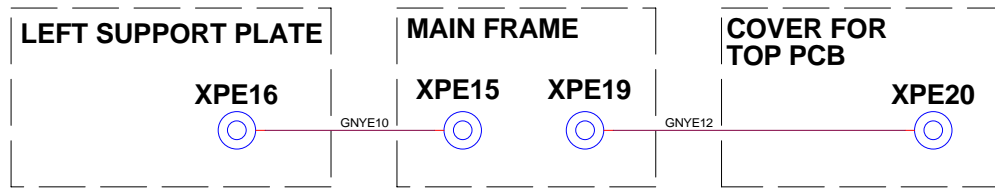

**COLOR CODE:**

- BK = black
- BN = brown
- RD = red
- OG = orange
- YE = yellow
- GN = green
- BU = blue
- VT = violet
- GY = grey
- WH = white
- PK = pink
- BE = beige
- RO = rose
- GNYE = yellow-green

REV B: OH (2007/07/27) - New page 9 created - See changes on other pages REV C: AKR(2007/09/19) - See changes on page 5 REV D: CHC (2008/10/03) - See changes on other pages REV E: THG (2009/04/02) - See changes on other pages	STRUERS A/S Pedersbuenvej 84 DK-2750 Ballerup Denmark		
<b>ABRAPOL-20, WIRING DIAGRAM</b> <b>Protective bonding circuit (the rest)</b>			
Size A2	CAGE Code	DWG NO	Rev
		<b>15883450</b>	<b>1 E</b>
Thursday, April 02, 2009	Scale	OHO	Sheet 9 of 10

### Connection of EMC filter Z1

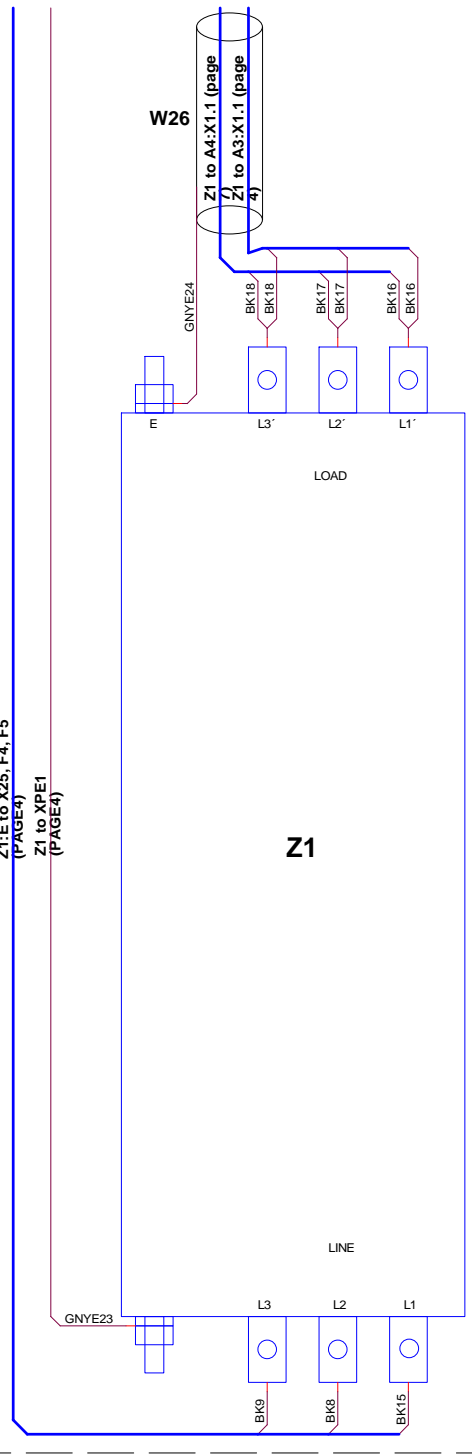

### Connection box on the sample mover motor M1

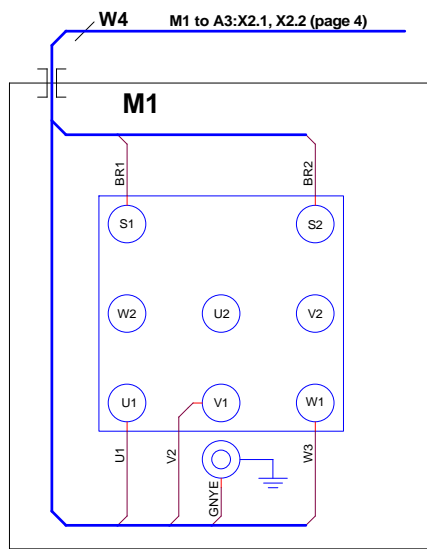

Motor coupling for  
3 x 380V-480V 50/60Hz  
STAR

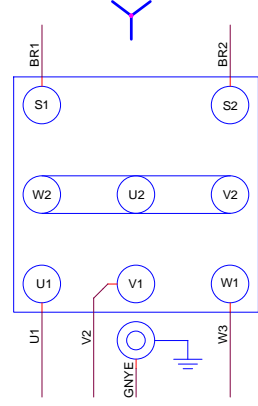

Motor coupling for  
3 x 200V-240V 50/60Hz  
DELTA

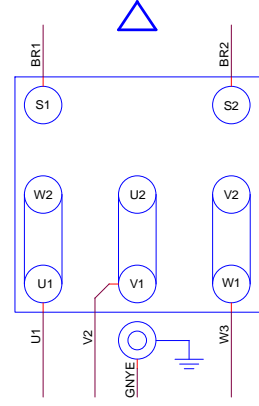

### Connection box on the disc motor M2

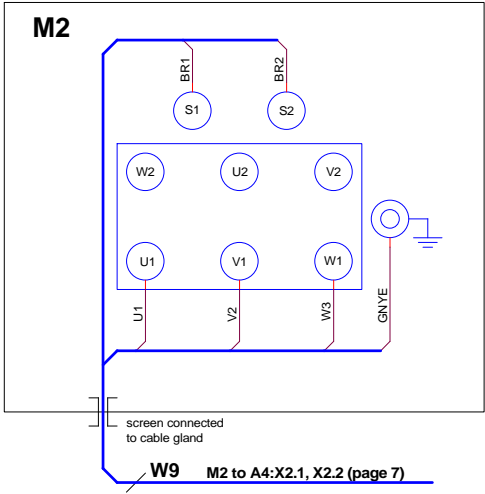

Motor coupling for  
3 x 380V-480V 50/60Hz  
STAR

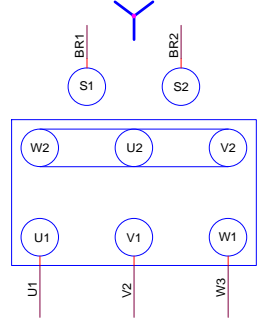

Motor coupling for  
3 x 200V-240V 50/60Hz  
DELTA

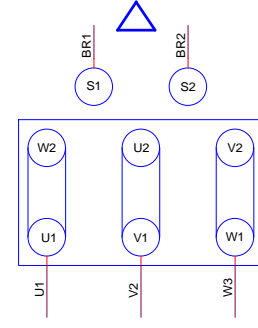

- COLOR CODE:
- BK = black
  - BN = brown
  - RD = red
  - OG = orange
  - GN = green
  - YE = yellow
  - BU = blue
  - VT = violet
  - GY = grey
  - WH = white
  - PK = pink
  - BE = beige
  - RO = rose
  - GNYE = yellow-green

Z1,E to Y25, F4, F5  
(PAGE4)  
Z1 to XPE1  
(PAGE4)

REV D: OHO (2008/12/03) - New page created - Connection of M1, M2 updated - See changes on other pages REV E: TKO (2009/04/02) - See changes on other pages		STRUERS A/S Pederstrupvej 84 DK-2750 Ballerup Denmark	
<b>ABRAPOL-20, WIRING DIAGRAM Connection of Z1, M1, M2</b>			
Size A2	CAGE Code	DWG NO <b>15883450</b>	Rev I E
Thursday, April 02, 2009	Scale	OHO	Sheet 10 of 10

**Overview, variant parts in Abrapol-20.**

Country nom. Voltage /frequency	Gear Motor M1 nameplate	Freq. converter A3	Motor M2 nameplate	Freq. Converter A4	Transformer T1		Fuses F1,F2,F3	Fuses F4, F5	Fuse F6	Ordering number
					Type	Connections				
Japan 3x200V / 50Hz <b>CSA-norm.</b>  Japan + USA + Canada 3x200-210V / 60 Hz	Item nr.: 2MD10000 Voltage: 3 x 230 V Power: 0,55 kW  Connection: DELTA	Item nr.: 2PU82303 Voltage: 3 x 230 V Power: 3 kW	Item nr.: 2ME60000 Voltage: 3 x 230V Power: 2,2 kW  Connection: DELTA	Item nr.: 2PU82303 Voltage: 3 x 230 V Power: 3 kW		Connection: 200 ÷ 210 V  I <sub>max</sub> = 0,65 A  Item No.: 2x 2XL30402	20 AT (Class-CC) 2FC11200	2 AT (Class-CC) 2FC11020		05886129  3x200- 210V/50 or 60Hz  Mains Fuses Max 50 AT
Norway, France, Belgium 3x220-230V / 50 Hz  USA, Mexico, Brasil, S.Korea. 3x220-240V / 60 Hz										Item No.: 2MT72034  Ulveco No.: AA-72034
Europe 3x380-415V / 50Hz  South America 3x380-415V / 60Hz	Item nr.: 2MD10000 Voltage: 3 x 400 V Power: 0,55 kW  Connection: STAR	Item nr.: 2PU84303 Voltage: 3 x 400 V Power: 3 kW	Item nr.: 2ME60000 Voltage: 3 x 400V Power: 2,2 kW  Connection: STAR	Item nr.: 2PU84303 Voltage: 3 x 400 V Power: 3 kW	See diagram: 15093452	Connection: 380 ÷ 415 V  I <sub>max</sub> = 0,33 A  Item No.: 1x 2XL30402	16 AT (aM) 2FC10160	1 AT (aM) 2FC10010		05886146  3x380-415V /50 or 60Hz  Mains Fuses Max 50 AT
<b>CSA-norm.</b> USA + Canada 3x460-480V / 60 Hz										Connection: 460 ÷ 480 V  I <sub>max</sub> = 0,33 A  Item No.: 1x 2XL30402







Pederstrupvej 84  
DK-2750 Ballerup  
Denmark